

**STATE OF MINNESOTA
BOARD OF ARCHITECTURE, ENGINEERING, LAND SURVEYING,
LANDSCAPE ARCHITECTURE, GEOSCIENCE AND INTERIOR DESIGN**

In the Matter of
Jan H. Zicha, unlicensed

**CEASE AND DESIST ORDER
AND
NOTICE OF RIGHT TO HEARING**

Board File No: 2004-0008

TO: Jan H. Zicha
8629 Leslie Avenue
Lanham, MD 20706

ALLEGATIONS

The Complaint Committee of the Board of Architecture, Engineering, Land Surveying, Landscape Architecture, Geoscience and Interior Design ("Board") alleges as follows:

1. A complaint concerning Jan H. Zicha ("Respondent") has been received and reviewed by the Board's Complaint Committee.
2. Respondent is not currently and never has been licensed by the Board as a professional engineer in the State of Minnesota.
3. Respondent is licensed as a professional engineer in the State of Maryland.
4. Respondent applied to become licensed in Minnesota as a professional engineer through comity in September 2002.
5. The Board notified Respondent that his comity application was incomplete. A true and correct copy of the email notifying Respondent that his comity application was incomplete is attached hereto as Exhibit A.
6. Respondent has since failed to complete his application for licensure.
7. Respondent reviewed the following documents for the Hiawatha Corridor Light Rail Project that is located in Minnesota:

- Production Testing and Quality Control of the Reinforced Concrete Blocks of the Low Vibration Track (LVT) System
- Production Testing and Quality Control of the Resilient Block Pads of the Low Vibration Track (LVT) System
- Production Testing and Quality Control of the Rubber Boots of the Low Vibration Track (LVT) System
- LVT Supports Design Document for Hiawatha LRT for the Hiawatha Corridor Light Rail Project.

True and correct copies of the documents are attached hereto as Exhibit B, C, D, and E.

8. Respondent stamped these documents using his Maryland stamp. He also typed on them, "I have applied for the registration in Minnesota and the application is pending." He signed and dated the documents January 16, 2003. True and correct copies of the documents are attached hereto as Exhibit B, C, D, and E.

9. Respondent reviewed shop drawings for this Minnesota Hiawatha Corridor Light Rail project. He used his Maryland stamp, and typed on the drawings, "I have applied for the registration in Minnesota and the application is pending." He signed and dated these drawings January 16, 2003. True and correct copies of the shop drawings are attached hereto as Exhibit F.

10. In an email dated August 28, 2003, Respondent admits to stamping drawings for this project. Respondent states:

"I have stamped mentioned drawings in the past and returned them to my client Permanent Way Corporation. I do not know what action was taken on this project after that. All I can say is that the LVT track supplied by PWC is the best choice available on the world market. It requires virtually no maintenance and has at least ten time longer life expectancy than anything else of the kind, as we have already found on LVT

installation at twenty locations world-wide. Ther (sic) is no secret that not all of PWC's competitors like it. However, the proper place for improvement of their products is at the drafting board."

A true and correct copy of the email dated August 28, 2003 is attached hereto as Exhibit G.

11. The following order is in the public interest.

ORDER

NOW, THEREFORE, IT IS HEREBY ORDERED, pursuant to Minn. Stat. § 326.111, subd. 3 (2002), that Respondent **Jan H. Zicha** shall **CEASE AND DESIST** from holding himself out as a professional engineer in Minnesota, from practicing professional engineering in Minnesota, and from further violations of Minn. Stat. §§ 326.02 to 326.15 (2002) until such time as he becomes licensed as a professional engineer in the state of Minnesota.

IT IS FURTHER ORDERED THAT pursuant to Minn. Stat. § 326.111, subd. 6 (2002), Respondent shall pay a **CIVIL PENALTY** of ten thousand dollars (\$10,000.00) to the Board, within sixty (60) days after the date of the Board's approval of this cease and desist order. In accordance with Minn. Stat. § 16D.17, Subd. 2 (2002), in the event this Order becomes final, the Board may file and enforce the civil penalty as a judgment without further notice or additional proceedings.

NOTICE OF RIGHT TO HEARING

Pursuant to Minn. Stat. § 326.111, subd. 3 (2002), Respondent may request a hearing in this matter. Such request must be in writing and served upon the Board within thirty days after service of this Order, whereupon a hearing will be held within thirty days after receipt of the request unless Respondent and the Complaint Committee agree that the hearing be scheduled after the thirty-day period. In accordance with Minn. Stat. § 326.111, subd. 3 (2002), if no hearing is requested by Respondent within

thirty days of service of this Order, this Order will become final and will remain in effect until it is modified or vacated by the Board. In accordance with Minn. Stat. § 16D.17, Subd. 2 (2002), in the event this Order becomes final, the Board may file and enforce the civil penalty as a judgment without further notice or additional proceedings.

In the event a hearing is scheduled in this matter, it will be held before an administrative law judge of the Office of Administrative Hearings for the State of Minnesota, 100 Washington Square, Suite 1700, Minneapolis, Minnesota 55401-2138, Telephone: (612) 341-7610. All parties have the right to represent themselves or be represented throughout the proceedings herein by legal counsel or a person of their choice if not otherwise prohibited as the unauthorized practice of law. The hearing will be conducted pursuant to the contested case procedures as prescribed in Minn. Stat. §§ 14.57 to 14.69 (2002), as amended, and the Rules of the Office of Administrative Hearings, Minn. Rules Ch. 1400.5010 to 1400.8401 (2003). Failure to attend the hearing in this matter may result in the allegations of this Order being taken as true and deemed proved without further evidence, the proceeding being determined against the party failing to attend. Questions concerning this Order may be directed to Assistant Attorney General Michele Owen, 1800 NCL Tower, 445 Minnesota Street, St. Paul, Minnesota 55101, Telephone: (651) 297-3995.

Copies of the above-cited statutes and procedural rules are available on-line at www.revisor.leg.state.mn.us or may be purchased from the Department of Administration, Public Documents Division, 117 University Avenue, St. Paul, Minnesota 55155, telephone: (651) 297-3000.

IF YOU NEED A REASONABLE ACCOMMODATION for a disability in order to participate in the hearing process, such an accommodation can be made available upon advance request so that the hearing is accessible. Examples of reasonable accommodations include wheelchair accessibility, an interpreter, or Braille or large-print materials. If any party requires an interpreter, including a foreign language interpreter, the Board office must be promptly notified. To arrange an accommodation or an

Interpreter, you may contact Doreen Frost, Executive Director of the Board, Suite 160, 85 East Seventh Place, St. Paul, Minnesota 55101, or you may call: Voice (651) 296-2388 or TDD (651) 297-5353.

Dated: 5/14/04, 2004

STATE OF MINNESOTA
BOARD OF ARCHITECTURE,
ENGINEERING, LAND SURVEYING,
LANDSCAPE ARCHITECTURE,
GEOSCIENCE AND INTERIOR DESIGN

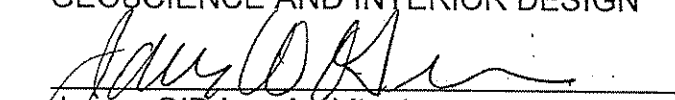

James O'Brien, Architect
Chair

Shari Telega

To: janzicha@cs.com
Subject: Application for Licensure



RefLtrInstructions.dPeVerifyReqEmail.dMEMO.ECEI.EVAL.
oc oc doc

Dear Jan Zicha:

In reference to your application for licensure as a Professional Engineer by Comity to the Minnesota Board of Architecture, Engineering, Land Surveying, Landscape Architecture, Geoscience and Interior Design (Board), the following documents have not yet been received:

1. Five reference letters (completed according to the "Instructions to Applicants Regarding the Submission of Reference Form" - included in the application packet)
2. Fundamentals and Professional Exam Verifications
3. Official Transcripts

Four of the reference letters to accompany your application for licensure as a Professional Engineer by Comity in Minnesota have been received and are incorrectly completed. Please review the attached "Instructions to Applicants Regarding the Submission of Reference Forms" (also included in the application packet). On the second page, you are to include the same experience record as is furnished in item number 22 of the G-4 application. Each reference is to initial statements that he/she can substantiate.

The Board has not yet received verification of your exams. If these verifications are in process, thank you. If you need another verification form, one is attached.

Finally, we have not yet received Official Transcripts. In your letter dated September 23, 2002, you state that you graduated from the University of Zilina in Europe. This University is not ABET accredited and so must be evaluated. If it has not yet been, I have also attached a memo concerning evaluation of foreign education for your use.

If you intend to pursue licensure in Minnesota, please be certain that the above-mentioned documents are complete and submit them to the Board at the address above. Upon receipt of the requested information, further consideration will be given to your application.

Respectfully,
Shari Telega
PE Licensing Coordinator
MN Board of AELSLAGID

EXHIBIT A

Doc. No.:
Approval: . . .
Orig. Date: . . .
Rev. Level:
Rev. Approval:
Rev. Date:

STR 030.A67
BS
24 April, 2001
A

Production testing shall be performed at the manufacturer's laboratory or, if such laboratory is not equipped to perform one or more of the tests specified herein, at a qualified outside laboratory.

If all the control and test results specified herein are satisfactory, the daily batch defined as all the concrete blocks produced during one day shall be accepted. Any control or test failure shall cause the daily batch to be rejected.

1 Concrete Control Tests

1.1 Procedure

The vibration of the casting machine or a vibrating table shall be used to compact the concrete in the moulds. The moulds shall be moist cured from the time of moulding until the moment of test. The curing of the concrete moulds shall be performed in accordance with ASTM C192 or other equivalent specification.

The flexural strength test shall be executed in accordance with ASTM C 78 (beams) or other equivalent specification.

The manufacturer may also, at its option, produce concrete blocks omitting the steel reinforcements and perform the concrete control tests on cores taken from these blocks. In case of discrepancies between the results on cylinders and on cores, the results on cores shall prevail.

1.2 Acceptance Criteria

The minimum strength requirements shall be as follows:

- Compressive strength $F_c = 7000$ psi
- Flexural strength $F_t = 600$ psi

1.3 Frequency

The manufacturer shall produce 4 test specimens (2 cylinders and 2 beams) per production week.

2 test specimens shall be tested at 7 days, one for compressive strength and one for flexural strength.

2 test specimens shall be tested at 28 days, one for compressive strength and one for flexural strength.

If the strength requirements are met at 7 days, then the corresponding 28 day tests shall be waived.

If the strength requirements are met neither at 7 nor at 28 days, the daily batches corresponding to the production week for which the requirements were not met shall be rejected unless the requirements are met on cores as provided in

Doc. No.:
Approval:
Orig. Date:
Rev. Level:
Rev. Approval:
Rev. Date:

STR 030.A67
BS
24 April, 2001
A

paragraph 1.1.

2 Dimensional Control

2.1 Procedure

The dimensional tolerances shall conform to the approved shop drawings when measured with instruments or go/no go gauges as stipulated in the approved technical specifications.

2.2 Frequency

Two concrete blocks per daily batch shall be subjected to dimensional control.

3 Aspect Control

3.1 Procedure

The concrete block shall be visually inspected for cracks, structural defects and surface finish.

3.2 Acceptance Criteria

The concrete block shall not present cracks, structural defects, or surface finish defects incompatible with the satisfactory long term performance of the system.

3.3 Frequency

All concrete blocks shall be subjected to the aspect control.

4 Fastening Shoulder Tests

4.1 Procedure

This test shall not be performed before 28 days or a 7000 psi concrete compressive strength is achieved, whichever is sooner.

The rail fastenings shall be subjected to the pull-out and torque tests described in AREA (American Railway Engineering Association) chapter 10, paragraph 1.9.1.9.

4.2 Frequency

The pull out test shall be performed on one concrete block per daily batch.

The torque test shall be performed on one concrete block per daily batch.

Doc. No.:
Approval:
Orig. Date:
Rev. Level:
Rev. Approval:
Rev. Date:

STR 030.A67
B5
24 April, 2001
A

Hiawatha Corridor Light Rail Project

MNDOT Agreement No. 80356
Railworks Track Systems, Inc.

Production Testing and Quality
Control of the Reinforced Concrete Blocks
Of the Low Vibration Track (LVT) System Supplied by
The Permanent Way Corporation

Persons Transportation Group Inc.
Edwards and Kelcey, Inc. Joint Venture

- Accepted
- Accepted as Noted
- Rejected, Revise and Resubmit

Approval is only for general conformance with the design concept of the Project and the information given in the Contract Documents. Contractor is responsible for dimensions to be confirmed and correlated at the job site; information that pertains solely to the fabrication process or to the means & methods of construction; coordination of the work of all trades; and performing all work in a safe & satisfactory manner. This approval does not modify Contractor's duty to comply with the Contract Documents.

By: *David [Signature]* Date: *01-31-03*



Jan H. Kicha, P.E.
January 16, 2003

I have applied for the registration in
Minnesota and the application is pending.

EXHIBIT B

Doc. No.:	STR 030.A67
Approval:	BS
Orig. Date:	24 April, 2001
Rev. Level:	A
Rev. Approval:	
Rev. Date:	

Table of Contents

	Page Number
1. CONCRETE CONTROL TESTS	3
1.1 Procedure	3
1.2 Acceptance Criteria	3
1.3 Frequency	3
2. DIMENSIONAL CONTROL	4
2.1 Procedure	4
2.2 Frequency	4
3. ASPECT CONTROL	4
3.1 Procedure	4
3.2 Acceptance Criteria	4
3.3 Frequency	4
4. FASTENING SHOULDER TESTS	4
4.1 Procedure	4
4.2 Frequency	4
5. POSITIVE BENDING MOMENT TEST	5
5.1 Procedure	5
5.2 Acceptance Criteria	6
5.3 Frequency	6
6. FIGURE 1	7

Doc. No.:
Approval: :
Orig. Date:
Rev. Level:
Rev. Approval:
Rev. Date:

STR 030.A67
BS
24 April, 2001
A

5 Positive Bending Moment Test

This test shall not be performed before 28 days or a 7000 psi concrete compressive strength is achieved, whichever is sooner.

5.1 Procedure

The configuration for the positive bending moment test shall be as shown in figure 1.

The objective of this test shall be to record the load required to produce the first crack in the concrete block, and to evaluate the reinforcements' effectiveness in closing the cracks after the removal of the load.

Levels P1 and P2

The concrete block shall be positioned under the press actuator and subjected to an initial load of 20,000 lbs.

The loading of the concrete block shall be progressively increased by 4000 lbs. increments. After each increment, the load shall be maintained for a minimum of 1 minute while both side surfaces of the concrete block are examined for the presence of cracks.

- P1 shall be defined as the load required to generate the first crack.

After P1 has been reached, the concrete block shall be subjected to successive zero-to-peak loading cycles. The peak load of each cycle shall be increased by a 4000 lbs. increment.

In each cycle, the load shall be gradually increased from zero up to the peak load. The peak load shall be held for a minimum of 1 minute before being fully released.

Once the load has been released, the width of the cracks on the side surfaces of the unloaded concrete block shall be measured and recorded.

The crack widths shall be measured at the level corresponding to the theoretical position of the lower reinforcement's centroid. If it is not possible to measure a crack at this level due to chipping of the concrete or surface imperfections, measurements shall be taken equidistant and as close as possible above and below this level; the two values shall be averaged to obtain the width of the crack.

- P2 shall be defined as the peak load of the last cycle in which the widest crack on the concrete block is closed after the removal of the load. A crack whose width does not exceed 0.002 in. shall be considered to be closed.

Doc. No.:	STR 030.A67
Approval:	BS
Orig. Date:	24 April, 2001
Rev. Level:	A
Rev. Approval:	
Rev. Date:	

Levels P3 and P4

After reaching level P2, the incremental loading cycles shall be resumed.

- P3 shall be defined as the peak load of the last cycle in which the opening of the widest crack on the unloaded concrete block is not greater than 0.02 in.

After reaching level P3, the load shall be gradually increased until the ultimate failure of the rail concrete block.

- P4 shall be defined as the maximum load carried by the concrete block.

5.2 Acceptance Criteria

Specified values for P2 and P3 are:

$P2 \geq 40,000$ lbs., $P3 \geq 60,000$ lbs.

5.3 Frequency

The rail seat positive bending moment test shall be performed on one concrete block per daily batch.

Every concrete block subjected to this test shall be tested up to level P2.

Only every 10th concrete block subjected to this test shall be tested up to level P4.

Doc. No.:	STR 030.A67
Approval:	BS
Orig. Date:	24 April, 2001
Rev. Level:	A
Rev. Approval:	
Rev. Date:	

6 Figure 1

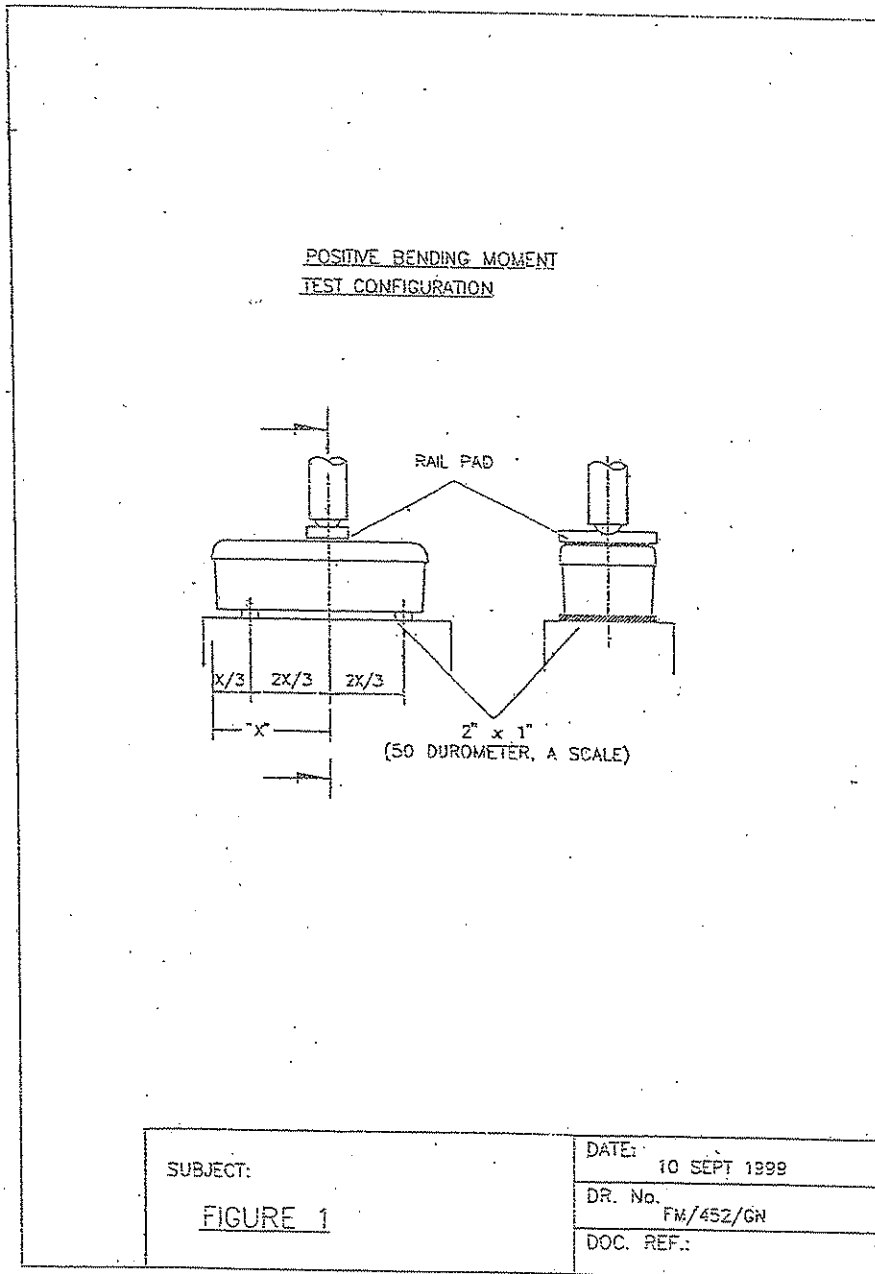

Doc. No.:	SBP 003.A67
Approval:	BS
Orig. Date:	24 April, 2001
Rev. Level:	A
Rev. Approval:	
Rev. Date:	

Hiawatha Corridor Light Rail Project
MNDOT Agreement No. 80356
Railworks Track Systems, Inc.

Production Testing and Quality
Control of the Resilient Block Pads
Of the Low Vibration Track (LVT) System Supplied by
The Permanent Way Corporation

Parsons Transportation Group Inc.
Edwards and Kelcey, Inc. Joint Venture

Accepted
 Accepted as Noted
 Rejected, Revise and Resubmit

Approval is only for general conformance with the design concept of the Project and the information given in the Contract Documents. Contractor is responsible for determining to be confirmed and correlated at the job site; information that pertains solely to the fabrication process or to the means & methods of construction; coordination of the work of all trades; and performing all work in a safe & satisfactory manner. This approval does not modify Contractor's duty to comply with the Contract Documents.

By: *Daniel A. [Signature]* Date: 01-31-03



Jan H. Zichma, P.E.
January 16, 2003

I have applied for the registration in Minnesota and the application is pending.

EXHIBIT C

Doc. No.:	SBP 003.A67
Approval:	BS
Orig. Date:	24 April, 2001
Rev. Level:	A
Rev. Approval:	
Rev. Date:	

Table of Contents

	Page Number
1. ASPECT CONTROL	3
2. DIMENSIONAL CONTROL	3
3. FLATNESS CONTROL	3
3.1 Procedure	3
3.2 Acceptance Criteria	4
4. STATIC DEFLECTION TEST	4
4.1 Procedure	4
4.2 Frequency	4
5. POROSITY MEASUREMENTS	4
5.1 Procedure	4
5.2 Acceptance Criteria	5

Doc. No.:	SBP 003.A67
Approval:	BS
Orig. Date:	24 April, 2001
Rev. Level:	A
Rev. Approval:	
Rev. Date:	

Unless otherwise agreed by the Engineer, batches of block pads shall not exceed 7000 units per batch when presented for inspection.

3 block pads per batch shall be randomly selected for each production control and test specified herein.

If all the control and test results are satisfactory on the 3 block pads, the batch shall be accepted.

If one block pad does not meet all the requirements, the controls and tests shall be repeated on 6 additional randomly selected block pads.

If more than one of the first 3 or any of the additional 6 block pads do not meet the requirements, the batch shall be rejected.

The manufacturer shall, however, have the option to subdivide a rejected batch into 500 unit sub-batches and to repeat the controls and tests on each sub-batch using the same acceptance and rejection criteria as above.

1 Aspect Control

The test block pad shall be visually inspected and found flawless and clean edged. Small surface defects, such as chips or blisters, shall, however, not constitute cause for rejection.

2 Dimensional Control

The dimensional tolerances shall be in accordance with the approved drawing of the pad.

3 Flatness Control

3.1 Procedure

A full block pad shall rest on a flat, level and smooth control surface. A straight, rigid rule shall be laid across the top surface of the pad along its length. The rule shall rest across the pad without compressing it.

The flatness shall be controlled at a minimum of three locations: 1 in. from each edge and at the centerline of the pad. The procedure shall be repeated with the rule placed along the width of the pad. If visible deformations exist in other locations, these locations shall be verified as well in accordance with the same procedure.

Doc. No.:	SBP 003.A67
Approval:	BS
Orig. Date:	24 April, 2001
Rev. Level:	A
Rev. Approval:	
Rev. Date:	

3.2 Acceptance Criteria

No gap or pocket between the rule and the top surface of the pad shall exceed 0.02 in. in depth or 0.8 in. in length.

The vertical distance measured from the bottom edge of the rule on either side of the pad (lengthwise and widthwise) and the control surface shall be in accordance with the thickness dimension and tolerance specified in the approved drawing of the block pad.

4 Static Deflection Test

4.1 Procedure

This test shall be performed at room temperature (+20°C) on a complete block pad.

The loads shall be transmitted to the block pad through a rigid plate. The plate shall be suitably reinforced to guarantee the accuracy of the pad deflection measurements. Prior to the load application, the plate shall rest with all its weight on the pad.

Gauges, positioned at the corners of the loading plate, shall be used to measure the deflection of the pad.

The block pad shall be subjected to 10 preloading cycles between 0 and 12,000 lbs.

The gauges shall be set to zero.

The pad shall be subjected to a loading of 12,000 lbs. The deflections measured by the gauges shall be recorded.

4.2 Acceptance Criteria

The deflection (average of the gauge readings) shall be 0.086in \pm 0.012 in.

5 Porosity Measurement

5.1 Procedure

The porosity of the block pad material shall be tested by a water absorption measurement.

This test shall be performed on a 4x4 in. square sample cut from a block pad.

The thickness (T), initial weight (P0), and volume (V) of the sample shall be measured and recorded.

Doc. No.:	SBP 003.A67
Approval:	BS
Orig. Date:	24 April, 2001
Rev. Level:	A
Rev. Approval:	
Rev. Date:	

The sample shall be submerged in distilled water at room temperature (+20 °C) and compressed between two steel plates down to a thickness equal to 0.70 x T. The sample shall be held in this manner for 1 minute. It shall then be unloaded and maintained free of load for another minute.

This cycle shall be repeated 3 times before the sample is removed from the water.

The sample shall be superficially dried. Its weight P1 shall be measured and recorded.

The amount of water absorbed per unit volume by the sample shall be determined by the following equation:

$$A = \frac{(P1 - P0)}{V}$$

5.2 Acceptance Criteria

The value of A must not exceed 0.000036 lb/in³.

Doc. No.:	SRB003.A67
Approval:	BS
Orig. Date:	24-April, 2001
Rev. Level:	A
Rev. Approval:	
Rev. Date:	

Hiawatha Corridor Light Rail Project
MNDOT Agreement No. 80356
Railworks Track Systems, Inc.

Production Testing and Quality
Control of the Rubber Boots
Of the Low Vibration Track (LVT) System Supplied by
The Permanent Way Corporation



Jan H. Ticha, P.E.
January 16, 2003

I have applied for the registration in
Minnesota and the application is pending.

Parsons Transportation Group Inc.
Edwards and Keicey, Inc. Joint Venture

Accepted
 Accepted as Noted
 Rejected, Revise and Resubmit

Approval is only for general conformance with the design concept of the Project and the information given in the Contract Documents. Contractor is responsible for dimensions to be confirmed and correlated at the job site; information that pertains solely to the fabrication process or to the means & methods of construction; coordination of the work of all trades; and performing all work in a safe & satisfactory manner. This approval does not modify Contractor's duty to comply with the Contract Documents.

By: *David Ticha* Date: 01-31-03

EXHIBIT D

Doc. No.: SRB003.A67
Approval: ES
Orig. Date: 24 April, 2001
Rev. Level: A
Rev. Approval:
Rev. Date:

Table of Contents

	Page Number
1. ASPECT CONTROL	3
2. DIMENSIONAL CONTROL	3
3. MEASUREMENT OF THE SHORE A HARDNESS	3
3.1 Procedure	3
3.2 Acceptance Criteria	3
4. MEASUREMENT OF THE ULTIMATE STRENGTH AND ELONGATION AT BREAK	4
4.1 Procedure	4
4.2 Acceptance Criteria	4

Doc. No.: SRB003.A67
Approval: BS
Orig. Date: 24 April, 2001
Rev. Level: A
Rev. Approval: _____
Rev. Date: _____

Unless otherwise agreed by the Engineer, batches of rubber boots shall not exceed 7000 units per batch when presented for inspection.

3 rubber boots per batch shall be randomly selected for testing.

If all the test results are satisfactory on the 3 rubber boots, the batch shall be accepted.

If one rubber boot does not meet all the requirements, all the tests shall be repeated on 6 additional randomly selected rubber boots.

If more than one of the first 3 or any of the additional 6 rubber boots do not meet the requirements, the batch shall be rejected.

The manufacturer shall, however, have the option to subdivide a rejected batch into 500 unit sub-batches and to repeat the tests on each sub-batch using the same acceptance and rejection criteria as above.

1 Aspect Control

The rubber boot shall be visually inspected and found flawless and clean edged. Small surface defects, such as chips or blisters, shall, however, not constitute cause for rejection.

2 Dimensional Control

The dimensional tolerances of the rubber boot shall be in accordance with the approved drawing of the boot.

3 Measurement of the Shore A Hardness

3.1 Procedure

The Shore A hardness of the boot material shall be measured according to ASTM D2240, indentation hardness of rubber and plastics by means of a durometer. Measurements shall be made at five points on the upper surface of the boot base.

3.2 Acceptance Criteria

The average of the measured values must fall between 74° and 80° Shore A.

Doc. No.: SRB003.A67
Approval: BS
Orig. Date: 24 April, 2001
Rev. Level: A
Rev. Approval:
Rev. Date:

4 Measurement of the Ultimate Strength and Elongation at Break

4.1 Procedure

12 samples (6 longitudinal and 6 transversal) shall be cut from the base of the boot according to ASTM D412, method A, die C. The thickness of the samples shall correspond to that of the base of the boot.

The ultimate strength and the elongation at break shall be measured on six samples (3 longitudinal and 3 transversal).

The remaining 6 samples (3 longitudinal and 3 transversal) shall be artificially aged according to ASTM D573 for 72 hours in an oven maintained at a temperature of $100^{\circ}\text{C} \pm 1^{\circ}\text{C}$. The ultimate tensile strength and the elongation at break shall be measured after cooling the samples at room temperature ($+20^{\circ}\text{C}$) for not less than 16 hours.

4.2 Acceptance Criteria

For each set, the median value of the three measures shall be recorded and the values shall meet the following criteria:

- Minimum tensile strength of the initial section:

- before ageing - 1740 psi
- after ageing - 1450 psi

- Minimum elongation at break:

- before ageing - 250%
- after ageing - 180%

LVT SUPPORTS

Permanent Transportation Group Inc.
Folwerth and Laksey, Inc. Joint Venture

DESIGN DOCUMENT FOR HIAWATHA LRT



- Approved
- Accepted as Noted
- Rejected, Revise and Resubmit

proval is only for general conformance with the design concept of the Project and the information given in the contract Documents. Contractor is responsible for dimensions be confirmed and correlated at the job site; information that re solely to the fabrication process or to the means & methods of construction; coordination of the work of all trades; and performing all work in a safe & satisfactory manner. This proval does not modify Contractor's duty to comply with the contract Documents.

Jan R. Ticha, P.E. January 16, 2003
I have applied for the registration in Minnesota and the application is pending.

David A. [Signature] Date: *01-31-03*

SUBMITTED BY:

THE PERMANENT WAY CORPORATION

8109 TIS WELL DRIVE SUITE 513
ALEXANDRIA, VIRGINIA 22306
USA

TELEPHONE: 1 +(703) 619-1532
FACSIMILE: 1 +(703) 619-1534
E-mail: pwc@sonneville.com

© 2001
This document has copyright which is owned by The Permanent Way Corporation (PWC) and may not be reproduced, in whole, in part, or in any form whatsoever without prior written authority from PWC. This document has been submitted on the understanding that it will not be used in any way against the interests of PWC.

Doc. No.:	DCA075B.A67
Approval:	ATB
Orig. Date:	12 July 2001
Rev. Level:	B
Rev. Approval:	BS
Rev. Date:	13 August, 2001

CONTENTS

1	Introduction	4
2	Executive summary	4
2.1	Spring Rates & track modulus	4
2.2	Distribution factor	4
2.3	Rail deflection	4
2.4	Vertical and lateral forces on trackbase concrete	5
2.5	Requirement for encasement concrete reinforcement	5
2.6	Block calculations	5
3	Basis of design & design input data	5
3.1	Track geometry	5
3.2	Nominal loading from rolling stock	5
4	Design assumptions	5
4.1	Dynamic load factors	5
4.2	L/V ratio	6
5	Spring rates & track modulus	6
6	Distribution factor	6
6.1	Theory	6
6.2	Input and results	7
7	Rail deflection calculations	7
7.1	Rail deflection for nominal impact factor	7
8	LVT SUPPORT Load distribution and block displacement calculations	8
8.1	Theory	8
8.2	Input	8
8.2.1	Loads	8
8.2.2	Block pad	8
8.2.3	Rubber boot	8
8.2.4	Block geometry	9
8.3	Results L/V = 0.5	9
8.3.1	Angle of block inclination:	9
8.3.2	Distributed loads:	9
8.3.3	Pressures Exerted on Trackbase Concrete:	9

Doc. No.:	DCA075B.A67
Approval:	ATB
Orig. Date:	12 July 2001
Rev. Level:	B
Rev. Approval:	BS
Rev. Date:	13 August, 2001

8.3.4	Block Displacement:	10
8.3.5	Lateral deflection of rail head due to the displacement of the support:	10
8.4	Results $L/V = 1$	10
8.4.1	Loads	10
8.4.2	Block geometry	11
8.4.3	Angle of block inclination:	11
8.4.4	Distributed loads:	11
8.4.5	Pressures Exerted on Trackbase Concrete:	11
8.4.6	Block Displacement:	11
8.4.7	Lateral deflection of rail head due to the displacement of the support:	12
9	Rail Support Calculations	12
9.1	Summary of Results	12
9.2	Design Positive Bending Moment	13
9.3	Uncracked Section Calculations	13
9.3.1	Steel Areas:	13
9.3.2	Transformed steel areas:	13
9.3.3	Section Modulus	14
9.3.4	Stresses:	14
9.4	Cracked section calculations	15
9.4.1	Location of neutral axis	15
9.4.2	Moment of inertia of cracked section	15
9.4.3	Stresses:	15
10	Summary	15
10.1	Conclusions	15
10.2	References	16
11	Annexure	16

Doc. No.:	DCA075B A67
Approval:	ATB
Orig. Date:	12 July 2001
Rev. Level:	B
Rev. Approval:	BS
Rev. Date:	13 August, 2001

1 Introduction

The purpose of the calculations below is to analyze and evaluate the loading conditions congruent with Hiawatha LRV traffic equipped with The Permanent Way Corporation's Low Vibration Track.

The results of these calculations verify the validity of the LVT design in terms of:

- ◆ Component spring rates and track modulus.
- ◆ Lateral resistance of the track.
- ◆ Resistance of the concrete blocks.

The LVT system comprises two resilient levels (the rail pad and the block pad) separated by an intermediate mass (the concrete block). The resiliency and high damping achieved at the block pad level do not affect the integrity of the rail fastenings. In addition, the block pad has a high level of elastic reserve which allows the system to accommodate occasional severe impact loads (impacts greater than those covered in this calculation) without critical failure of any of the LVT components or detrimental effects to the track or system.

2 Executive summary

The reference values and computing methods contained herein are backed by laboratory test results and a proprietary model developed by The Permanent Way Corporation.

2.1 Spring Rates & track modulus

The spring rates specified for the resilient components of the non ballasted trackform yield:

$$K_s = \text{global spring rate of a block } 130,476 \text{ lb./in.}$$

$$K_T = \text{track modulus for } d_1 \text{ 30 in. } = 4348 \text{ lb./in.in.}$$

2.2 Distribution factor

The spring rate characteristics of the block combined with the track geometry and properties of the rail profile yield a distribution factor, for d_1 (30 in.) = D_p , of 0.41.

2.3 Rail deflection

The 130,476 lb./in. block spring rate and the 0.41 distribution factor yield a rail deflection of 0.072 in. for nominal loading conditions corresponding to 30,450 lb. axle loads and a (1+ 0.5) impact factor.

Doc. No.:	DCA075B.A67
Approval:	ATB
Orig. Date:	12 July 2001
Rev. Level:	B
Rev. Approval:	BS
Rev. Date:	13 August, 2001

2.4 Vertical and lateral forces on trackbase concrete

The pressures exerted by the base of the block on the trackbase concrete were calculated under combined vertical and lateral forces per block for loading conditions of CASE 1: $L/V = 0.5$ (standard assumption in the industry) and CASE 2: $L/V = 1$ (extreme assumption imposed on The Permanent Way Corporation for these project specific calculations).

2.5 Requirement for encasement concrete reinforcement

Assuming a conservative compressive strength value for the encasement concrete of ≥ 5000 psi and using 500 psi as the tensile strength, the comparatively low forces transferred to the encasement concrete justify the standard practice of not reinforcing the encasement concrete and not installing steel connections between the encasement concrete and the civil works.

2.6 Block calculations

The stresses in the blocks corresponding to a 9,350 lb. vertical load per block have been calculated and found well below the allowable stresses recommended by the American Concrete Institute.

3 Basis of design & design input data

3.1 Track geometry

- ◆ The rails shall be supported on individual blocks at 30 in. spacing.
- ◆ The running rails shall be 115 rails, installed at a $1:40^\circ$ inclination.
- ◆ Track gauge shall be 4' 8.5".

3.2 Nominal loading from rolling stock

The standard design loading shall be as follows:

Maximum normal axle load of 30,450 lb., operating speed 55 mph.

4 Design assumptions

4.1 Dynamic load factors

Nominal impact factor shall be $(1+0.5)$ or 50 % over the static wheel load.

Doc. No.:	DCA075B.A67
Approval:	ATB
Orig. Date:	12 July 2001
Rev. Level:	B
Rev. Approval:	BS
Rev. Date:	13 August, 2001

4.2 L/V ratio

CASE 1: $L/V = 0.5$

CASE 2: $L/V = 1$

The L/V ratio shall be used to determine the lateral forces applied to the trackform. This ratio takes into account all lateral forces exerted on the track and includes a safety factor which is increased for tangent track.

5 Spring rates & track modulus

K_{mp}	= spring rate of the block pad	= 142,750 lb./in.
K_{rp}	= spring rate of the rail pad	= 1,750,000 lb./in.
K_b	= spring rate of the boot base	= 11,420,000 lb./in.
K_s	= global spring rate of a block	

The relationship between the global spring rate of the block and that of its resilient components is given by:

$$1/K_s = 1/K_{mp} + 1/K_{rp} + 1/K_b$$

This expression yields: $K_s = 130,476 \text{ lb./in.}$

The value of the track modulus is given by:

$$K_T = \text{track modulus} = K_s/d \quad \text{where: } d = \text{spacing between blocks} = 30 \text{ in.}$$

$$K_T = 4348 \text{ lb./in.in.}$$

6 Distribution factor

6.1 Theory

The force carried by a single block (i.e. block reaction R_s) located at the point of wheel load is given by Zimmermann as:

$$R_s = \frac{d Q}{\sqrt{8}} (K_T/EI)^{1/4}$$

Where:

$$R_s = \text{block reaction} = y K_s$$

Doc. No.:	DCA075B_A67
Approval:	ATB
Orig. Date:	12 July 2001
Rev. Level:	B
Rev. Approval:	BS
Rev. Date:	13 August, 2001

- K_s = global spring rate of a block,
 - y = rail deflection
 - d = spacing of support blocks
 - Q = factored wheel load
 - E = Young's modulus for rail steel
 - I = moment of inertia of the rail section
- K_T = track modulus = K_s/d

The distribution factor can thus be expressed as follows:

$$D_F = \frac{R_s}{Q} = \frac{d}{\sqrt{8}} (K_s/dEI)^{1/4}$$

6.2 Input and results

- $K_s = 130,476$ lb./in.
- $d_1 = 30$ in.
- Axle loads = 30,450 lb.
- Nominal impact factor = (1 + 0.5)
- $Q = (\text{axle load} / 2) \times \text{IF} = (30,450 / 2) \times (1 + 0.5) = 22,838$ lb.
- $E = 29,000,000$ psi
- $I = 65.6$ in⁴ (for 115 lb. rail)

Calculated distribution factor: $D_F = 0.41$

7 Rail deflection calculations

7.1 Rail deflection for nominal impact factor

The deflection of the rail under an applied force is given by:

$$y = Q D_F / K_s$$

Where:

- y = rail deflection
- Q = factored wheel load
- D_F = distribution factor
- $Q * D_F$ = load transmitted to one support
- K_s = global spring rate of a block = 130,476 lb./in.

For the nominal impact factor:

$$Q = (30,450 \text{ lb.} / 2) \times (1 + 0.5) = 22,838 \text{ lb.}$$

Doc. No.:	DCA075B.A67
Approval:	ATB
Orig. Date:	12 July 2001
Rev. Level:	B
Rev. Approval:	BS
Rev. Date:	13 August, 2001

$$Q * D_F = 22,838 \text{ lb.} * 0.41 = 9,350 \text{ lb.}$$

$$y = 0.072 \text{ in.}$$

8 LVT SUPPORT Load distribution and block displacement calculations

8.1 Theory

The model used to obtain the following results is detailed in document no. DCA001.GN, see Annexure "LVT Rail Support".

$$S^\circ = \text{Angle of } F_{\text{resultant}} \text{ with respect to vertical plane,} = 26.6^\circ$$

8.2 Input

8.2.1 Loads

$F_v = \text{wheel load} \times \text{impact factor} \times \text{distribution factor}$

$$F_v = (30,450 \text{ lb./2}) \times (1 + 0.5) \times 0.41 = 9,350 \text{ lb.,}$$

For L/V ratio = 0.5

$$F_H = 0.5 \times F_v = 4,675 \text{ lb.,}$$

8.2.2 Block pad

Block pad spring rate = 142,750 lb./in

Block pad effective length = 25.0 in.

Block pad effective width = 10.2 in.

Spring rate of block pad per unit length = $R_p = 5,710 \text{ lb./in.in.}$

8.2.3 Rubber boot

Boot effective height = 5.0 in.

Boot effective width = 10.6 in.

Doc. No.:
Approval:
Orig. Date:
Rev. Level:
Rev. Approval:
Rev. Date:

DCA075B.A67
ATB
12 July 2001
B
BS
13 August 2001

Unit spring rate of boot wall = $9,578 \text{ lb./in.in.}^2$

Spring rate of boot per unit width = $R_b = 9,578 \text{ lb./in.in.}^2 \times 10.6 \text{ in.}$
 $R_b = 101,812 \text{ lb./in.in.}$

Force due to the shear deformation of the boot's corrugations = $F_b = 2,121 \text{ lb.}$

The contribution of the boot walls used in these calculations was derived from measurements made during tests performed under combined vertical and lateral loads (Technical University of Munich's report number 1330b). However, the boot walls had no influence on the spring rate of the block pad under vertical loads. Identical spring rates were measured under vertical loads on block pads tested within the assembled LVT system encased in concrete and on samples tested separately (T.U.M. report 1330b).

8.2.4 Block geometry

(see Annexure Drawing)

- $L_1 = 10.7 \text{ in.}$
- $L_2 = 14.5 \text{ in.}$
- $L = 25.2 \text{ in.}$
- $h_1 = 5.0 \text{ in.}$
- $h_2 = 8.2 \text{ in.}$

8.3 Results $L/V = 0.5$

8.3.1 Angle of block inclination:

$$= 0.034^\circ$$

8.3.2 Distributed loads:

- $W_1 = 244 \text{ lb./in.}$
- $W_2 = 85 \text{ lb./in.}$
- $W_3 = 793 \text{ lb./in.}$
- $W_4 = 299 \text{ lb./in.}$

8.3.3 Pressures Exerted on Trackbase Concrete:

At point A: $P_A = W_1/\text{pad width} = 24 \text{ psi}$

Doc. No.:	DCA075B.A67
Approval:	ATB
Orig. Date:	12 July 2001
Rev. Level:	B
Rev. Approval:	ES
Rev. Date:	13 August, 2001

At point B: $P_B = (W_1 + W_2) / \text{pad width} = 32 \text{ psi}$

At point C: $P_C = W_3 / \text{boot width} = 75 \text{ psi}$

At point D: $P_D = (W_3 + W_4) / \text{boot width} = 103 \text{ psi}$

Note: Encasement concrete strength $\geq 5000 \text{ psi}$ compressive
 $\geq 500 \text{ psi}$ tensile

8.3.4 Block Displacement:

At point A: $A = W_1 / R_p = 0.043 \text{ in.}$

At point B: $B = (W_1 + W_2) / R_p = 0.058 \text{ in.}$

At point C: $C = W_3 / R_b = 0.008 \text{ in.}$

At point D: $D = (W_3 + W_4) / R_b = 0.011 \text{ in.}$

8.3.5 Lateral deflection of rail head due to the displacement of the support:

-Lateral displacement of the base of the support (at point c) = 0.008 in.

-Displacement due to the tilting of the rail support
 $(h_1 + h_2) \tan = (5.0 + 8.2) \tan 0.034^\circ = 0.008 \text{ in.}$

Total lateral deflection of rail head = $0.008 + 0.008 = 0.016 \text{ in.}$

8.4 Results $L/V = 1$

$S^\circ = \text{Angle of } F_{\text{resultant}} \text{ with respect to vertical plane,} = 45.0^\circ$

8.4.1 Loads

$F_v = \text{wheel load} \times \text{impact factor} \times \text{distribution factor}$

$F_v = (30,450 \text{ lb./2}) \times (1 + 0.5) \times 0.41 = 9,350 \text{ lb.,}$

For L/V ratio = 1

Doc. No.:
Approval:
Orig. Date:
Rev. Level:
Rev. Approval:
Rev. Date:

DCA075B.A67
ATB
12 July 2001
B
BS
13 August, 2001

$$F_H = 1 \times F_v = 9,350 \text{ lb.},$$

8.4.2 Block geometry

(see Annexure Drawing)

$$\begin{aligned}L_1 &= 10.7 \text{ in.} \\L_2 &= 14.5 \text{ in.} \\L &= 25.2 \text{ in.} \\h_1 &= 5.0 \text{ in.} \\h_2 &= 8.2 \text{ in.}\end{aligned}$$

8.4.3 Angle of block inclination:

$$= 0.364^\circ$$

8.4.4 Distributed loads:

$$\begin{aligned}W_1 &= 0 \text{ lb./in.} \\W_2 &= 915 \text{ lb./in.} \\W_3 &= 279 \text{ lb./in.} \\W_4 &= 3213 \text{ lb./in.}\end{aligned}$$

8.4.5 Pressures Exerted on Trackbase Concrete:

$$\begin{aligned}\text{At point A:} \quad P_A &= W_1/\text{pad width} = 0 \text{ psi} \\ \text{At point B:} \quad P_B &= (W_1 + W_2)/\text{pad width} = 73 \text{ psi} \\ \text{At point C:} \quad P_C &= W_3/\text{boot width} = 26 \text{ psi} \\ \text{At point D:} \quad P_D &= (W_3 + W_4)/\text{boot width} = 328 \text{ psi}\end{aligned}$$

Note: Encasement concrete strength ≥ 5000 psi compressive
 ≥ 500 psi tensile

8.4.6 Block Displacement:

$$\begin{aligned}\text{At point A:} \quad A &= W_1/R_p = 0 \text{ in.} \\ \text{At point B:} \quad B &= (W_1 + W_2)/R_p = 0.130 \text{ in.}\end{aligned}$$

Doc. No.:	DCA075B.A67
Approval:	ATB
Orig. Date:	12 July 2001
Rev. Level:	B
Rev. Approval:	BS
Rev. Date:	13 August, 2001

At point C: $c = W_3/R_b = 0.003 \text{ in.}$

At point D: $D = (W_3 + W_4)/R_b = 0.034 \text{ in.}$

8.4.7 Lateral deflection of rail head due to the displacement of the support:

-Lateral displacement of the base of the support (at point c) = 0.003 in.

-Displacement due to the tilting of the rail support
 $(h_1 + h_2) \tan = (5.0 + 8.2) \tan 0.364^\circ = 0.084 \text{ in.}$

Total lateral deflection of rail head = 0.003 + 0.084 = 0.086 in.

9 Rail Support Calculations

These calculations have been performed to evaluate the structural integrity of the concrete supports of the non ballasted track.

Values for compression and tensile stresses in concrete or steel sections have been computed using the working stress method.

The first set of calculations (uncracked-full section) accounts for the full cross section of the support, while the second set (cracked section) does not take into consideration any contribution from the concrete located in the tensile area of the support's cross section. This second hypothesis provides a conservative estimate of the maximum concrete and steel stresses generated by the design bending moment.

9.1 Summary of Results

First set of calculations, uncracked (full) cross-section

Compression (concrete)	=	287 psi
Tension (concrete)	=	284 psi
Tension (lower reinf. steel)	=	1169 psi

Second set of calculations, cracked LVT cross-section

Compression (concrete)	=	343 psi
Tension (lower reinf. steel)	=	3727 psi

Doc. No.:	DCA075B.A67
Approval:	ATB
Orig. Date:	12 July 2001
Rev. Level:	B
Rev. Approval:	BS
Rev. Date:	13 August, 2001

These values may be compared with the allowable stresses recommended by the American Concrete Institute (ACI):

Concrete in compression: $0.45 f_c' = 3150$ psi
 Concrete in tension: $0.62 f_c'^{1/2}(\text{MPa}) = 625$ psi
 Steel in tension: $0.40 f_y = 24,000$ psi

9.2 Design Positive Bending Moment

The following calculations consider the load corresponding to the 30,450 lb. axle load.

Support reaction: $R_s = \text{wheel load} \times \text{impact factor} \times \text{distribution factor}$:

$$R_s = 30,450 / 2 \times (1 + 0.5) \times 0.41 = 9,350 \text{ lb.}$$

For a rail support bearing over its full length on a resilient block pad, the maximum positive bending moment is given by:

$$M = (R_s/8) (L - R_r) \quad \begin{array}{l} L = \text{support length} = 25.20 \text{ in.} \\ R_r = \text{rail foot width} = 5.50 \text{ in.} \end{array}$$

$$M = (9,350 \text{ lb.}/8) (25.20 - 5.50) \text{ in.} = 23,021 \text{ lb.in.}$$

9.3 Uncracked Section Calculations

(See Annexure Drawing)

9.3.1 Steel Areas:

$$A_{s1} = 4 \text{ bars @ } \varnothing 0.500 \text{ in.} = 0.79 \text{ in.}^2$$

$$A_{s2} = \text{angle } 2.5" \times 2.5" \times 1/4 = 1.18 \text{ in.}^2$$

$$A_{s3} = 4 \text{ bars @ } \varnothing 0.315 \text{ in.} = 0.31 \text{ in.}^2$$

$$I_{xx} = 7.21 \text{ in.}^4$$

Yield strength of steel reinforcements:

$$F_y = 60,000 \text{ psi}$$

Concrete strength:

$$F_c' = 7000 \text{ psi}$$

$$E_s = 29,000,000 \text{ psi}$$

$$E_c = 5000 F_c'^{1/2}$$

$$n = E_s/E_c = \sim 6$$

Doc. No.:
 Approval:
 Orig. Date:
 Rev. Level:
 Rev. Approval:
 Rev. Date:

DCA075B.A67
 ATB
 12 July 2001
 B
 BS
 13 August, 2001

9.3.2 Transformed steel areas:

$$\begin{aligned} A_{s_1}(n-1) &= 0.79 \text{ in.}^2 \times 5 = 3.93 \text{ in.}^2 \\ A_{s_2}(n-1) &= 1.18 \text{ in.}^2 \times 5 = 5.89 \text{ in.}^2 \\ A_{s_3}(n-1) &= 0.31 \text{ in.}^2 \times 5 = 1.56 \text{ in.}^2 \end{aligned} \quad I_{xx} = 1.38 \text{ in.}^4$$

Section	$A_i(\text{in}^2)$	$Y_i(\text{in})$	$A_i Y_i(\text{in}^3)$	$A_i Y_i^2(\text{in}^4)$	$I_i(\text{in}^4)$
Ac	66.52	3.20	212.9	681.2	227.1
As ₁	3.93	1.00	3.9	3.9	---
As ₂	5.89	3.87	22.8	88.2	1.4
As ₃	1.56	5.46	8.5	46.4	---
	77.9		248	819.7	228.4

$$y = \frac{a_i Y_i}{a_i} = \frac{248}{77.9} = 3.19 \text{ in. from bottom}$$

$$\begin{aligned} I &= I_i + A_i Y_i^2 - (A_i) Y^2 \\ &= 228.4 + 819.7 - 77.9 \times 3.19^2 = 258.02 \text{ in}^4 \end{aligned}$$

9.3.3 Section Modulus

$$S_T = \frac{I}{Y} = \frac{258.02 \text{ cm}^4}{(6.40 - 3.19) \text{ in}} = 80.25 \text{ in}^3$$

$$S_B = \frac{I}{Y} = \frac{258.02 \text{ cm}^4}{(3.19) \text{ in}} = 81.01 \text{ in}^3$$

9.3.4 Stresses:

For the design bending moment $M = 23,021 \text{ lb.in.}$

$$\text{Top concrete (compression): } = \frac{M}{S_T} = \frac{23,021}{80.25} = 287 \text{ psi}$$

$$\text{Bottom concrete (tension): } = \frac{M}{S_B} = \frac{23,021}{81.01} = 284 \text{ psi}$$

Doc. No.:
 Approval:
 Orig. Date:
 Rev. Level:
 Rev. Approval:
 Rev. Date:

DCA075B.A67
ATB
12 July 2001
B
BS
13 August, 2001

$$\text{Bottom steel (tension):} = \frac{nMY}{I} = \frac{6 \times 23,021 \times (3.19 - 1.000)}{258.02} = 1169 \text{ psi}$$

9.4 Cracked section calculations

(See Annexure Drawing)

9.4.1 Location of neutral axis

M about neutral axis = 0

$$nAs_1(5.400 - Kd) + nAs_2(2.530 - Kd) = (n-1)As_3(Kd - 0.939) + 0.5 \times 10.39 Kd^2$$

$$6 \times 0.79 (5.400 - Kd) + 6 \times 1.18 (2.530 - Kd) = 5 \times 0.31 (Kd - 0.939) + 5.20 Kd^2$$

$$Kd = 1.92 \text{ in from top}$$

9.4.2 Moment of inertia of cracked section

$$I = nAs_1(5.400 - kd)^2 + nAs_2(2.530 - Kd)^2 + n \times 7.21 + (n-1)As_3(Kd - 0.939)^2 + 10.39 Kd^3/3$$

$$I = 6 \times 0.79 (5.400 - 1.92)^2 + 6 \times 1.18 (2.530 - 1.92)^2 + 6 \times 7.21 + 5 \times 0.31 (1.92 - 0.939)^2 + 10.39 \times 1.92^3/3$$

$$I = 0.013 \text{ in}^4$$

9.4.3 Stresses:

For the design bending moment $M = 23,021 \text{ lb.in.}$

$$\text{Top concrete (compression):} = \frac{MY}{I} = \frac{23,021 \times 1.92}{0.013} = 343 \text{ psi}$$

$$\text{Bottom steel (tension):} = \frac{nMY}{I} = \frac{6 \times 23,021 \times (5.400 - 1.92)}{0.013} = 3727 \text{ psi}$$

10 Summary

10.1 Conclusions

Doc. No.:	DCA675B.A67
Approval:	ATB
Orig. Date:	12 July 2001
Rev. Level:	B
Rev. Approval:	BS
Rev. Date:	13 August, 2001

All relevant loads have been taken into consideration.
 Rail stresses and pressures exerted on the trackbase concrete remain acceptable in all cases.
 The particular specifications for the blocks and resilient components reflect the results of experience and the design calculations.
 LVT has extensive experience in revenue service in addition to thorough laboratory and qualification testing.

10.2 References

From 1991, over 260 km (160 miles) of LVT have been in revenue service, are currently being or will be installed on the following properties:

- P.A.T.H., New York-New Jersey
- Channel Tunnel, England-France
- Metrolink, St Louis, Missouri
- Grauholz Tunnel, SBB, Switzerland
- B.A.R.T., Colma, California
- MARTA, Atlanta, Georgia
- D.A.R.T., Dallas, Texas
- Tri-Met, Portland, Oregon
- Lantau and Airport Railway, MTRC, Hong Kong
- Incheon Metro, Korea
- Rio Metro, Brazil
- Øresund Tunnel, Denmark
- MTA, Los Angeles, California
- D.O.T., Connecticut
- Amtrak, Newark, New Jersey
- Copenhagen Metro, Denmark
- Quarry Bay, MTRC, Hong Kong
- Tseung Kwan O, MTRC, Hong Kong
- West Rail, KCRC, Hong Kong
- Trensurb, Porto Alegre, Brazil
- B.A.R.T., San Francisco Airport Extension, California



*Jan N. Zicha, P.E.
 January 16, 2003*

11 Annexure

Block Geometry
 Sketch: EN/558/A67

*I have applied for the registration in
 Minnesota and the application is pending.*

Doc. No.:	DCA075B.A67
Approval:	ATB
Orig. Date:	12 July 2001
Rev. Level:	B
Rev. Approval:	BS
Rev. Date:	13 August, 2001

Rail Support Calculations:

Sketch: EN/559/A67

LVT Rail Support

Doc. Code: DCA001.GN

Load distribution and block displacement model Sketch: PS/214

Doc. No.:
 Approval:
 Orig. Date:
 Rev. Level:
 Rev. Approval:
 Rev. Date:

DCA075B.A67
 ATB
 12 July 2001
 B
 BS
 13 August, 2001

LOADING DIAGRAM

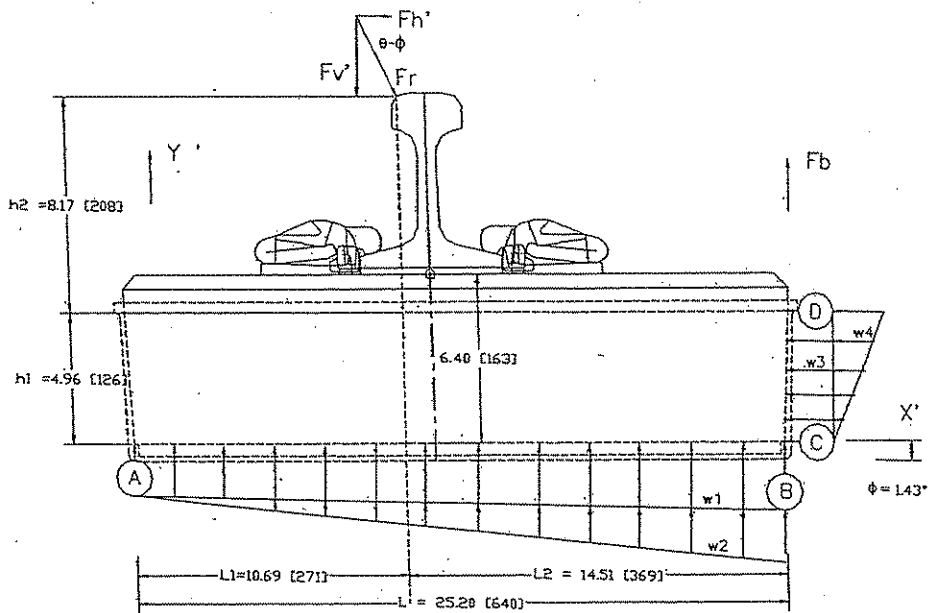

THE PERMANENT WAY CORPORATION

SUBJECT:
 LOADING DIAGRAM
 LOW PROFILE LVT SUPPORTS

DATE: 12 JULY 2001

DR. No. ENS58A67

DOC. REF.:

Doc. No.:
 Approval:
 Orig. Date:
 Rev. Level:
 Rev. Approval:
 Rev. Date:

DCA075B.A67
ATB
12 July 2001
B
BS
13 August, 2001

FULL SECTION DIAGRAM

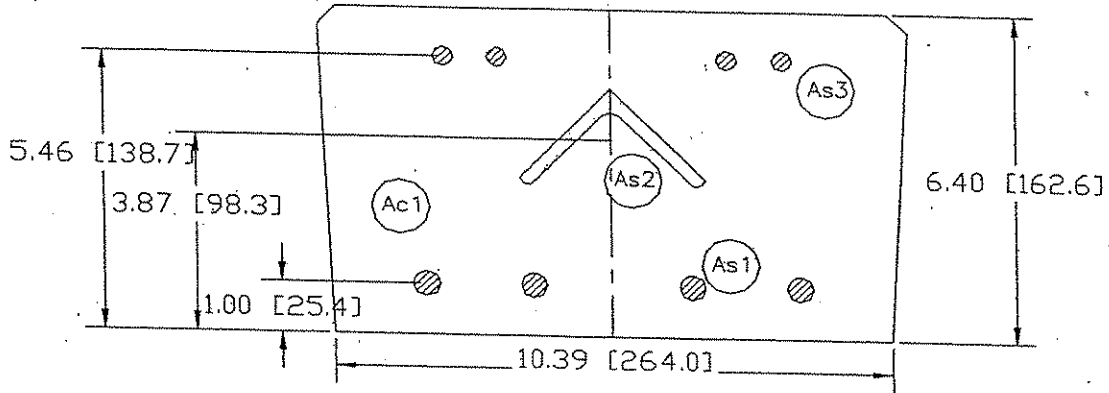

CRACKED SECTION DIAGRAM

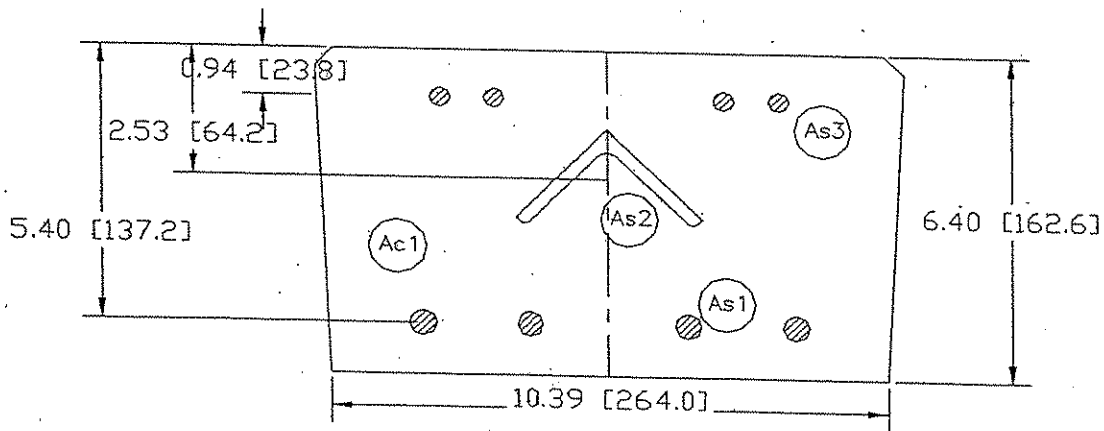

NOT TO SCALE

THE PERMANENT WAY CORPORATION	SUBJECT: LOW PROFILE LVT SUPPORTS SECTION DIAGRAM	DATE: 12 JULY 2001
		DR. No: EN559A67
		DOC. REF.:

LVT Rail Support

Load Distribution and Rail Support Displacement Model

Introduction

The object of this model is to determine the distribution of the rail loads on the phase II concrete which encases the base of the rail support. The model also calculates the support's displacement and angle of inclination under a given rail load.

The elements of the model are:

Model inputs:

- Rail loads.
- Configuration of the rail support.
- Properties of the elastomeric components.

Model outputs:

- Lateral translation, vertical translation, and rotation of the rail support under the given loads.
- Magnitude and distribution of forces on the base and field end of the rail support.

The model is based on the balance of the forces acting on the rail support. An outline of its derivation is given in this note.

Assumptions and explanation of inputs used in calculations

Horizontal forces

The load F_h is carried entirely by the independent rail support. The distributed loads w_3 and w_4 represent the boot wall's resistance to the tilting and horizontal displacement of the block.

Vertical forces

The vertical load F_v is counteracted by two distributed loads on the base of the block (w_1 , w_2 represent the block pad's resistance to the tilting and vertical displacement of the block), and by a

vertical force F_b acting on the field side of the block. The force F_b represents the resistance of the boot wall corrugations to a vertical deflection of the block.

Derivation of the equations

The loading and geometry of the track system is shown in the enclosed sketch.

Taking the sum of moments about point (0,0):

$$M_o = 0 =$$

$$0 = 1/2 W_1 L^2 + 1/3 W_2 L^2 + 1/2 W_3 h_1^2 + 1/3 W_4 h_1^2 + F_b L - F_H (h_1 + h_2) - F_v L_1$$

Sum of horizontal forces:

$$F_x = 0 = F_H - W_3 h_1 - 1/2 W_4 h_1$$

$$W_3 = (F_H - 1/2 W_4 h_1) \frac{1}{h_1}$$

Sum of vertical forces:

$$F_y = 0 = W_1 L + 1/2 W_2 L + F_b - F_v$$

$$W_1 = (F_v - 1/2 W_2 L - F_b) \frac{1}{L}$$

For the block pad:

$$W_2 = L R_p \tan$$

Where $R_p \equiv$ spring rate of the pad

\equiv angle of block tilting under the load

For the boot (field side wall):

$$W_4 = h_1 R_b \tan$$

Where R_p = spring rate of boot wall

= angle of block tilting under the load

Substituting these values in the sum of moments equation:

$$0 = 6 F_v (L_2 - L_1) + 6F_bL - 6F_Hh_1 - 12F_Hh_2 + R_pL^3 \tan \theta + R_bh_1^3 \tan \theta$$

Solving for $\tan \theta$:

$$\tan \theta = \frac{6F_v (L_1 - L_2) + 6F_H (h_1 + 2h_2) - 6 F_bL}{R_p L^3 + R_bh_1^3}$$

INDEPENDENT-RAIL SUPPORT
LOAD DISTRIBUTION CALCULATIONS

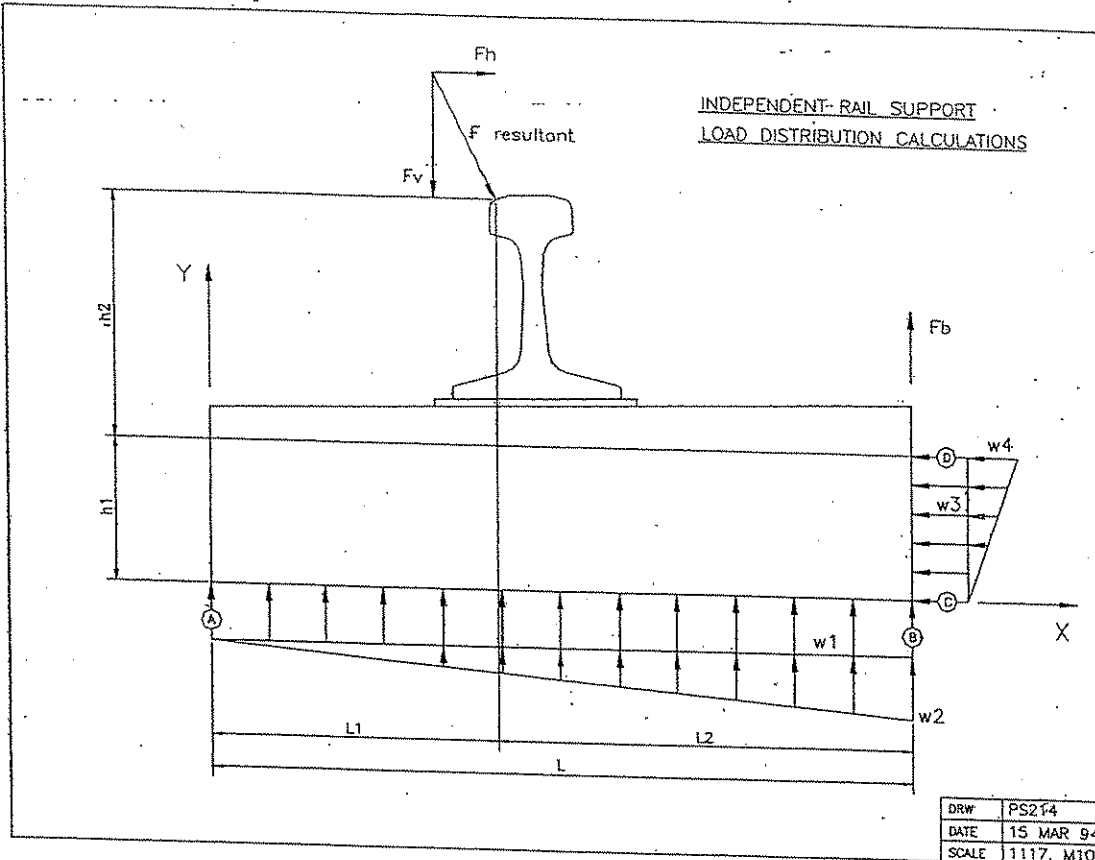

DRW	PS214
DATE	15 MAR 94
SCALE	1117, M10

4 INCH ON ORIGINAL

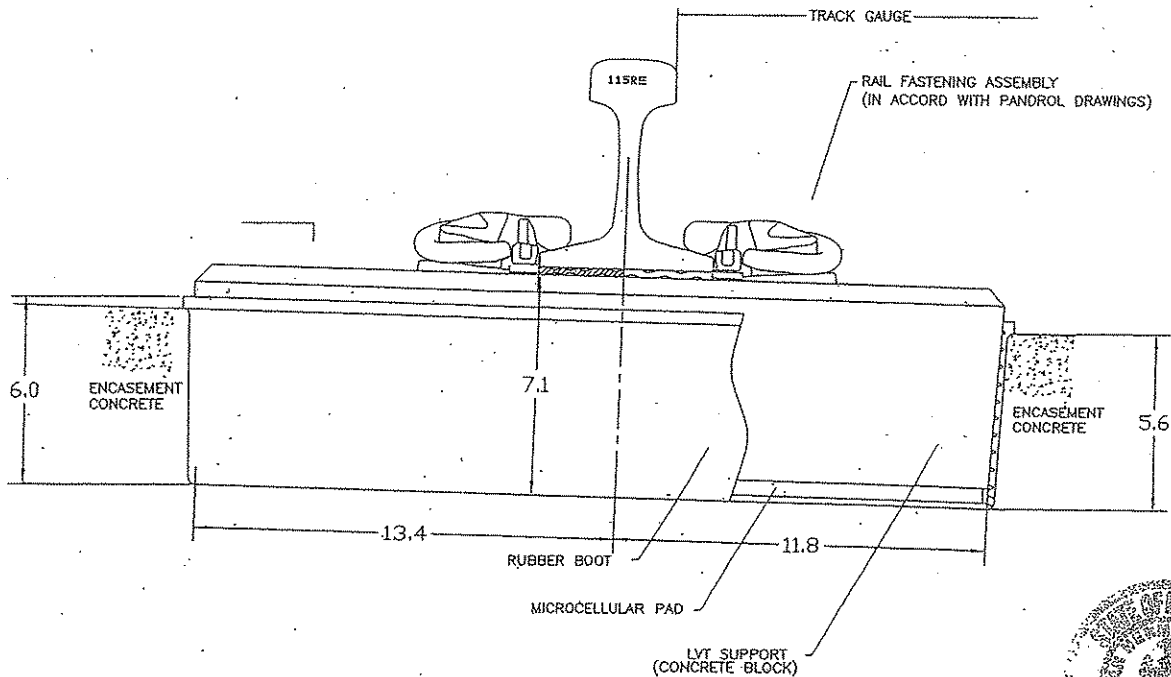

James W. Rich, P.E. January 15, 2003

I have applied for the registration in Minnesota and the application is pending.

ALL DIMENSIONS ARE IN INCHES UNLESS NOTED OTHERWISE

THE PERMANENT WAY CORPORATION

8109 TIS WELL DRIVE, #513, ALEXANDRIA, VIRGINIA 22306
 TEL: (703)619-1532 FAX: (703)619-1534 EMAIL: enr@pwaycorp.com

© 2001 This drawing has copyright which is owned by THE PERMANENT WAY CORPORATION (PWC) and may not be reproduced, in whole, in part, or in any form whatsoever without prior written authority from PWC. This drawing has been submitted on the understanding that it will not be used in any way against the interests of PWC.

HIAWATHA CORRIDOR LIGHT RAIL PROJECT
 MNDOT AGREEMENT NO. 80356
 RAILWORKS TRACK SYSTEMS INC.

TITLE
 TYPICAL ASSEMBLY
 LOW PROFILE LVT SUPPORTS WITH PANDROL FASTCLIP

A	FIRST ISSUE	ATB	BS	05/00
REV	REVISION	BY	APPY.	DATE

DRWN	CHKD	DATE	SCALE
ATB	BH	18 APRIL 2001	1/4
PLOT CODE	DRW No	SHEET	REV
1117,M4	MT/461/A67	1	A

EXHIBIT

SECTION A-A

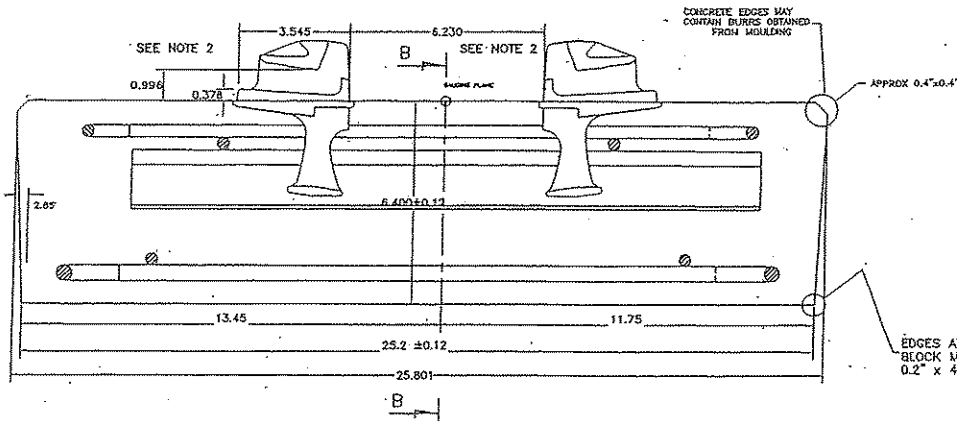

SECTION B-B

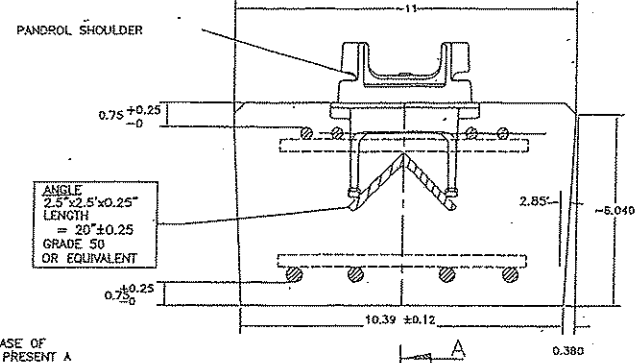

PLAN VIEW
HTS

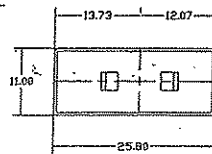

PARTIAL VIEW OF
SUPPORT BASE
SCALE 1/8

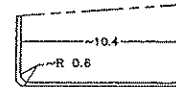

EACH LVT SUPPORT SHALL BE MARKED ON ITS TOP SURFACE AND IN A PERMANENT MANNER THE FOLLOWING:
- THE MANUFACTURER'S LOGO - IDENTIFICATION OF DATE -



WEIGHTS PER BLOCK:

CONCRETE ~ 150 lb
L PROFILE: ~ 6.8 lb
REINFORCEMENTS: ~ 9.3 lb
PANDROL SHOULDERS: ~ 6 lb
TOTAL WEIGHT: ~ 172 lb

Jan K. Kicha, P.E.
January 16, 2003

NOTES:

- 1) ALL DIMENSIONS ARE IN INCHES UNLESS NOTED OTHERWISE.
2) FASTENING DETAIL, SHOULDER TOLERANCE AND DIMENSIONS SHALL BE IN ACCORDANCE WITH PANDROL DRAWINGS AND SPECIFICATIONS.
3) THE RAIL SUPPORTS SHALL BE INSTALLED IN THE TRACK WITH AN INCLINATION EQUAL TO THE RAIL CANT.
4) THE LVT SUPPORT SHALL BE IN STRICT ACCORDANCE WITH THE TECHNICAL SPECIFICATION OF THE LVT SUPPORT.

MATERIAL SPECIFICATIONS

5) CONCRETE - 7000 psi 28 DAY COMPRESSIVE STRENGTH.

6) REINFORCEMENT BARS - GRADE 60 STEEL

- GENERAL SUPPORT CONFIGURATION IS BASED UPON:
- PANDROL FASTCLIP FASTENINGS
- 15 LB RAIL
- 8 1/2" GAUGE

URPORTS INSTALLED AT 1/40 CANT

I have applied for the registration in Minnesota and the application is pending.

LOWER ARMASON REINFORCEMENT SCALE 1/8

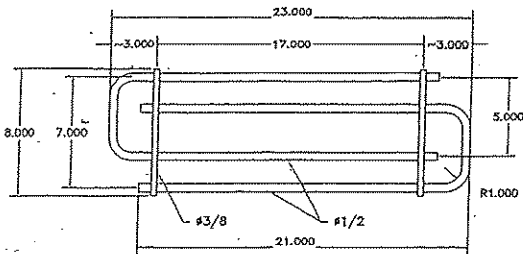

REINFORCEMENT TOTAL WEIGHT ~ 6.0 lb
#3/8" AND #1/2" DEFORMED REBAR

UPPER ARMASON REINFORCEMENT SCALE 1/8

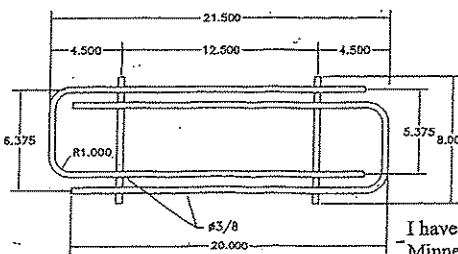

REINFORCEMENT TOTAL WEIGHT ~ 3.3 lb
#3/8" DEFORMED REBAR

THE PERMANENT WAY CORPORATION

8109 TIS WELL DRIVE, #513, ALEXANDRIA, VIRGINIA 22306
TEL: (703)819-1532 FAX: (703)819-1534 EMAIL: mail@perneway.com

© 2001 This drawing has copyright which is owned by THE PERMANENT WAY CORPORATION (PWC) and may not be reproduced, in whole, in part, or in any form whatsoever without prior written authority from PWC. This drawing has been submitted on the understanding that it will not be used in any way against the interests of PWC.

HIAWATHA CORRIDOR LIGHT RAIL PROJECT
MNDOT AGREEMENT NO. 80356
RAILWORKS TRACK SYSTEMS INC.

TITLE
LOW PROFILE LVT SUPPORTS
WITH PANDROL FASTCLIP

DRWN	CHKD	DATE	SCALE
ATB	BH	18 APRIL 2001	1/4
PLOT CODE	DRW No		SHEET
1117.M4	TR/495/A67		1
			REV
			A

REV	REVISION	BY	APPV.	DATE
A	FIRST ISSUE	ATB	BS	05/00

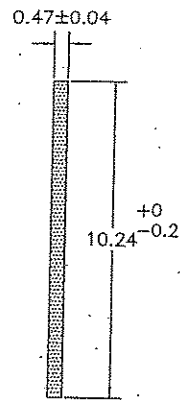
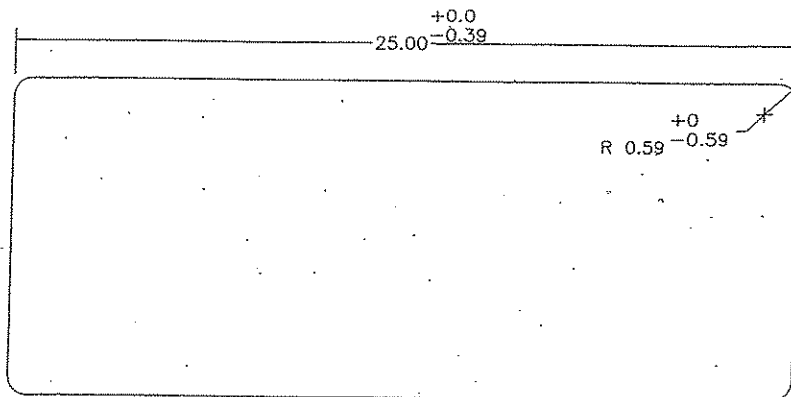

Accepted
 Accepted as Noted
 Rejected, Revise and Resubmit

Approval is only for general conformance with the design concept of the Project and the information given in the Contract Documents. Contractor is responsible for dimensions to be confirmed and correlated at the job site; information that pertains solely to the fabrication process or to the methods & methods of construction; coordination of the work of all trades and performing all work in a safe & satisfactory manner. This approval does not modify Contractor's duty to comply with the Contract Documents.

By: *[Signature]* Date: 01-31-03



Jan V. Ticha, P.E.
 January 16, 2003

NOTES: IDENTIFICATION MARKS ARE STAMPED ON THE PAD MATERIAL SHALL BE IN ACCORDANCE WITH THE TECHNICAL SPECIFICATION OF THE PAD.

I have applied for the registration in Minnesota and the application is pending.

ALL DIMENSIONS ARE IN INCHES UNLESS NOTED OTHERWISE

REV	REVISION	BY	APPV.	DATE
A	FIRST ISSUE	ATB	BS	05/00

THE PERMANENT WAY CORPORATION
 8109 TIS WELL DRIVE, #513, ALEXANDRIA, VIRGINIA 22308
 TEL: (703)819-1532 FAX: (703)819-1534 EMAIL: mtl@perway.com

© 2001 This drawing has copyright which is owned by THE PERMANENT WAY CORPORATION (PWC) and may not be reproduced, in whole, in part, or in any form whatsoever without prior written authority from PWC. This drawing has been submitted on the understanding that it will not be used in any way against the interests of PWC.

HIAWATHA CORRIDOR LIGHT RAIL PROJECT MNDOT AGREEMENT NO. 80356 RAILWORKS TRACK SYSTEMS INC.				
TITLE BLOCK PAD LOW PROFILE LVT SUPPORTS				
DRWN ATB	CHKO BH	DATE 18 APRIL 2001	SCALE 1/4.	
PLOT CODE 1117,M4	DRW No SM/452/A67	SHEET 1	REV A	

4 HIGH ON ORIGINAL

SECTION A-A

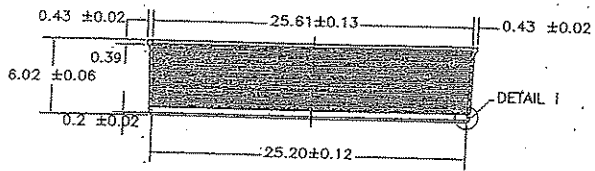

SECTION B-B

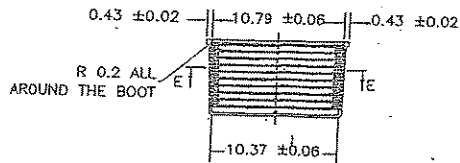

SECTION E-E
DETAIL OF RADII CONNECTING SIDE WALL
TO END WALL GROOVES.

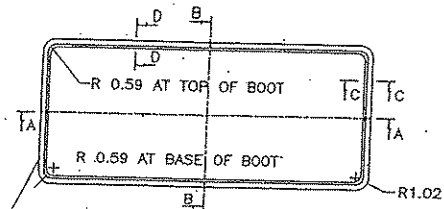
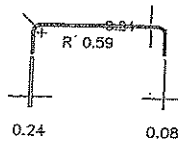

THE PART'S IDENTIFICATION MARKS ARE LOCATED ON THE TOP FLANGE OF THE BOOT
MARKS INCLUDE: MANUFACTURER REF., MOULD REF., DATE OF PRODUCTION

DETAIL J NTS

OPTIONAL DRAINAGE OPENINGS
ONE DRAINAGE OPENING CENTERED ON EACH END WALL OF THE BOOT.

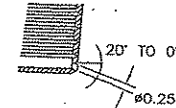

Jan H. Kisha, P.E.
January 16, 2003

I have applied for the registration in Minnesota and the application is pending.

MATERIAL SPECIFICATIONS

STYRENE BUTADIENE RUBBER (SBR)
70 - 80 SHORE A HARDNESS
ALL DIMENSIONS ARE IN INCHES UNLESS NOTED OTHERWISE

SECTION C-C
NTS

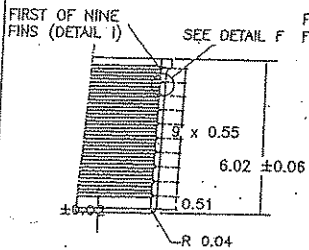

SECTION D-D
NTS

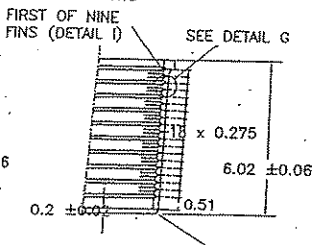

R 0.24 ALL AROUND THE BOOT

DETAIL F
NTS

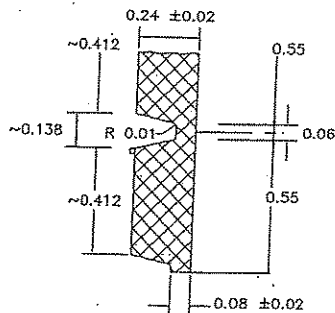

DETAIL G
NTS

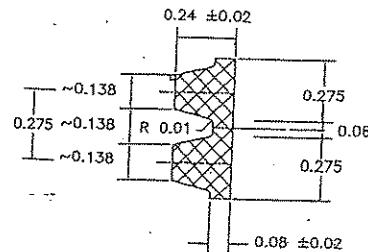

DETAIL I NTS

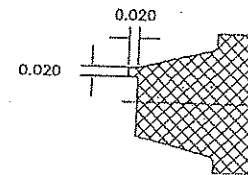

THE PERMANENT WAY CORPORATION

8109 TIS WELL DRIVE, #513, ALEXANDRIA, VIRGINIA 22306
TEL: (703)619-1532 FAX: (703)619-1534 EMAIL: mail@pwaycorp.com

© 2001 This drawing has copyright which is owned by THE PERMANENT WAY CORPORATION (PWC) and may not be reproduced, in whole, in part, or in any form whatsoever without prior written authority from PWC. This drawing has been submitted on the understanding that it will not be used in any way against the interests of PWC.

HIAWATHA CORRIDOR LIGHT RAIL PROJECT
MNDOT AGREEMENT NO. 80356
RAILWORKS TRACK SYSTEMS INC.

TITLE
RUBBER BOOT (TYPE HFR)
LOW PROFILE LVT SUPPORTS

REV	REVISION	BY	APPV.	DATE
A	FIRST ISSUE	ATB	BS	05/00

DRWN	CHKD	DATE	SCALE
ATB	BH	18 APRIL 2001	1/10
PLOT CODE	DRW No	SHEET	REV
1117,M10	CH/439/467		

Ben Barker

From: Creta King [creta.king@state.mn.us]
Sent: Thursday, August 28, 2003 8:14 AM
To: Ben Barker
Subject: FW: Answer to Complaint

-----Original Message-----

From: JanZicha@cs.com [mailto:JanZicha@cs.com]
Sent: Thursday, August 28, 2003 3:46 AM
To: creta.king@state.mn.us
Cc: mail@sonneville.com
Subject: Answer to Complaint

Dear Ms. King,

I have received a faxed copy of information on a complaint in Minnesota from Mr. Benjamin Baker. I do not have an e-mail address to answer him or the Board directly. Please pass to him this message.

I am currently working on several projects in China, Korea and Philippines. I do not have copies of stated drawings relevant to the Hiawatha project in Minnesota with me. I can send them after my return to the USA on September 12, 2003.

I have stamped mentioned drawings in the past and returned them to my client Permanent Way Corporation. I do not know what action was taken on this project after that. All I can say is that the LVT track supplied by PWC is the best choice available on the world market. It requires virtually no maintenance and has at least ten time longer life expectancy than anything else of the kind, as we have already found on LVT installation at twenty locations world-wide. There is no secret that not all of PWC's competitors like it. However, the proper place for improvement of their products is at the drafting board.

With Best Regards,

Jan H. Zicha, P.E.

EXHIBIT G