

STATE OF MINNESOTA
BOARD OF ARCHITECTURE, ENGINEERING, LAND SURVEYING,
LANDSCAPE ARCHITECTURE, GEOSCIENCE AND INTERIOR DESIGN

In the Matter of
Alan Kretman, Unlicensed

CEASE AND DESIST ORDER
AND
NOTICE OF RIGHT TO HEARING

Board File No: 2009-0002

TO: Mr. Alan Kretman
ProTerra Design Associates Inc.
11995 County Road 11 Suite 220
Burnsville, Minnesota 55337

ALLEGATIONS

The Complaint Committee of the Board of Architecture, Engineering, Land Surveying, Landscape Architecture, Geoscience and Interior Design ("Board") alleges as follows:

1. A complaint concerning Alan Kretman ("Respondent") has been received and reviewed by the Board's Complaint Committee.
2. Respondent was first licensed as a Landscape Architect in the State of Minnesota on September 24, 1981.
3. Respondent is currently licensed as a Landscape Architect by the Board. Respondent's Landscape Architect license expires on June 30, 2012.
4. Respondent is not currently and never has been licensed by the Board as a professional engineer in the State of Minnesota.
5. Respondent practiced professional engineering without a professional engineer license by signing civil engineering drawings for the 3R's Child Development Center and the Elm Creek

Trail Business Park, both located in Brooklyn Park, Minnesota. At the times relevant to the factual allegations herein, Respondent described himself as a Director of ProTerra Design Associates, Inc. ("PDA") and used this title when he corresponded with officials of the City of Brooklyn Park, Minnesota on behalf of PDA.

3R's Child Development Center

- a. On the C4.1 drawing dated April 1, 2008, Respondent, using his Landscape Architect license #15144, signed and certified a drawing for the 3R's Child Development Center, located in Brooklyn Park, Minnesota. A true and correct copy of this C4.1 drawing for the 3R's Child Development Center, located in Brooklyn Park, Minnesota, dated April 1, 2008 is attached as Exhibit A.
- b. On the C4.1 drawing (Exhibit A) Respondent, using his Landscape Architect's license #15144, signed and certified for the 3R's Child Development Center, located in Brooklyn Park, Minnesota, states: "PRELIMINARY FOR REVIEW ONLY." The C4.1 drawing could be used for construction by removing the "PRELIMINARY FOR REVIEW ONLY."
- c. On the C4.1 drawing (Exhibit A) Respondent, using his Landscape Architect's license #15144, signed and certified for the 3R's Child Development Center, located in Brooklyn Park, Minnesota, specified the sewer line with length, size, and slope. Specifying the sewer line with length, size, and slope, involves engineering analysis and design which is the practice of professional engineering as defined by Minnesota Statutes section 326.02, subdivision 3 (2010). Exhibit A contains

highlights of these five (5) areas on the C.4.1 drawing that are specific to the practice of professional engineering. They are labeled as 3.b.1 through 3.b.5:

3.b.1 250 LF 8" PVC, 0.40%

3.b.2 180 LF 8" PVC, 0.40%

3.b.3 430 LF

3.b.4 51 LF 8" PVC, 0.40%

3.b.5 35 LF 12" RCP.

- d. On the C6.1 drawing dated April 1, 2008, Respondent, using his Landscape Architect license #15144, signed and certified a drawing for the 3R's Child Development Center, located in Brooklyn Park, Minnesota. A true and correct copy of this C6.1 drawing for the 3R's Child Development Center, located in Brooklyn Park, Minnesota, dated April 1, 2008 is attached as Exhibit B.
- e. On the C6.1 drawing (Exhibit B) Respondent, using his Landscape Architect's license #15144, signed and certified for the 3R's Child Development Center, located in Brooklyn Park, Minnesota, specified the 'Storm Drain Bedding and Foundation', the 'Sanitary Sewer Manhole', and the 'Class 'B' Sanitary Sewer Pipe Bedding and Foundation'. The details in those three sections of the drawing are engineering specific. Respondent has provided specific design engineering information which is the practice of professional engineering as defined by Minnesota Statutes section 326.02, subdivision 3 (2010). Exhibit B contains highlights of these three (3) areas on the C.6.1 drawing that are specific to the practice of professional engineering. They are labeled as 4.a.1 through 4.a.3:

- 4.a.1 Storm Draining Bedding and Foundation
 - 4.a.2 Sanitary Sewer Manhole
 - 4.a.3 Class 'B' Sanitary Sewer Pipe Bedding and Foundation
- f. In a letter dated June 16, 2008 from Gary Brown, Director of Engineering and Building Inspections, City of Brooklyn Park, Minnesota, to the Respondent, Gary Brown stated: "Several of my staff members have been reviewing PDA's preliminary design of 3R's Child Development Center to be located on 85th Ave. N., east of city hall. On the front page (C0.1) of the Development Center plans (revised 4-01-08) there is no Civil Engineer listed even though the Landscape Architect and the Surveyor are listed as designers. Plan sheets C4.1 (Utility plan) and C6.1 & C6.2 (Civil Details) were signed by you as a Landscape Architect." A true and correct copy of the June 16, 2008 letter from Gary Brown, Director of Engineering and Building Inspections, City of Brooklyn Park, Minnesota, to the Respondent, is attached as Exhibit E.
- g. In a letter dated June 24, 2008 to Gary Brown, Director of Engineering and Building Inspections, City of Brooklyn Park, Minnesota, Respondent stated: "You have read the drawings correctly; there is no Civil Engineer on this project at this time. I have legally prepared all the drawings under my Landscape Architect's license from the State of Minnesota." A true and correct copy of the June 24, 2008 letter to Gary Brown, Director of Engineering and Building Inspections, City of Brooklyn Park, Minnesota, signed by Respondent, is attached as Exhibit F.

- h. In a letter dated January 8, 2009 from Gary Brown, Director of Engineering and Building Inspections, City of Brooklyn Park, Minnesota, Gary Brown stated:
- “The 3R’s application was for a CUP to allow construction of a 15,000 sq. ft. Day Care and all site improvements. Those plans were submitted for Planning approval and Mr. Kretman was advised that the building permit would not be issued until and unless a civil engineer submitted the plans with an approved signature and registration.” A true and correct copy of the letter dated January 8, 2009 from Gary Brown, Director of Engineering and Building Inspections, City of Brooklyn Park, Minnesota, is attached as Exhibit H.

Elm Creek Trail Business Park

- i. On the C4.1 drawing, dated July 11, 2008, Respondent, using his Landscape Architect license #15144, signed and certified a drawing for the Elm Creek Trail Business Park, located in Brooklyn Park, Minnesota. Specifying the materials on the C4.1 drawings, is the practice of professional engineering as defined by Minnesota Statutes section 326.02, subdivision 3 (2010). A true and correct copy of this C4.1 drawing for the Elm Creek Trail Business Park, located in Brooklyn Park, Minnesota, dated July 11, 2008 is attached as Exhibit C.
- j. On the C6.1 drawing, dated July 11, 2008, Respondent, using his Landscape Architect license #15144, signed and certified a drawing for the Elm Creek Trail Business Park, located in Brooklyn Park, Minnesota. A true and correct copy of this C6.1 drawing for the Elm Creek Trail Business Park, located in Brooklyn Park, Minnesota, dated July 11, 2008 is attached as Exhibit D.

k. On the C6.1 drawing (Exhibit D), dated July 11, 2008, Respondent, using his Landscape Architect license #15144, signed and certified a drawing for the Elm Creek Trail Business Park, located in Brooklyn Park, Minnesota, and specified the 'Storm Drain Bedding and Foundation', the 'Sanitary Sewer Manhole', and the 'Class 'B' Sanitary Sewer Pipe Bedding and Foundation'. The details in those three sections of the drawing are engineering specific. The Respondent has provided specific design engineering information which is the practice of professional engineering as defined by Minnesota Statutes section 326.02, subdivision 3 (2010). Exhibit D contains highlights of these three (3) areas on the C.6.1 drawing that are specific to the practice of professional engineering. They are labeled as 10.a.1 through 10.a.3:

10.a.1 Storm Draining Bedding and Foundation

10.a.2 Sanitary Sewer Manhole

10.a.3 Class 'B' Sanitary Sewer Pipe Bedding and Foundation

l. In a letter dated August 4, 2008 from Gary Brown, Director of Engineering and Building Inspections, City of Brooklyn Park, Minnesota, Gary Brown stated:
"Mr. Alan Kretman has recently (last week), submitted Preliminary Plans (dated June 11, 2008) for the Elm Creek Trail Business Park (enclosed). He has again signed these preliminary plans that a civil engineer should have prepared, sheets C4.1 Preliminary Utility Plan, sheets C6.1, C6.2, Civil Details, ..." A true and copy of the August 4, 2008 letter from Gary Brown, Director of Engineering and Building Inspections, City of Brooklyn Park, Minnesota, is attached as Exhibit G.

- m. In a letter dated January 8, 2009 from Gary Brown, Director of Engineering and Building Inspections, City of Brooklyn Park, Minnesota, Gary Brown stated: "On August 4, 2008, I submitted additional information regarding a second submittal that Mr. Kretman made to the City of Brooklyn Park regarding the Elm Creek Trail Business Park. In the case of the Elm Creek Trail Business Park preliminary plans, they were submitted for conceptual plan approval only. Those plans were recommended for approval by the City's Planning Commission even though they were inconsistent with the City's staging plan. On November 24, 2008, the City Council voted to deny the Elm Creek Trail Business Park concept plan." A true and correct copy of the letter dated January 8, 2009 from Gary Brown, Director of Engineering and Building Inspections, City of Brooklyn Park, Minnesota, is attached as Exhibit H.
- n. In this same letter dated January 8, 2009 (Exhibit H) from Gary Brown, Director of Engineering and Building Inspections, City of Brooklyn Park, Minnesota, Gary Brown stated: "I have also enclosed a recent complaint that the owners have filed against the City for denying the approval of the project. As you can see in the complaint on page 5, paragraph 14, indicates that the City refused to accept the submittal by Mr. Kretman because the information was incomplete....In paragraph 22, of the complaint, the City Council voted to deny the concept plan #08-123 for the following reasons:
1. The application is premature for the following reasons:
 - A. Roadway improvements are not in place or planned to serve the

type of development proposed.

- B. Brooklyn Park public utilities are not readily available to serve the site.
- C. There are currently approximately 400 acres of vacant land with City services available for office development.
- D. The current market does not warrant deviating from the staging plan without specific user identified.
- E. The Comprehensive Plan does not call for utilities to be staged into this area at this time.
- F. The zoning of the property does not allow for the development as proposed.
- G. The civil plans have not been designed by an engineer licensed in the State of Minnesota. "

6. The following order is in the public interest.

ORDER

NOW, THEREFORE, IT IS HEREBY ORDERED, pursuant to Minnesota Statutes section 326.111, subdivision 3 (2010), that Respondent Alan Kretman shall **CEASE AND DESIST** from practicing professional engineering in Minnesota until such time as he becomes licensed as a Professional Engineer in the State of Minnesota.

NOTICE OF RIGHT TO HEARING

Pursuant to Minnesota Statutes section 326.111, subdivision 3 (2010), Respondent may request a hearing in this matter. Such request must be in writing and served upon the Board within thirty days

after service of this Order, whereupon a hearing will be held within thirty days after receipt of the request unless Respondent and the Complaint Committee agree that the hearing be scheduled after the thirty-day period. In accordance with Minnesota Statutes section 326.111, subdivision 3 (2010), if no hearing is requested by Respondent within thirty days of service of this Order, this Order will become final and will remain in effect until it is modified or vacated by the Board.

In the event a hearing is scheduled in this matter, it will be held before an administrative law judge of the Office of Administrative Hearings for the State of Minnesota, 600 North Robert Street, Saint Paul, Minnesota, 55101, Telephone: (651) 361-7900. All parties have the right to represent themselves or be represented throughout the proceedings herein by legal counsel or a person of their choice if not otherwise prohibited as the unauthorized practice of law. The hearing will be conducted pursuant to the contested case procedures as prescribed in Minnesota Statutes section 14.57 (2010) to Minnesota Statutes section 14.69 (2010), as amended, and the Rules of the Office of Administrative Hearings, Minnesota Rules Chapter 1400.5010 through Minnesota Rules Chapter 1400.8401 (2009). FAILURE TO ATTEND THE HEARING IN THIS MATTER MAY RESULT IN THE ALLEGATIONS OF THIS ORDER BEING TAKEN AS TRUE AND DEEMED PROVED WITHOUT FURTHER EVIDENCE, THE PROCEEDING BEING DETERMINED AGAINST THE PARTY FAILING TO ATTEND. Questions concerning this Order may be directed to Assistant Attorney General Michele Owen, 1800 NCL Tower, 445 Minnesota Street, St. Paul, Minnesota 55101, Telephone: (651) 757-1322.

Copies of the above-cited statutes and procedural rules are available on-line at www.revisor.leg.state.mn.us or may be purchased from the Department of Administration, Public Documents Division, 117 University Avenue, St. Paul, Minnesota 55155, telephone: (651) 297-3000.

IF YOU NEED A REASONABLE ACCOMMODATION for a disability in order to participate in

the hearing process, such an accommodation can be made available upon advance request so that the hearing is accessible. Examples of reasonable accommodations include wheelchair accessibility, an interpreter, or Braille or large-print materials. If any party requires an interpreter, including a foreign language interpreter, the Board office must be promptly notified. To arrange an accommodation or an interpreter, you may contact Doreen Frost, Executive Director of the Board, Suite 160, 85 East Seventh Place, St. Paul, Minnesota 55101, or you may call: Voice (651) 296-2388 or TDD (651) 297-5353.

Dated: 10-16, 2010

STATE OF MINNESOTA
BOARD OF ARCHITECTURE,
ENGINEERING, LAND SURVEYING,
LANDSCAPE ARCHITECTURE,
GEOSCIENCE AND INTERIOR DESIGN

Billie Lawton
Billie Lawton, Public Member
Committee Chair

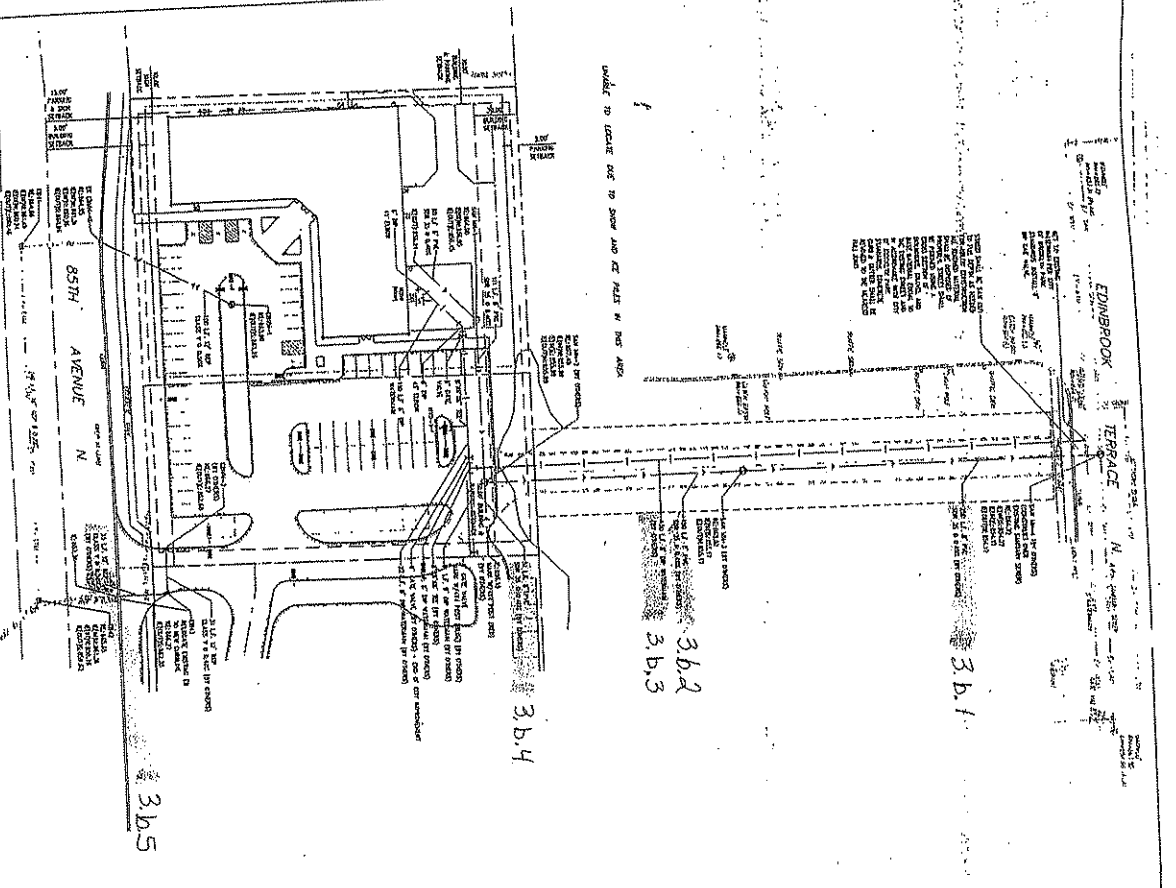

<p>1. ALL UTILITIES SHOWN ARE BASED ON RECORD DRAWINGS AND FIELD SURVEY DATA. THE CONTRACTOR SHALL VERIFY THE LOCATION AND DEPTH OF ALL UTILITIES PRIOR TO CONSTRUCTION.</p>
<p>2. THE CONTRACTOR SHALL BE RESPONSIBLE FOR OBTAINING ALL NECESSARY PERMITS AND APPROVALS FROM THE CITY OF BROOKLYN PARK AND THE MINNESOTA PUBLIC UTILITIES COMMISSION (MNUC) PRIOR TO CONSTRUCTION.</p>
<p>3. THE CONTRACTOR SHALL MAINTAIN ACCESS TO ALL ADJACENT PROPERTIES AND UTILITIES AT ALL TIMES. ANY OBSTRUCTIONS SHALL BE RESTORED TO ORIGINAL CONDITION OR BETTER.</p>
<p>4. ALL UTILITIES SHALL BE PROTECTED AND SUPPORTED AT ALL TIMES. ANY DAMAGE TO UTILITIES SHALL BE REPAIRED AT THE CONTRACTOR'S EXPENSE.</p>

GENERAL NOTES

1. ALL UTILITIES SHOWN ARE BASED ON RECORD DRAWINGS AND FIELD SURVEY DATA. THE CONTRACTOR SHALL VERIFY THE LOCATION AND DEPTH OF ALL UTILITIES PRIOR TO CONSTRUCTION.

2. THE CONTRACTOR SHALL BE RESPONSIBLE FOR OBTAINING ALL NECESSARY PERMITS AND APPROVALS FROM THE CITY OF BROOKLYN PARK AND THE MINNESOTA PUBLIC UTILITIES COMMISSION (MNUC) PRIOR TO CONSTRUCTION.

3. THE CONTRACTOR SHALL MAINTAIN ACCESS TO ALL ADJACENT PROPERTIES AND UTILITIES AT ALL TIMES. ANY OBSTRUCTIONS SHALL BE RESTORED TO ORIGINAL CONDITION OR BETTER.

4. ALL UTILITIES SHALL BE PROTECTED AND SUPPORTED AT ALL TIMES. ANY DAMAGE TO UTILITIES SHALL BE REPAIRED AT THE CONTRACTOR'S EXPENSE.

UTILITY NOTES

1. ALL UTILITIES SHALL BE PROTECTED AND SUPPORTED AT ALL TIMES. ANY DAMAGE TO UTILITIES SHALL BE REPAIRED AT THE CONTRACTOR'S EXPENSE.

2. THE CONTRACTOR SHALL BE RESPONSIBLE FOR OBTAINING ALL NECESSARY PERMITS AND APPROVALS FROM THE CITY OF BROOKLYN PARK AND THE MINNESOTA PUBLIC UTILITIES COMMISSION (MNUC) PRIOR TO CONSTRUCTION.

3. THE CONTRACTOR SHALL MAINTAIN ACCESS TO ALL ADJACENT PROPERTIES AND UTILITIES AT ALL TIMES. ANY OBSTRUCTIONS SHALL BE RESTORED TO ORIGINAL CONDITION OR BETTER.

4. ALL UTILITIES SHALL BE PROTECTED AND SUPPORTED AT ALL TIMES. ANY DAMAGE TO UTILITIES SHALL BE REPAIRED AT THE CONTRACTOR'S EXPENSE.

CONSTRUCTION SEQUENCE

1. EXCAVATE AND INSTALL MANHOLES AND UTILITY LINES.
2. INSTALL WATER MAIN AND SEWER MAINS.
3. INSTALL STORM SEWER MAINS.
4. INSTALL GAS MAINS.
5. INSTALL ELECTRIC MAINS.
6. INSTALL TELEPHONE MAINS.
7. INSTALL FIBER OPTIC MAINS.
8. INSTALL CABLE TV MAINS.
9. INSTALL SATELLITE TV MAINS.
10. INSTALL ALL OTHER UTILITIES.
11. BACKFILL AND RESTORE SURFACE.

MATERIALS

1. ALL MATERIALS SHALL BE APPROVED BY THE CITY OF BROOKLYN PARK AND THE MINNESOTA PUBLIC UTILITIES COMMISSION (MNUC) PRIOR TO CONSTRUCTION.

2. THE CONTRACTOR SHALL BE RESPONSIBLE FOR OBTAINING ALL NECESSARY PERMITS AND APPROVALS FROM THE CITY OF BROOKLYN PARK AND THE MINNESOTA PUBLIC UTILITIES COMMISSION (MNUC) PRIOR TO CONSTRUCTION.

3. THE CONTRACTOR SHALL MAINTAIN ACCESS TO ALL ADJACENT PROPERTIES AND UTILITIES AT ALL TIMES. ANY OBSTRUCTIONS SHALL BE RESTORED TO ORIGINAL CONDITION OR BETTER.

4. ALL UTILITIES SHALL BE PROTECTED AND SUPPORTED AT ALL TIMES. ANY DAMAGE TO UTILITIES SHALL BE REPAIRED AT THE CONTRACTOR'S EXPENSE.

LEGEND

SYMBOL	DESCRIPTION
(Symbol)	1. EXCAVATION
(Symbol)	2. WATER MAIN
(Symbol)	3. SEWER MAIN
(Symbol)	4. STORM SEWER MAIN
(Symbol)	5. GAS MAIN
(Symbol)	6. ELECTRIC MAIN
(Symbol)	7. TELEPHONE MAIN
(Symbol)	8. FIBER OPTIC MAIN
(Symbol)	9. CABLE TV MAIN
(Symbol)	10. SATELLITE TV MAIN
(Symbol)	11. MANHOLE
(Symbol)	12. UTILITY VALVE
(Symbol)	13. UTILITY BOX
(Symbol)	14. UTILITY CHASE
(Symbol)	15. UTILITY TRENCH
(Symbol)	16. UTILITY COVER
(Symbol)	17. UTILITY SIGN
(Symbol)	18. UTILITY MARKER
(Symbol)	19. UTILITY PROTECTIVE COVER
(Symbol)	20. UTILITY PROTECTIVE COVER
(Symbol)	21. UTILITY PROTECTIVE COVER
(Symbol)	22. UTILITY PROTECTIVE COVER
(Symbol)	23. UTILITY PROTECTIVE COVER
(Symbol)	24. UTILITY PROTECTIVE COVER
(Symbol)	25. UTILITY PROTECTIVE COVER
(Symbol)	26. UTILITY PROTECTIVE COVER
(Symbol)	27. UTILITY PROTECTIVE COVER
(Symbol)	28. UTILITY PROTECTIVE COVER
(Symbol)	29. UTILITY PROTECTIVE COVER
(Symbol)	30. UTILITY PROTECTIVE COVER

PRELIMINARY UTILITY PLAN

FOR REVIEW ONLY

3RD S CHILD DEVELOPMENT CENTER
 4900 85TH AVENUE NORTH
 BROOKLYN PARK, MINNESOTA
 PRELIMINARY UTILITY PLAN

DATE: 03/18/08
 DRAWN BY: AAK
 CHECKED BY: MJS

PDA
 PROFESSIONAL DESIGN AND DEVELOPMENT
 1100 DOUGLAS DRIVE
 CHAMPLAIN, MN 55316
 PH: 763.323.1727
 FAX: 763.323.2997

DINGMAN CONSTRUCTION & DEVELOPMENT
 1100 DOUGLAS DRIVE
 CHAMPLAIN, MN 55316
 PH: 763.323.1727
 FX: 763.323.2997

EXHIBIT A

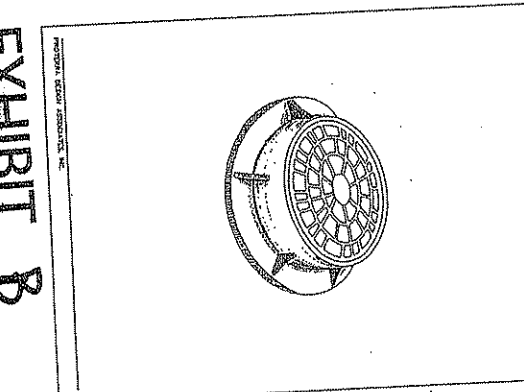
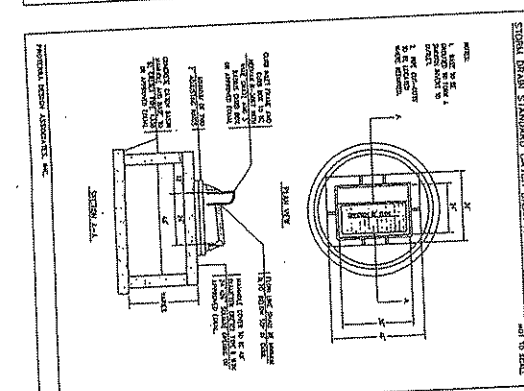
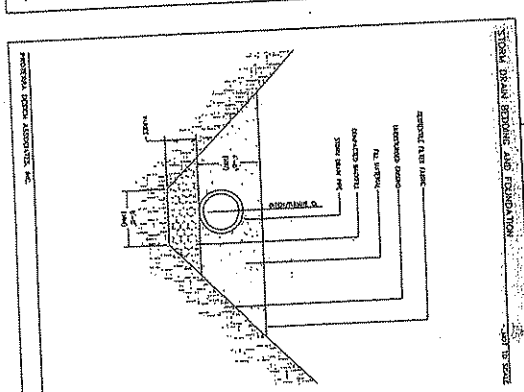
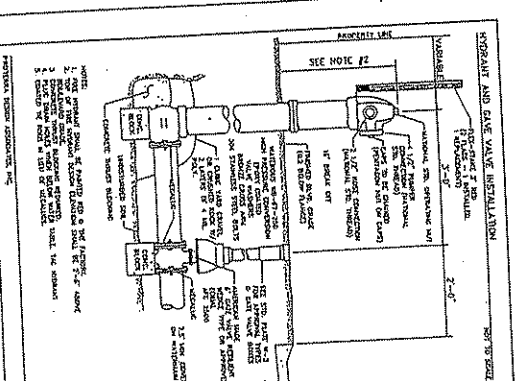
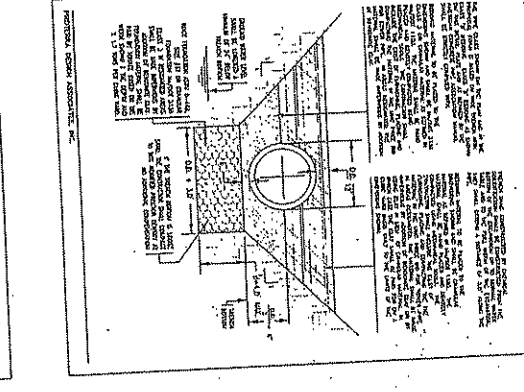
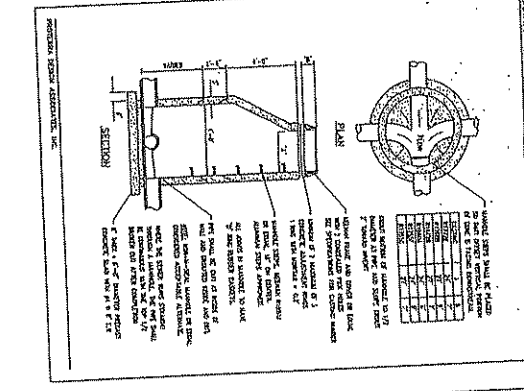
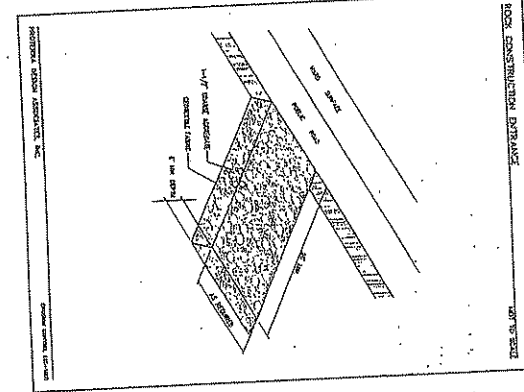
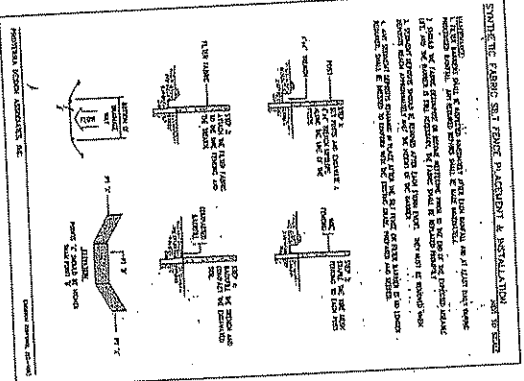

4a.1

4a.2

4a.3

EXHIBIT B

Project Name and Address	3R'S CHILD DEVELOPMENT CENTER 4950 85TH AVENUE NORTH BROOKLYN PARK, MINNESOTA
Client	DAK
Drawn By	DAK
Checked By	DAK
Date	03/14/85

CIVIL DETAILS

NO.	DATE	DESCRIPTION

PDA
 PROFESSIONAL DESIGN ASSOCIATES, INC.
 1100 HOBSON BLVD., SUITE 110
 COOK COUNTY, ILL. 60086
 TEL: 708.233.7200
 FAX: 708.233.7201

McAuliffe
 CIVIL ENGINEER
 1100 HOBSON BLVD., SUITE 110
 COOK COUNTY, ILL. 60086
 TEL: 708.233.7200
 FAX: 708.233.7201

DINGMAN CONSTRUCTION & DEVELOPMENT
 11030 DOUGLAS DRIVE
 CHAMPLIN, MN 55316
 TEL: 763.323.1727
 FX: 763.323.2997

PROPOSED DATE

SYNTHETIC FABRIC SILT FENCE PLACEMENT & INSTALLATION NOT TO SCALE

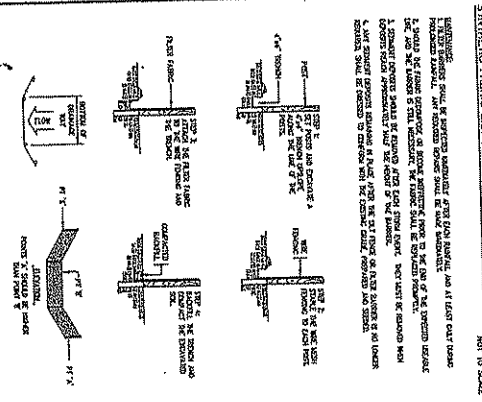

ROCK CONSTRUCTION ENTRANCE NOT TO SCALE

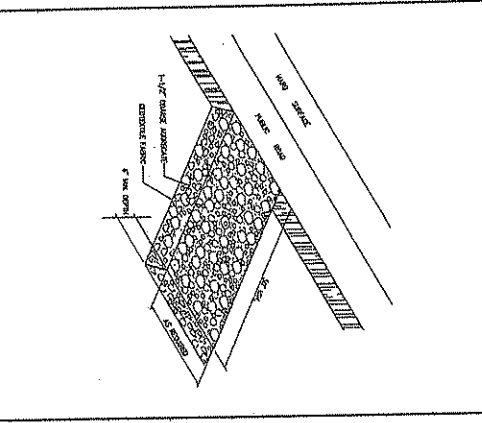

STAINLESS STEEL MANHOLE NOT TO SCALE

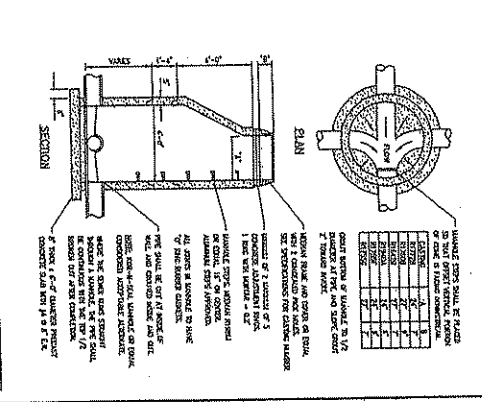

CLASS 'B' SANITARY SEWER PIPE BEDDING AND FOUNDATION NOT TO SCALE

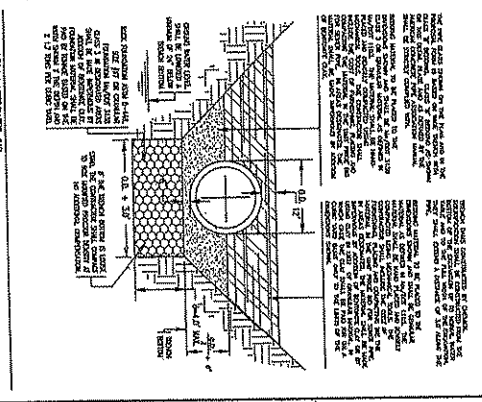

HYPERTIGHT AND GIVE VALVE INSTALLATION NOT TO SCALE

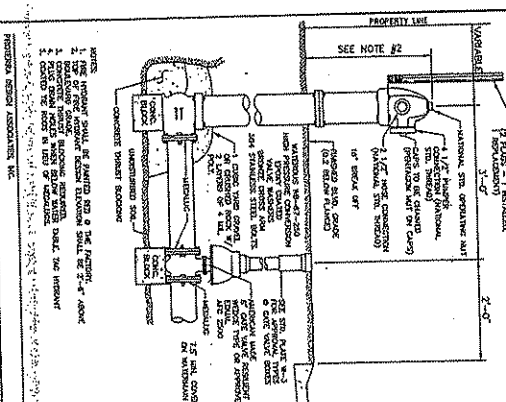

STORM DRAIN BEDDING AND FOUNDATION NOT TO SCALE

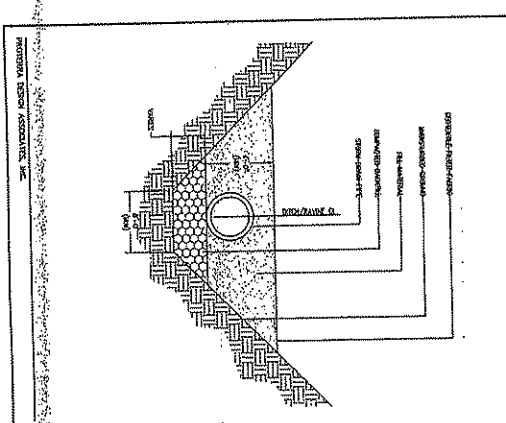

STORM DRAIN STANDARD CATCH BASIN MANHOLE NOT TO SCALE

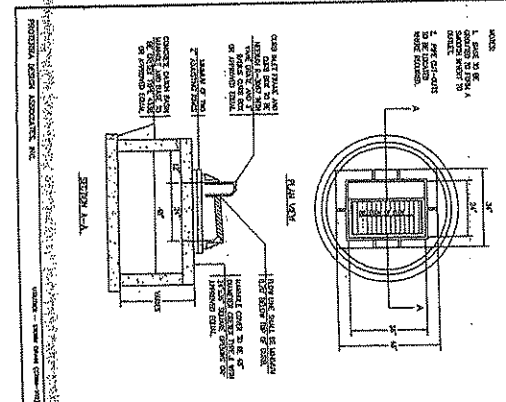

REBAR R-2878 FRAME WITH CONVEX GRATE NOT TO SCALE

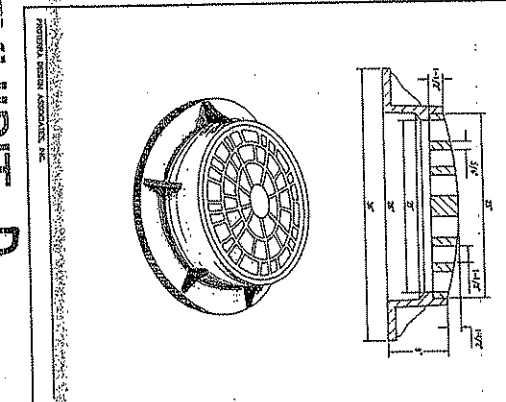

EXHIBIT D



RECEIVED
JUN 18 2008



5200 85th Ave. N., Brooklyn Park, MN 55443-4301 • Phone 763-424-8000 • Fax 763-493-8391
TDD: 763-493-8392

Gary E. Brown, P.E.
Director of Engineering & Building Inspections

June 16, 2008

Alan Kretman
Proterra Design Associates
7200 Hudson Blvd.
Suite 110
Oakdale, MN 55128

Dear Alan:

Several of my staff members have been reviewing PDA's preliminary design of 3R'S Child Development Center to be located on 85th Ave. N., east of city hall. On the front page (C0.1) of the Development Center plans (revised 4-01-08) there is no Civil Engineer listed even though the Landscape Architect and the Surveyor are listed as designers. Plan sheets C4.1 (Utility plan) and C6.1 & C6.2 (Civil Details) were signed by you as a Landscape Architect. Furthermore, plan sheet C5.1 (Preliminary Plat) was also signed by you even though I am assuming that Greg Prasch of Lot Surveys performed the work.

As you know, signing plans that were not prepared by you is a violation of state statute 326.03 LICENSE OR CERTIFICATE REQUIRED, Subdivision 1. By no later than June 23, 2008, please submit new drawings to the city of Brooklyn Park with the above referenced pages signed by the parties that have actually prepared the documents and provide the city with the name of the civil engineer who is responsible for the design. That person should be listed along with the other designers on plan sheet C0.1.

Sincerely

Gary E. Brown P. E.
Director of Engineering and Building Inspections

Cindy Sherman, Director of Planning, City of Brooklyn Park
Dale Dingman, Dingman Constr. & Dev., 11030 Douglass Dr., Champlin MN 55316
Jason Letourneau, Letourneau Design Assoc., 8001 5th St., Spring Lake Park, MN 55432
Greg Prasch, Lot Surveys Co. Inc., 7601 73rd Ave. N., Brooklyn Park, MN 55428
Doreen Frost, Executive Director of Board of Architecture, Engineering, Land Surveying,
Landscape Architecture, Geoscience & Interior Design, 85 E. 7th Place, Suite 160, St. Paul, MN
55101-2113
Enclosed: Plan sheets C0.1, C4.1, C5.1, C6.1, & C6.2

www.brooklynpark.org

EXHIBIT E
Pg. 1

3R'S CHILD DEVELOPMENT CENTER

BROOKLYN PARK, MINNESOTA

EDWARDS BL AVENUE N

DRAWING INDEX

201	GENERAL NOTES
202	AS APPEARING ON THIS DRAWING
203	GENERAL NOTES
204	GENERAL NOTES
205	GENERAL NOTES
206	GENERAL NOTES
207	GENERAL NOTES
208	GENERAL NOTES
209	GENERAL NOTES
210	GENERAL NOTES
211	GENERAL NOTES
212	GENERAL NOTES
213	GENERAL NOTES
214	GENERAL NOTES
215	GENERAL NOTES
216	GENERAL NOTES
217	GENERAL NOTES
218	GENERAL NOTES
219	GENERAL NOTES
220	GENERAL NOTES

CITY
 CITY OF BROOKLYN PARK
 10000 AVENUE NORTH
 BROOKLYN PARK, MN 55428
 PHONE: (763) 433-1122

OWNER/DEVELOPER
 3R'S CHILD DEVELOPMENT CENTER
 1100 DOUGLAS DRIVE
 CHAMBLAIN, MN 55316
 PHONE: (763) 523-1122

DAYCARE/SCHOOL
 3R'S CHILD DEVELOPMENT CENTER
 1100 DOUGLAS DRIVE
 CHAMBLAIN, MN 55316
 PHONE: (763) 523-1122

LANDSCAPE ARCHITECT
 LANDSCAPE ARCHITECT
 1100 DOUGLAS DRIVE
 CHAMBLAIN, MN 55316
 PHONE: (763) 523-1122

SURVEYOR
 SURVEYOR
 1100 DOUGLAS DRIVE
 CHAMBLAIN, MN 55316
 PHONE: (763) 523-1122

LEGAL DESCRIPTION
 LEGAL DESCRIPTION
 1100 DOUGLAS DRIVE
 CHAMBLAIN, MN 55316
 PHONE: (763) 523-1122

DATE OF DRAWING
 DATE OF DRAWING
 1100 DOUGLAS DRIVE
 CHAMBLAIN, MN 55316
 PHONE: (763) 523-1122

PROJECT NO.
 PROJECT NO.
 1100 DOUGLAS DRIVE
 CHAMBLAIN, MN 55316
 PHONE: (763) 523-1122

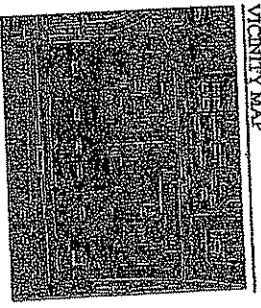
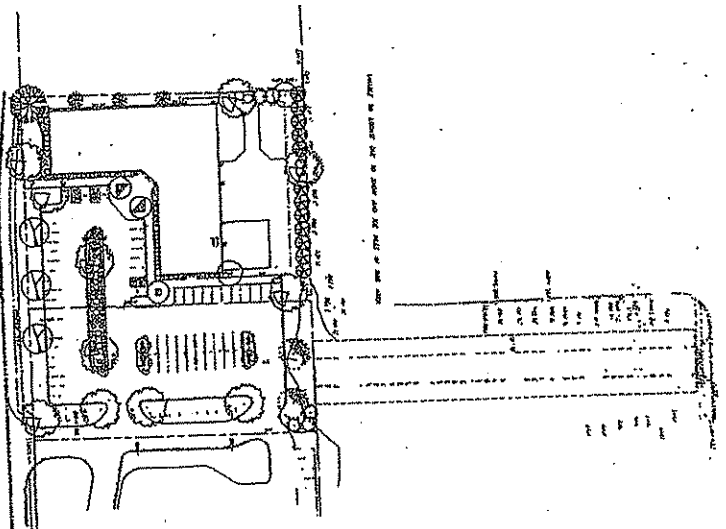

LEGEND

EXISTING		PROPOSED	
1	EXISTING BUILDING	1	PROPOSED BUILDING
2	EXISTING DRIVEWAY	2	PROPOSED DRIVEWAY
3	EXISTING SIDEWALK	3	PROPOSED SIDEWALK
4	EXISTING PAVEMENT	4	PROPOSED PAVEMENT
5	EXISTING CURB	5	PROPOSED CURB
6	EXISTING UTILITY	6	PROPOSED UTILITY
7	EXISTING LANDSCAPE	7	PROPOSED LANDSCAPE
8	EXISTING TREES	8	PROPOSED TREES
9	EXISTING FENCES	9	PROPOSED FENCES
10	EXISTING SIGNAGE	10	PROPOSED SIGNAGE
11	EXISTING LIGHTING	11	PROPOSED LIGHTING
12	EXISTING UTILITIES	12	PROPOSED UTILITIES
13	EXISTING EROSION CONTROL	13	PROPOSED EROSION CONTROL
14	EXISTING DRAINAGE	14	PROPOSED DRAINAGE
15	EXISTING ACCESS	15	PROPOSED ACCESS
16	EXISTING UTILITIES	16	PROPOSED UTILITIES
17	EXISTING UTILITIES	17	PROPOSED UTILITIES
18	EXISTING UTILITIES	18	PROPOSED UTILITIES
19	EXISTING UTILITIES	19	PROPOSED UTILITIES
20	EXISTING UTILITIES	20	PROPOSED UTILITIES

EXHIBIT E, Pg. 2

COVER SHEET

PROJECT NO.	0001
SHEET NO.	001
TITLE	3R'S CHILD DEVELOPMENT CENTER
DATE	01/10/00
SCALE	AS SHOWN
DESIGNER	3R'S CHILD DEVELOPMENT CENTER
DATE	01/10/00
SCALE	AS SHOWN
DESIGNER	3R'S CHILD DEVELOPMENT CENTER

3R'S CHILD DEVELOPMENT CENTER
 1100 DOUGLAS DRIVE
 CHAMBLAIN, MN 55316
 PHONE: (763) 523-1122

REVISIONS

NO.	DATE	DESCRIPTION
1	01/10/00	ISSUED FOR PERMIT
2	01/10/00	ISSUED FOR PERMIT
3	01/10/00	ISSUED FOR PERMIT
4	01/10/00	ISSUED FOR PERMIT
5	01/10/00	ISSUED FOR PERMIT
6	01/10/00	ISSUED FOR PERMIT
7	01/10/00	ISSUED FOR PERMIT
8	01/10/00	ISSUED FOR PERMIT
9	01/10/00	ISSUED FOR PERMIT
10	01/10/00	ISSUED FOR PERMIT

PDA
 PROFESSIONAL DESIGN ASSOCIATES
 1100 DOUGLAS DRIVE
 CHAMBLAIN, MN 55316
 PHONE: (763) 523-1122

Mr. Edwards
 1100 DOUGLAS DRIVE
 CHAMBLAIN, MN 55316
 PHONE: (763) 523-1122

DINGMAN CONSTRUCTION & DEVELOPMENT
 1100 DOUGLAS DRIVE
 CHAMBLAIN, MN 55316
 PHONE: (763) 523-1122
 FAX: (763) 523-2597

1/10/00

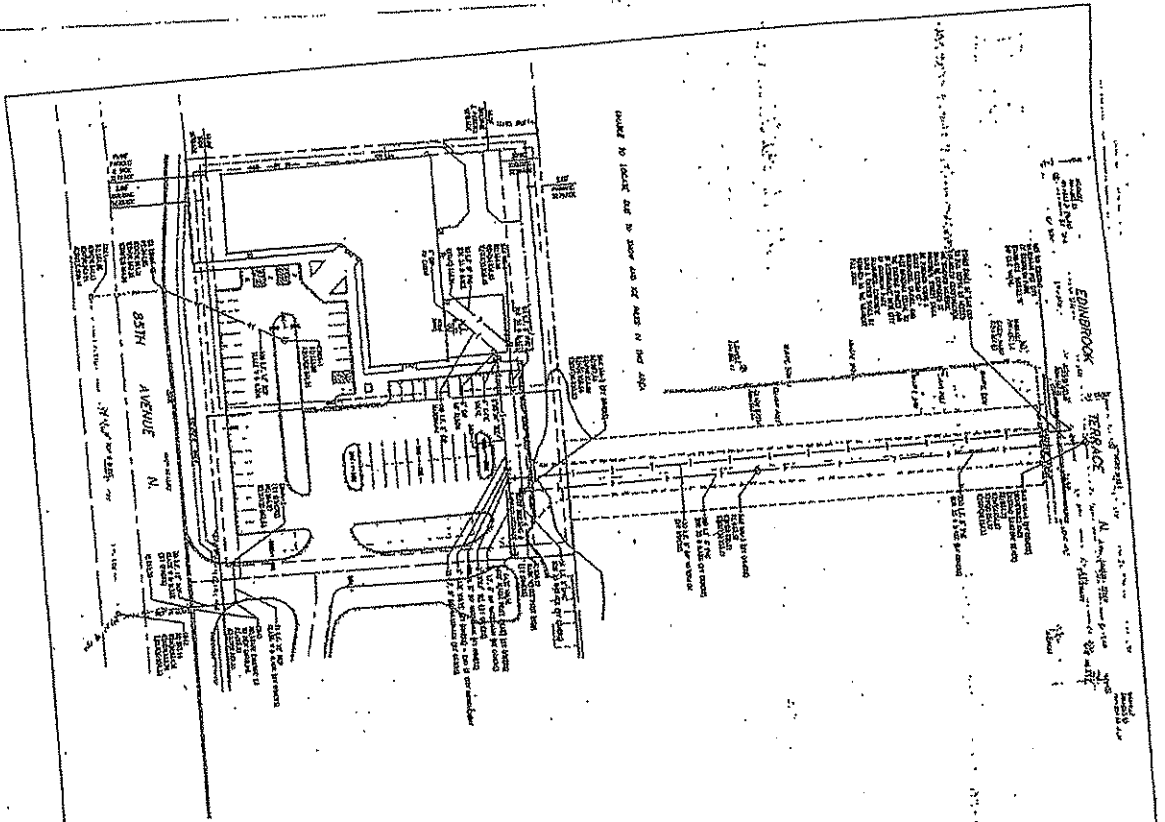

1. ALL UTILITIES SHOWN ARE BASED ON RECORD DRAWINGS AND FIELD SURVEY. THE CONTRACTOR SHALL VERIFY THE LOCATION AND DEPTH OF ALL UTILITIES PRIOR TO CONSTRUCTION.
2. ALL UTILITIES SHALL BE DEEPENED TO A MINIMUM OF 48\"/>

GENERAL NOTES

1. THE CONTRACTOR SHALL BE RESPONSIBLE FOR OBTAINING ALL NECESSARY PERMITS FROM THE CITY OF BROOKLYN PARK AND THE STATE OF MINNESOTA. THE CONTRACTOR SHALL ALSO BE RESPONSIBLE FOR OBTAINING ALL NECESSARY PERMITS FROM THE UTILITIES COMPANIES.

2. ALL UTILITIES SHALL BE DEEPENED TO A MINIMUM OF 48\"/>

UTILITY NOTES

1. ALL UTILITIES SHOWN ARE BASED ON RECORD DRAWINGS AND FIELD SURVEY. THE CONTRACTOR SHALL VERIFY THE LOCATION AND DEPTH OF ALL UTILITIES PRIOR TO CONSTRUCTION.

2. ALL UTILITIES SHALL BE DEEPENED TO A MINIMUM OF 48\"/>

MATERIALS

1. ALL MATERIALS SHALL BE OF THE BEST QUALITY AND SHALL BE APPROVED BY THE CITY ENGINEER PRIOR TO INSTALLATION.

2. ALL MATERIALS SHALL BE STORED ON-SITE AND PROTECTED FROM WEATHER AND DAMAGE.

CONSTRUCTION REQUIREMENTS

1. ALL CONSTRUCTION SHALL BE IN ACCORDANCE WITH THE CITY OF BROOKLYN PARK SPECIFICATIONS AND STANDARDS.

2. ALL CONSTRUCTION SHALL BE COMPLETED WITHIN THE SPECIFIED TIME FRAME.

3. ALL CONSTRUCTION SHALL BE MAINTAINED AT ALL TIMES.

LEGEND

SYMBOL	DESCRIPTION
○	Manhole
□	Valve
—	Water Main
- - -	Sewer Main
—	Gas Main
—	Electric Main
—	Telephone Main
—	Cable TV Main
—	Storm Sewer
—	Proposed Utility

PRELIMINARY
FOR REVIEW ONLY

3R'S CHILD
DEVELOPMENT CENTER
4700 83TH AVENUE NORTH
BROOKLYN PARK, MINNESOTA
PRELIMINARY UTILITY PLAN

DATE: 01/18/18
DRAWN BY: JAK
CHECKED BY: JAK
SCALE: AS SHOWN



DINGMAN
CONSTRUCTION &
DEVELOPMENT
1188 DOUGLAS DRIVE
CHAMPLIN, MN 55316
TEL: 763.322.1727
FAX: 763.322.0977

EXHIBIT E, Pg. 3

PRELIMINARY PLAT FOR
GENORE ADDITION

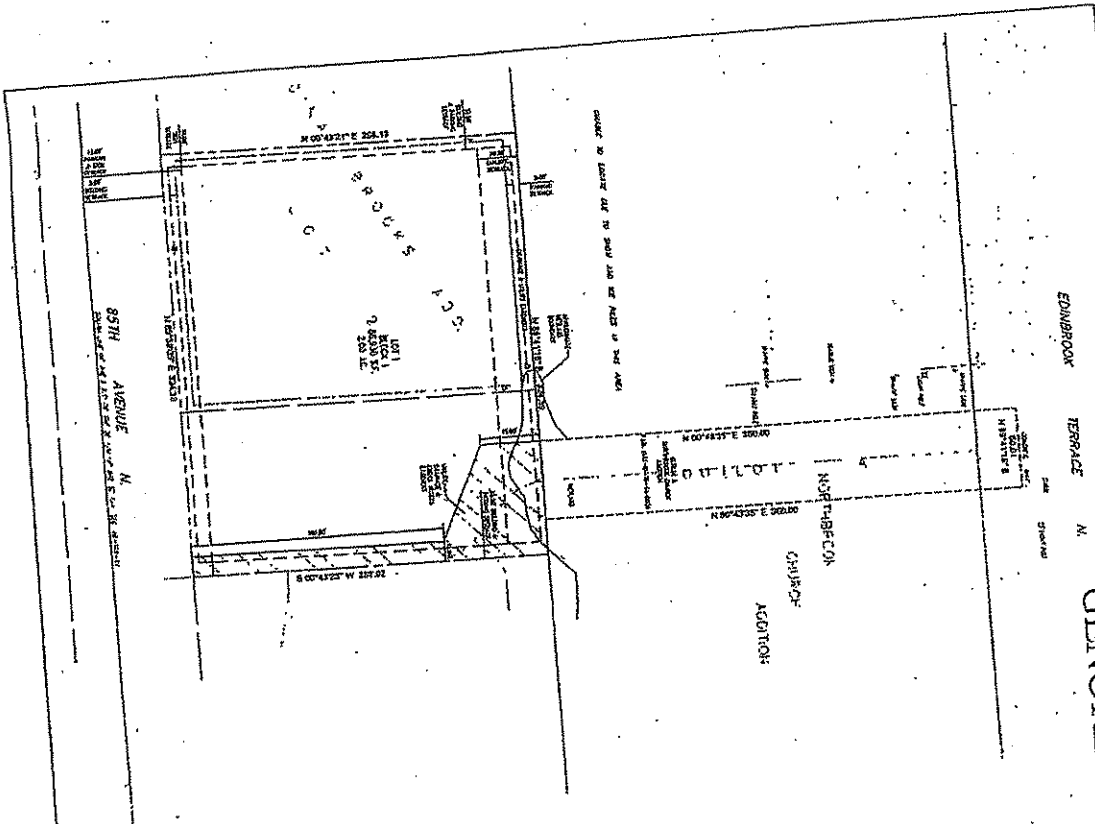

GENERAL NOTES

1. THIS PLAT IS A PRELIMINARY PLAT AND IS SUBJECT TO THE REVIEW AND APPROVAL OF THE CITY OF MINNEAPOLIS.
2. THE PLAT IS BASED ON THE SURVEY OF THE PROPERTY BY THE SURVEYOR, AND THE SURVEYOR IS NOT RESPONSIBLE FOR THE ACCURACY OF THE INFORMATION PROVIDED HEREON.
3. THE PLAT IS SUBJECT TO THE CITY OF MINNEAPOLIS ZONING ORDINANCES AND THE CITY ENGINEER'S REVIEW.
4. THE PLAT IS SUBJECT TO THE CITY OF MINNEAPOLIS PLAT ACT AND THE CITY ENGINEER'S REVIEW.
5. THE PLAT IS SUBJECT TO THE CITY OF MINNEAPOLIS PLAT ACT AND THE CITY ENGINEER'S REVIEW.
6. THE PLAT IS SUBJECT TO THE CITY OF MINNEAPOLIS PLAT ACT AND THE CITY ENGINEER'S REVIEW.
7. THE PLAT IS SUBJECT TO THE CITY OF MINNEAPOLIS PLAT ACT AND THE CITY ENGINEER'S REVIEW.
8. THE PLAT IS SUBJECT TO THE CITY OF MINNEAPOLIS PLAT ACT AND THE CITY ENGINEER'S REVIEW.
9. THE PLAT IS SUBJECT TO THE CITY OF MINNEAPOLIS PLAT ACT AND THE CITY ENGINEER'S REVIEW.
10. THE PLAT IS SUBJECT TO THE CITY OF MINNEAPOLIS PLAT ACT AND THE CITY ENGINEER'S REVIEW.

SITE DATA

Area	1.25
Volume	1.25
Weight	1.25
Height	1.25
Length	1.25
Width	1.25
Depth	1.25
Area	1.25
Volume	1.25
Weight	1.25
Height	1.25
Length	1.25
Width	1.25
Depth	1.25

OWNER/DEVELOPER
3R'S CHILD DEVELOPMENT CENTER
4900 85TH AVENUE NORTH
55505
MINNEAPOLIS, MN 55412

ARCHITECT
PDA
1100 DOUGLAS DRIVE
CHAMPLAIN, MN 55316
PH: 763.323.1277
FX: 763.323.2597

LANDSCAPE ARCHITECT
PDA
1100 DOUGLAS DRIVE
CHAMPLAIN, MN 55316
PH: 763.323.1277
FX: 763.323.2597

ENGINEER
PDA
1100 DOUGLAS DRIVE
CHAMPLAIN, MN 55316
PH: 763.323.1277
FX: 763.323.2597

LEGAL DESCRIPTION
LOT 1, BLOCK 1, GENORE ADDITION, CITY OF MINNEAPOLIS, STATE OF MINNESOTA.

PRELIMINARY FOR REVIEW ONLY

3R'S CHILD DEVELOPMENT CENTER
4900 85TH AVENUE NORTH
55505
MINNEAPOLIS, MN 55412
PRELIMINARY PLAT

DATE: 03/14/88
BY: MAX

EXHIBIT E, P.4

EXHIBIT E, P.5

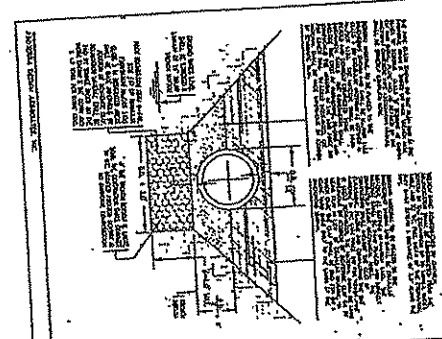
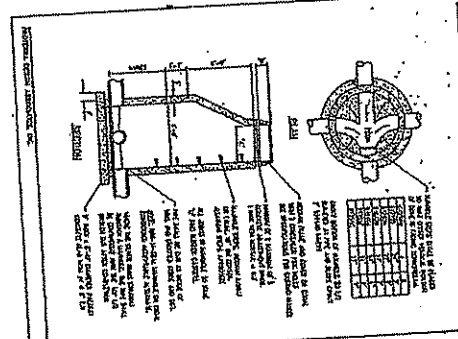
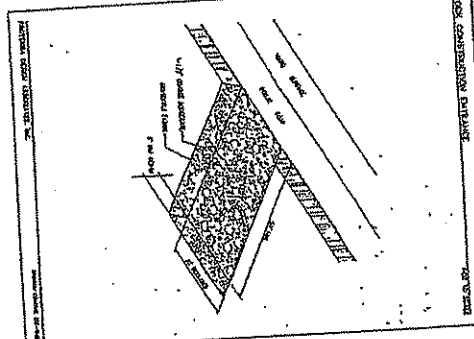
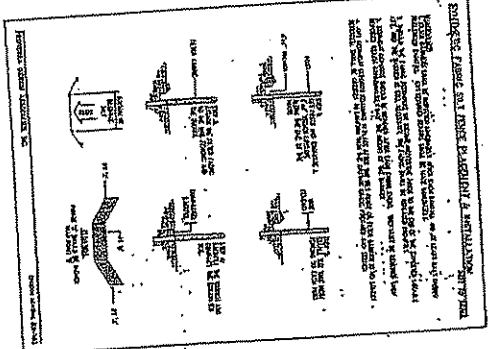
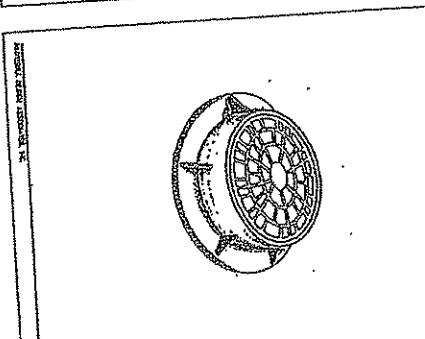
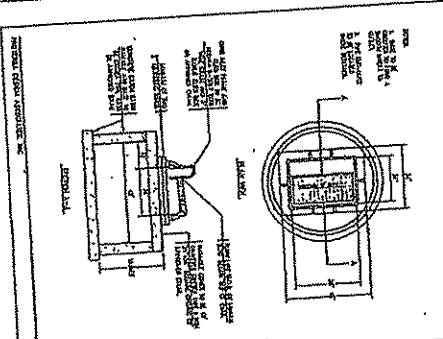
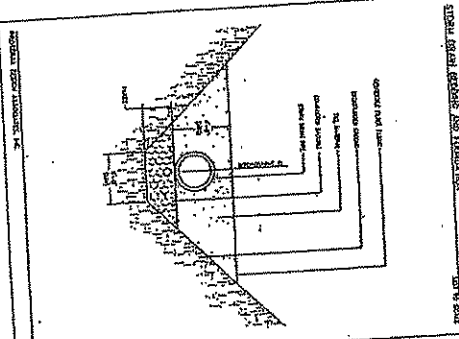
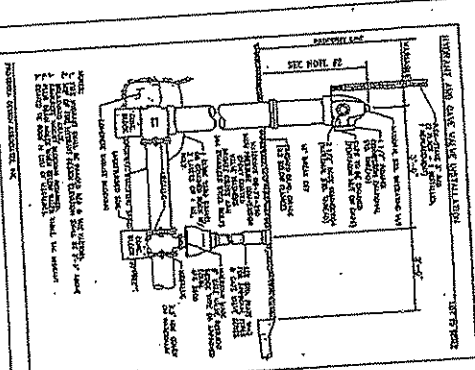

PROJECT NO.	000000
DATE	03/14/02
DRAWN BY	LAN
CHECKED BY	CS.1

3R'S CHILD DEVELOPMENT CENTER
 4900 58TH AVENUE NORTH
 BROOKLYN PARK, MINNESOTA

CIVIL DETAILS

PDA

PROFESSIONAL DESIGN ASSOCIATES

1000 WASHINGTON AVENUE, SUITE 100
 MINNEAPOLIS, MN 55402

TEL: 612.338.2200
 FAX: 612.338.2201

DINGMAN CONSTRUCTION & DEVELOPMENT

1100 DUGLAS DRIVE
 CHAMPLAIN, MN 55316
 PH: 763.523.2727
 FX: 763.523.2597

NOT TO SCALE



June 24, 2008

Gary E. Brown, PE
City of Brooklyn Park
5200 85th Avenue North
Brooklyn Park, MN 55443

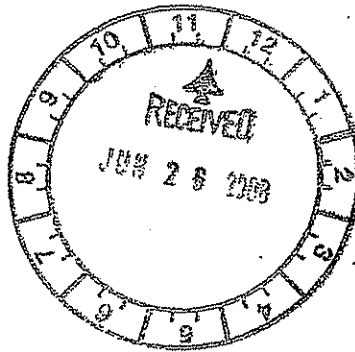

PLANNING
CIVIL ENGINEERING
PROJECT MANAGEMENT
LANDSCAPE ARCHITECTURE

RE: 3R's Child Development Center -- 85th Avenue North, Brooklyn Park, MN
PDA Comm. 08006

Dear Gary,

Thank you for sending your letter of June 16, 2008, to me regarding this project. I have always respected your opinion and expertise in regards to civil engineering for the City of Brooklyn Park.

I also have respected the MN State Board of AELSLAGID over the years by calling them on a consistent basis whenever I was concerned about potential interpretation issues in the State Statutes. That is why Doreen and I know each other. I have called frequently enough to establish this fact. Because I have taken a very conscientious position and called the Board whenever I had an interpretation question, Doreen has also suggested to me that I apply to be considered for appointment to the State Board. She knows that I want to make sure that I and others are doing everything correctly.

You have read the drawings correctly, there is no Civil Engineer on this project at this time. I have legally prepared all of the drawings under my Landscape Architect's license from the State of Minnesota. Therefore, I am not in violation of MN State Statute 326.03 LICENSE OR CERTIFICATE REQUIRED. We will not be resubmitting the drawings at this time because we just received the Geotechnical Report and are updating the drawings to include that background information.

I am basing my ability to do all of the drawings that I completed on a specific conversation that I had in the spring of 2001 at the state capitol with Doreen Frost, Executive Director of the State Board and with State Board members Robert Smith and the late Greg Kopischke. We were there for a ceremony for new licensees. An employee of mine who worked under me as an EIT had passed his PE exam and I was there to show my support for him.

Doreen, Bob, Greg and I discussed the practice of Landscape Architecture and the type of work that RLA's are allowed to do in the State of Minnesota. The three of them were in concurrence and specifically stated that I could do the type of work that I am doing now. That is when I started broadening the scope of design work that I do. They cited a portion of MN State Statute 326.02 LICENSURE OR CERTIFICATION, Subd.4 Practice of Landscape Architecture, which states the following:

"Any person shall be deemed to be practicing landscape architecture, within the meaning of sections 326.02 to 326.15, who holds out as being able to perform or who does perform any professional service in connection with the development of land

7200 Hudson Blvd. Suite 110 OAKDALE, MINNESOTA 55128
PHONE (651) 739-8131 FAX (651) 739-0846
www.proterradesign.com

EXHIBIT F,

Pg. 1

Page 2

June 23, 2008

Gary E. Brown, PE - City of Brooklyn Park

RE: 3R's Child Development Center - 85th Avenue North, Brooklyn Park, MN
PDA Comm. 08006

areas where the dominant purpose of the service is the preservation, enhancement or determination of proper land uses, natural land features, ground cover and planting, naturalistic and aesthetic values, the settings, approaches or environment for structures or other improvements, and the consideration and determination of inherent problems of the land relating to erosion, wear and tear, blight and hazards. *This practice shall include the location and arrangement of tangible objects and features incidental and necessary to the purposes outlined* (emphasis added) but shall not include the design of structures or facilities with separate and self-contained purposes as ordinarily included in the practice of engineering or architecture or the preparation of boundary surveys or final land plats, as ordinarily included in the practice of land surveying".

The premise for their position was that utilities are "*tangible objects and features incidental and necessary to the purposes outlined.*" As for signing preliminary plats, I have been doing this for a long time. The practice at all of the engineering firms that I have worked at throughout my career has been that either Landscape Architects or Civil Engineers can sign a preliminary plat, but not surveys or final plats, which is specifically excluded in MN State Statute 326.02, Subd.4.

Doreen also stated to me that if any public official or design professional questioned these interpretations, that she would assist me in clarifying what is allowed under state statutes. She has also told me that City Engineers have the right to state their own position on this interpretation issue. That is why I have respected your position in a professional manner, promised you and will follow through with turning over the portion of the work that you would like to have done by a PE for completion of our Construction Documents.

I also appreciate your comment that I should have gotten the interpretation issued documented in writing. I am hoping with your support we can have the State Board clarify this so that this type of issue will not happen again. As always, I will follow the guidance of the State Board on this issue.

Again, I want to thank you for putting your concerns in writing and addressing this in a professional manner. It was enjoyable talking with you.

Sincerely,
ProTerra Design Associates, Inc.



Alan A. Kretman, RLA
Director, Planning & Landscape Architecture

Copy: Doreen Frost - MN State Board of AELSLAGID
Cindy Sherman - Director of Planning, City of Brooklyn Park
Dale Dingman - Dingman Construction and Development
Jason Letourneau - Letourneau Design Associates
Greg Prasch - Lot Surveys Company
File: 08006

7200 Hudson Blvd. Suite 110 OAKDALE, MINNESOTA 55128
PHONE (651) 739-8131 FAX (651) 739-0846
www.proterradesign.com

EXHIBIT F
Pg. 2



RECEIVED

AUG - 6 2008

AUG - 6 2008



5200 85th Ave. N., Brooklyn Park, MN 55443-4301 • Phone 763-424-8000 • Fax 763-493-8391
TDD 763-493-8392

Gary E. Brown, P.E.
Director of Engineering & Building Inspections

August 4, 2008

Doreen Frost
Executive Director
Board of Architecture, Engineering, Land Surveying, Landscape Architecture,
Geoscience & Interior Design
85 E. 7th Place, Suite 160
St. Paul, MN 55101-2113

Re: Mr. Alan Kretman's Elm Creek Trail Business Park Preliminary Plans

Dear Doreen:

On June 26, 2008 I filed a formal complaint against Mr. Alan Kretman, Registered Landscape Architect # 15144, regarding his signing the plan and plat for a submittal for 3R Development. After being told that the City will not accept engineering plans submitted by Mr. Kretman, the Project Architect attempted to submit plans to be reviewed by our Building Plan Reviewers without a civil engineer and those plans were not accepted by the City. This may cause the owner significant time delays.

Mr. Alan Kretman has recently (last week), submitted Preliminary Plans (dated June 11, 2008) for the Elm Creek Trail Business Park (enclosed). He has again signed these preliminary plans that a civil engineer should have prepared, sheets C4.1 Preliminary Utility Plan, sheets C6.1, C6.2 Civil Details, as well as signing a preliminary plat sheet C5.1, that if anyone, a land surveyor should have signed.

In this particular case Mr. Kretman shows city water and sewer out in the street and there is none there. In fact, it may be several years before city water is in this street as it will require constructing under a four lane trunk highway (169). There is a 30 foot deep Metropolitan Council Interceptor sanitary sewer in place, that he shows on the plan, but this sewer can not be connected to in this location. The City of Brooklyn Park does not have any sanitary sewer or water located west of TH 169 in the entire city.

Furthermore, Mr. Kretman does not show any storm sewer on his plans, but shows a large pond which does not exist today and is less than 100 feet from what he shows on the plan as two stories of underground parking (in sandy soils). The water table in this area is approximately 15 feet below the surface.

EXHIBIT G, Pg. 1

Page 2

August 4, 2008

Letter to Doreen Frost

Executive Director

Board of Architecture, Engineering

Landscape Architecture, Geoscience

& Interior Design

This set of plans is not feasible to construct and it is extremely unfortunate that he is leading people to believe that it is feasible by signing these plans. Mr. Kretman must be brought into our Board and prohibited from continuing this unlicensed work.

Sincerely

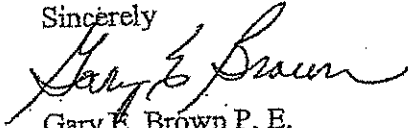

Gary E. Brown P. E.

Director of Engineering and Building Inspections

Cc: Jamie Verbrugge, City Manager
Cindy Sherman, Director of Planning
Kevin Larson, P. E. Assistant City Engineer (responsible for civil engineering plan reviews)

Attachment: Elm Creek Trail Business Park Preliminary Plans

EXHIBIT G, Pg 2

ELM CREEK TRAIL BUSINESS PARK
 BROOKLYN PARK, MINNESOTA TH169

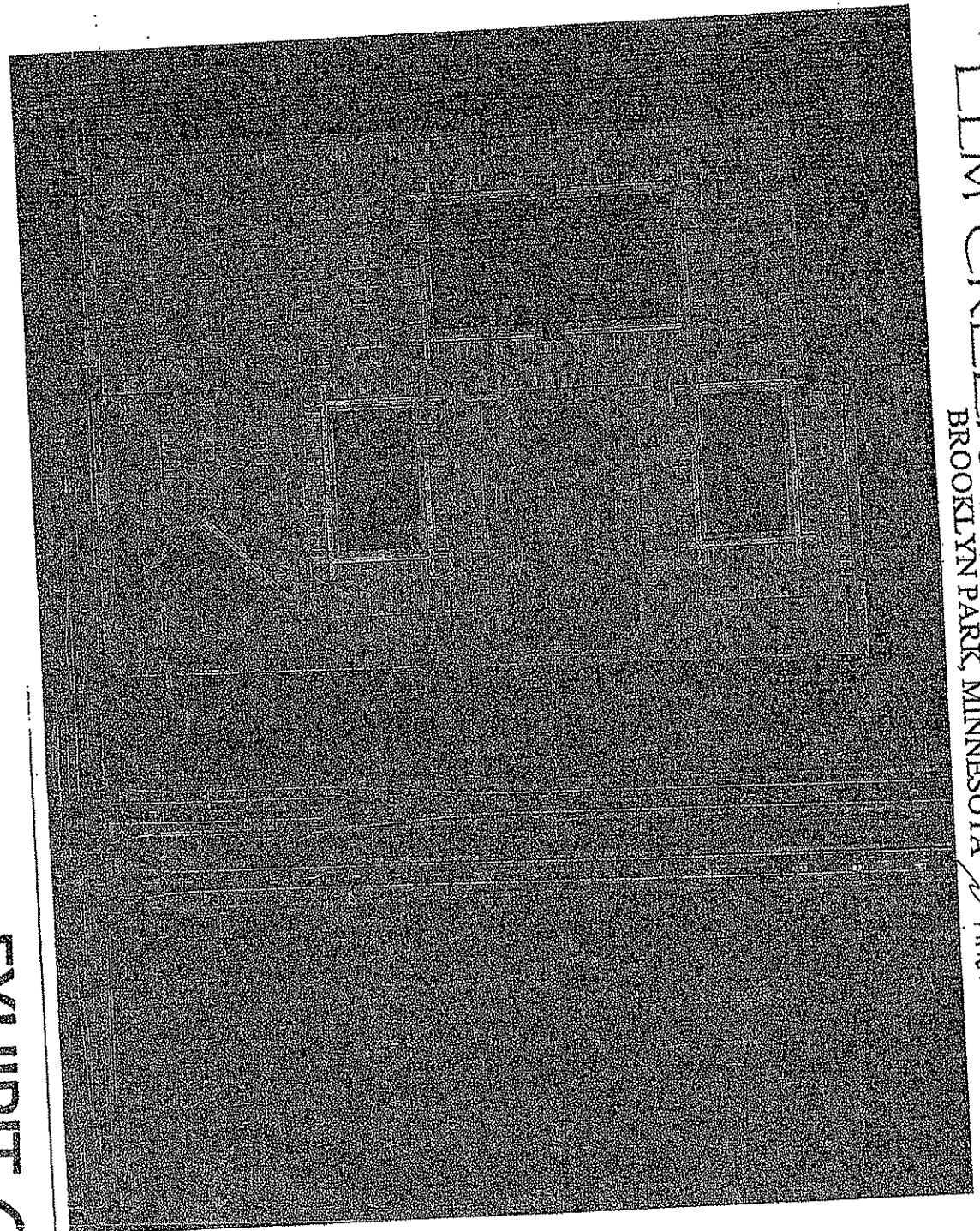
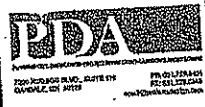

EXHIBIT G, Pg. 3

PRELIMINARY
 FOR REVIEW ONLY

M1.1
 M1.2
 M1.3
 M1.4
 M1.5
 M1.6
 M1.7
 M1.8
 M1.9
 M1.10
 M1.11
 M1.12
 M1.13
 M1.14
 M1.15
 M1.16
 M1.17
 M1.18
 M1.19
 M1.20
 M1.21
 M1.22
 M1.23
 M1.24
 M1.25
 M1.26
 M1.27
 M1.28
 M1.29
 M1.30
 M1.31
 M1.32
 M1.33
 M1.34
 M1.35
 M1.36
 M1.37
 M1.38
 M1.39
 M1.40
 M1.41
 M1.42
 M1.43
 M1.44
 M1.45
 M1.46
 M1.47
 M1.48
 M1.49
 M1.50
 M1.51
 M1.52
 M1.53
 M1.54
 M1.55
 M1.56
 M1.57
 M1.58
 M1.59
 M1.60
 M1.61
 M1.62
 M1.63
 M1.64
 M1.65
 M1.66
 M1.67
 M1.68
 M1.69
 M1.70
 M1.71
 M1.72
 M1.73
 M1.74
 M1.75
 M1.76
 M1.77
 M1.78
 M1.79
 M1.80
 M1.81
 M1.82
 M1.83
 M1.84
 M1.85
 M1.86
 M1.87
 M1.88
 M1.89
 M1.90
 M1.91
 M1.92
 M1.93
 M1.94
 M1.95
 M1.96
 M1.97
 M1.98
 M1.99
 M1.100

ELM CREEK TRAILS BUSINESS PARK
 191ST AVENUE NORTH & MN STATE HWY 169
 BROOKLYN PARK, MINNESOTA
 Parcel 169
CONCEPTUAL MASTER PLAN



Kevin Thurs
 5717 115TH AVE N
 CHAMPLIN, MN 55316
 612.308.4106

PRO-1025-01-00

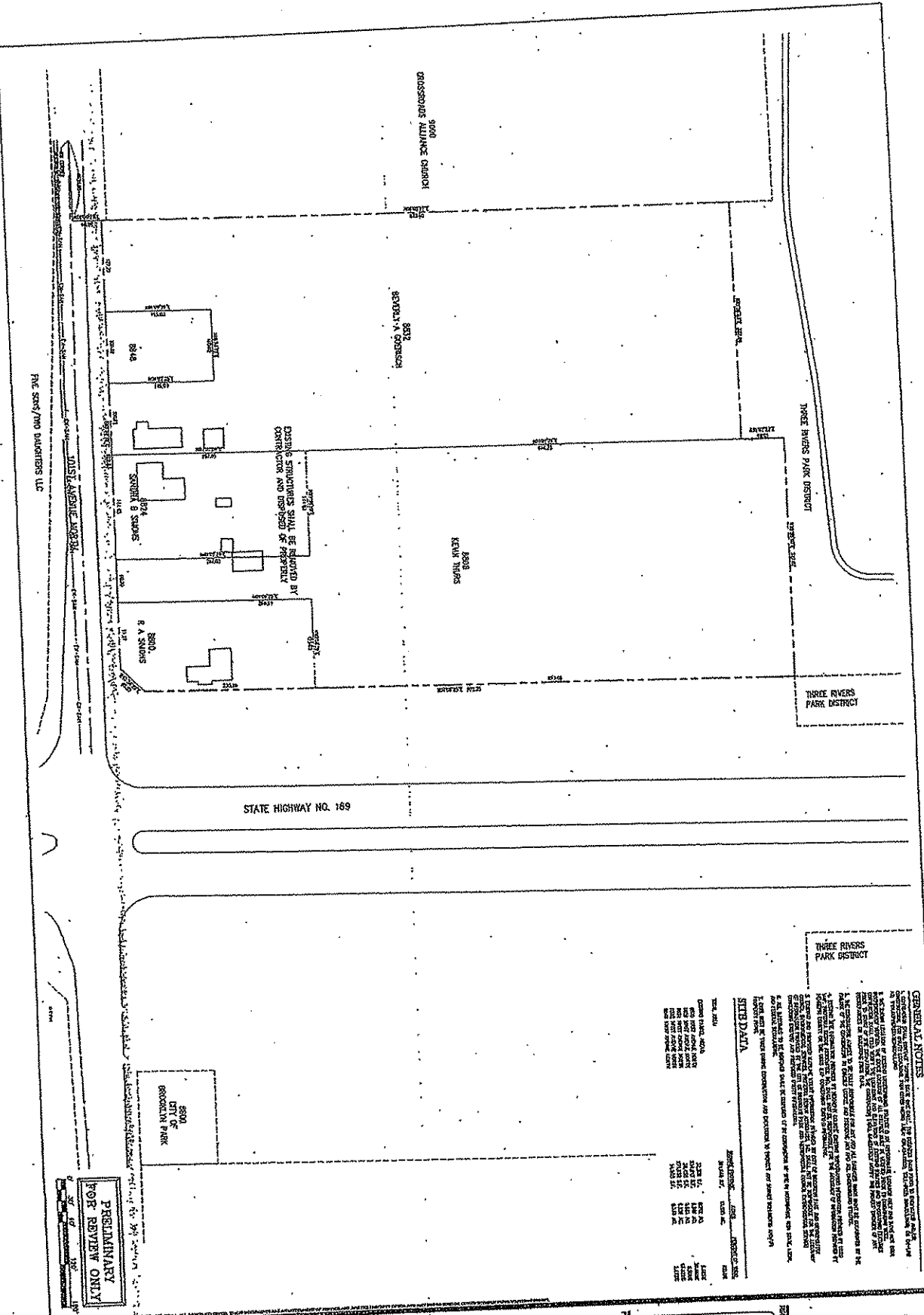

GENERAL NOTES

1. ALL DIMENSIONS ARE TO FACE UNLESS OTHERWISE NOTED.

2. ALL DIMENSIONS ARE TO FACE UNLESS OTHERWISE NOTED.

3. ALL DIMENSIONS ARE TO FACE UNLESS OTHERWISE NOTED.

4. ALL DIMENSIONS ARE TO FACE UNLESS OTHERWISE NOTED.

5. ALL DIMENSIONS ARE TO FACE UNLESS OTHERWISE NOTED.

6. ALL DIMENSIONS ARE TO FACE UNLESS OTHERWISE NOTED.

7. ALL DIMENSIONS ARE TO FACE UNLESS OTHERWISE NOTED.

8. ALL DIMENSIONS ARE TO FACE UNLESS OTHERWISE NOTED.

9. ALL DIMENSIONS ARE TO FACE UNLESS OTHERWISE NOTED.

10. ALL DIMENSIONS ARE TO FACE UNLESS OTHERWISE NOTED.

11. ALL DIMENSIONS ARE TO FACE UNLESS OTHERWISE NOTED.

12. ALL DIMENSIONS ARE TO FACE UNLESS OTHERWISE NOTED.

13. ALL DIMENSIONS ARE TO FACE UNLESS OTHERWISE NOTED.

14. ALL DIMENSIONS ARE TO FACE UNLESS OTHERWISE NOTED.

15. ALL DIMENSIONS ARE TO FACE UNLESS OTHERWISE NOTED.

16. ALL DIMENSIONS ARE TO FACE UNLESS OTHERWISE NOTED.

17. ALL DIMENSIONS ARE TO FACE UNLESS OTHERWISE NOTED.

18. ALL DIMENSIONS ARE TO FACE UNLESS OTHERWISE NOTED.

19. ALL DIMENSIONS ARE TO FACE UNLESS OTHERWISE NOTED.

20. ALL DIMENSIONS ARE TO FACE UNLESS OTHERWISE NOTED.

21. ALL DIMENSIONS ARE TO FACE UNLESS OTHERWISE NOTED.

22. ALL DIMENSIONS ARE TO FACE UNLESS OTHERWISE NOTED.

23. ALL DIMENSIONS ARE TO FACE UNLESS OTHERWISE NOTED.

24. ALL DIMENSIONS ARE TO FACE UNLESS OTHERWISE NOTED.

25. ALL DIMENSIONS ARE TO FACE UNLESS OTHERWISE NOTED.

26. ALL DIMENSIONS ARE TO FACE UNLESS OTHERWISE NOTED.

27. ALL DIMENSIONS ARE TO FACE UNLESS OTHERWISE NOTED.

28. ALL DIMENSIONS ARE TO FACE UNLESS OTHERWISE NOTED.

29. ALL DIMENSIONS ARE TO FACE UNLESS OTHERWISE NOTED.

30. ALL DIMENSIONS ARE TO FACE UNLESS OTHERWISE NOTED.

31. ALL DIMENSIONS ARE TO FACE UNLESS OTHERWISE NOTED.

32. ALL DIMENSIONS ARE TO FACE UNLESS OTHERWISE NOTED.

33. ALL DIMENSIONS ARE TO FACE UNLESS OTHERWISE NOTED.

34. ALL DIMENSIONS ARE TO FACE UNLESS OTHERWISE NOTED.

35. ALL DIMENSIONS ARE TO FACE UNLESS OTHERWISE NOTED.

36. ALL DIMENSIONS ARE TO FACE UNLESS OTHERWISE NOTED.

37. ALL DIMENSIONS ARE TO FACE UNLESS OTHERWISE NOTED.

38. ALL DIMENSIONS ARE TO FACE UNLESS OTHERWISE NOTED.

39. ALL DIMENSIONS ARE TO FACE UNLESS OTHERWISE NOTED.

40. ALL DIMENSIONS ARE TO FACE UNLESS OTHERWISE NOTED.

41. ALL DIMENSIONS ARE TO FACE UNLESS OTHERWISE NOTED.

42. ALL DIMENSIONS ARE TO FACE UNLESS OTHERWISE NOTED.

43. ALL DIMENSIONS ARE TO FACE UNLESS OTHERWISE NOTED.

44. ALL DIMENSIONS ARE TO FACE UNLESS OTHERWISE NOTED.

45. ALL DIMENSIONS ARE TO FACE UNLESS OTHERWISE NOTED.

46. ALL DIMENSIONS ARE TO FACE UNLESS OTHERWISE NOTED.

47. ALL DIMENSIONS ARE TO FACE UNLESS OTHERWISE NOTED.

48. ALL DIMENSIONS ARE TO FACE UNLESS OTHERWISE NOTED.

49. ALL DIMENSIONS ARE TO FACE UNLESS OTHERWISE NOTED.

50. ALL DIMENSIONS ARE TO FACE UNLESS OTHERWISE NOTED.

51. ALL DIMENSIONS ARE TO FACE UNLESS OTHERWISE NOTED.

52. ALL DIMENSIONS ARE TO FACE UNLESS OTHERWISE NOTED.

53. ALL DIMENSIONS ARE TO FACE UNLESS OTHERWISE NOTED.

54. ALL DIMENSIONS ARE TO FACE UNLESS OTHERWISE NOTED.

55. ALL DIMENSIONS ARE TO FACE UNLESS OTHERWISE NOTED.

56. ALL DIMENSIONS ARE TO FACE UNLESS OTHERWISE NOTED.

57. ALL DIMENSIONS ARE TO FACE UNLESS OTHERWISE NOTED.

58. ALL DIMENSIONS ARE TO FACE UNLESS OTHERWISE NOTED.

59. ALL DIMENSIONS ARE TO FACE UNLESS OTHERWISE NOTED.

60. ALL DIMENSIONS ARE TO FACE UNLESS OTHERWISE NOTED.

61. ALL DIMENSIONS ARE TO FACE UNLESS OTHERWISE NOTED.

62. ALL DIMENSIONS ARE TO FACE UNLESS OTHERWISE NOTED.

63. ALL DIMENSIONS ARE TO FACE UNLESS OTHERWISE NOTED.

64. ALL DIMENSIONS ARE TO FACE UNLESS OTHERWISE NOTED.

65. ALL DIMENSIONS ARE TO FACE UNLESS OTHERWISE NOTED.

66. ALL DIMENSIONS ARE TO FACE UNLESS OTHERWISE NOTED.

67. ALL DIMENSIONS ARE TO FACE UNLESS OTHERWISE NOTED.

68. ALL DIMENSIONS ARE TO FACE UNLESS OTHERWISE NOTED.

69. ALL DIMENSIONS ARE TO FACE UNLESS OTHERWISE NOTED.

70. ALL DIMENSIONS ARE TO FACE UNLESS OTHERWISE NOTED.

71. ALL DIMENSIONS ARE TO FACE UNLESS OTHERWISE NOTED.

72. ALL DIMENSIONS ARE TO FACE UNLESS OTHERWISE NOTED.

73. ALL DIMENSIONS ARE TO FACE UNLESS OTHERWISE NOTED.

74. ALL DIMENSIONS ARE TO FACE UNLESS OTHERWISE NOTED.

75. ALL DIMENSIONS ARE TO FACE UNLESS OTHERWISE NOTED.

76. ALL DIMENSIONS ARE TO FACE UNLESS OTHERWISE NOTED.

77. ALL DIMENSIONS ARE TO FACE UNLESS OTHERWISE NOTED.

78. ALL DIMENSIONS ARE TO FACE UNLESS OTHERWISE NOTED.

79. ALL DIMENSIONS ARE TO FACE UNLESS OTHERWISE NOTED.

80. ALL DIMENSIONS ARE TO FACE UNLESS OTHERWISE NOTED.

81. ALL DIMENSIONS ARE TO FACE UNLESS OTHERWISE NOTED.

82. ALL DIMENSIONS ARE TO FACE UNLESS OTHERWISE NOTED.

83. ALL DIMENSIONS ARE TO FACE UNLESS OTHERWISE NOTED.

84. ALL DIMENSIONS ARE TO FACE UNLESS OTHERWISE NOTED.

85. ALL DIMENSIONS ARE TO FACE UNLESS OTHERWISE NOTED.

86. ALL DIMENSIONS ARE TO FACE UNLESS OTHERWISE NOTED.

87. ALL DIMENSIONS ARE TO FACE UNLESS OTHERWISE NOTED.

88. ALL DIMENSIONS ARE TO FACE UNLESS OTHERWISE NOTED.

89. ALL DIMENSIONS ARE TO FACE UNLESS OTHERWISE NOTED.

90. ALL DIMENSIONS ARE TO FACE UNLESS OTHERWISE NOTED.

91. ALL DIMENSIONS ARE TO FACE UNLESS OTHERWISE NOTED.

92. ALL DIMENSIONS ARE TO FACE UNLESS OTHERWISE NOTED.

93. ALL DIMENSIONS ARE TO FACE UNLESS OTHERWISE NOTED.

94. ALL DIMENSIONS ARE TO FACE UNLESS OTHERWISE NOTED.

95. ALL DIMENSIONS ARE TO FACE UNLESS OTHERWISE NOTED.

96. ALL DIMENSIONS ARE TO FACE UNLESS OTHERWISE NOTED.

97. ALL DIMENSIONS ARE TO FACE UNLESS OTHERWISE NOTED.

98. ALL DIMENSIONS ARE TO FACE UNLESS OTHERWISE NOTED.

99. ALL DIMENSIONS ARE TO FACE UNLESS OTHERWISE NOTED.

100. ALL DIMENSIONS ARE TO FACE UNLESS OTHERWISE NOTED.

EXHIBIT G, P.5

HLM CREEK TRAIL BUSINESS PARK
 101ST AVENUE NORTH & MN STATE HWY 169
 BROOKLYN PARK, MINNESOTA

EXISTING CONDITIONS PLAN

PDA

Professional Design Associates

10150 Hennepin Avenue, Suite 110
 Brooklyn Park, MN 55420

TEL: 763-437-8811
 FAX: 763-437-8812
 WWW.PDADESIGN.COM

Kevin Thurs

5717 115th Avenue
 Champlin, MN 55316
 612.308.4106

KEVIN THURS
 5717 115TH AVENUE
 CHAMPLIN, MN 55316
 612.308.4106

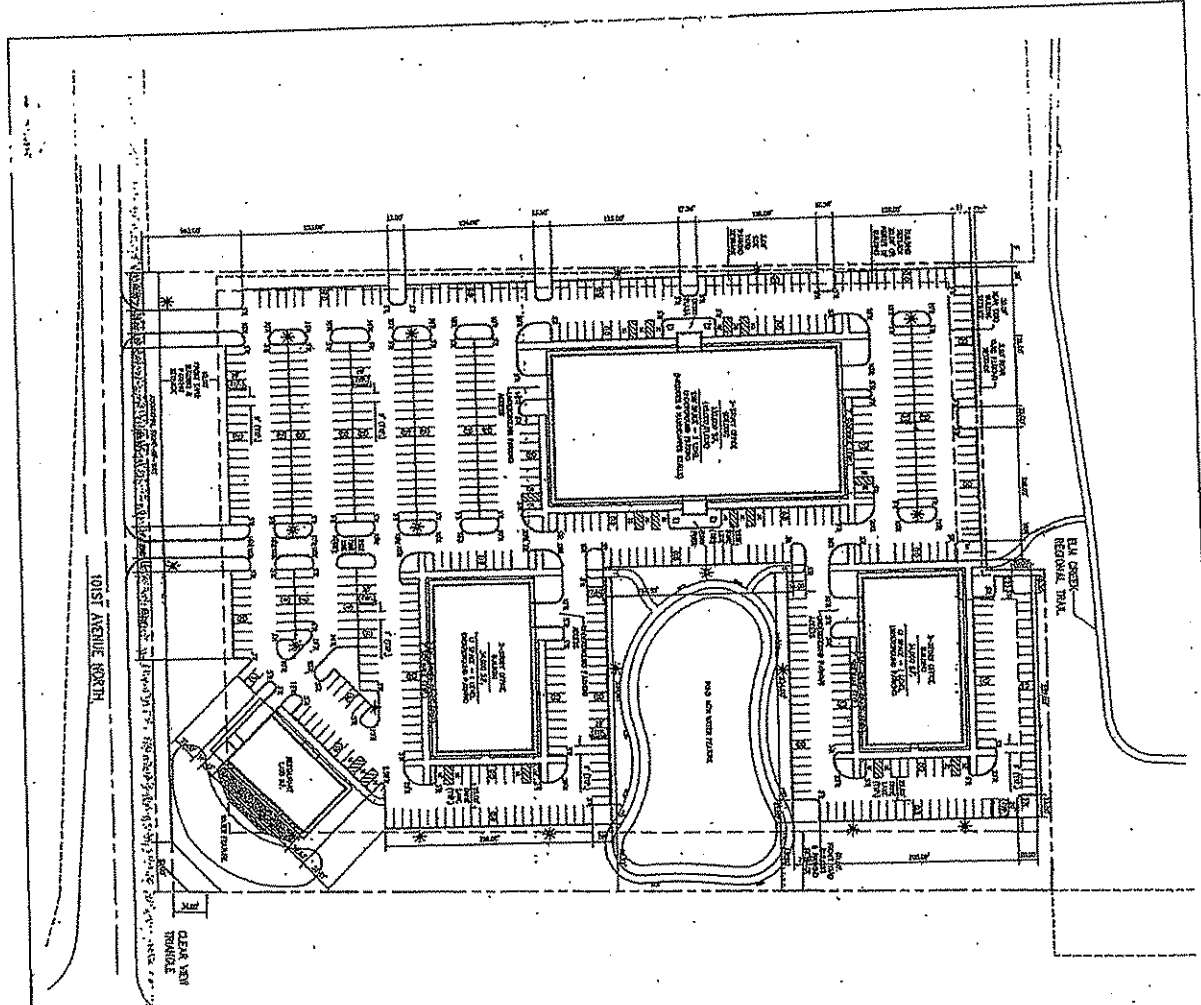

101ST AVENUE NORTH

STATE HIGHWAY NO. 169

PRELIMINARY
FOR REVIEW ONLY

OWNERS
 ELM CREEK TRAIL BUSINESS PARK
 101ST AVENUE NORTH & MN STATE HWY 169
 BROOKLYN PARK, MINNESOTA

PLANNER/LANDSCAPE ARCHITECT
 PDA
 2701 BECKMAN AVENUE, SUITE 100
 BROOKLYN PARK, MN 55430

LEGAL DESCRIPTION
 A certain parcel of land in the City of Brooklyn Park, State of Minnesota, more particularly described as follows: [Detailed description of the property boundaries and area]

NO.	DESCRIPTION	AREA (SQ. FT.)	PERCENTAGE OF TOTAL AREA
1	Building Footprint	10,000	10.0%
2	Pond	5,000	5.0%
3	Parking	85,000	85.0%
4	Other	0	0.0%
TOTAL		100,000	100.0%

GENERAL NOTES

- The site plan is based on the information provided by the owner and is not a guarantee of accuracy. The owner is responsible for providing accurate information.
- The site plan is preliminary and subject to change without notice. The owner is responsible for providing accurate information.
- The site plan is based on the information provided by the owner and is not a guarantee of accuracy. The owner is responsible for providing accurate information.
- The site plan is preliminary and subject to change without notice. The owner is responsible for providing accurate information.
- The site plan is based on the information provided by the owner and is not a guarantee of accuracy. The owner is responsible for providing accurate information.
- The site plan is preliminary and subject to change without notice. The owner is responsible for providing accurate information.

EXHIBIT G, Pg. 6

ELM CREEK TRAIL BUSINESS PARK
 101ST AVENUE NORTH & MN STATE HWY 169
 BROOKLYN PARK, MINNESOTA

PRELIMINARY SITE LAYOUT PLAN

PDA
 2701 BECKMAN AVENUE, SUITE 100
 BROOKLYN PARK, MN 55430

KEVIN THURS
 3717 145TH AVENUE
 CHAMBERLAIN, MN 55316
 612.308.4106

KEVIN THURNS
 CHAIRMAN, MAY 23, 1966
 412 308 4065

PROFESSIONAL ENGINEER
 License No. 10000
 State of Minnesota
 P. O. Box 10000
 St. Paul, Minnesota 55108

PDA
 PROFESSIONAL DESIGN ASSOCIATES, INC.
 10000 PDA DRIVE
 ST. PAUL, MINN. 55108

PROFESSIONAL ENGINEER
 License No. 10000
 State of Minnesota
 P. O. Box 10000
 St. Paul, Minnesota 55108

ELM CREEK TRAIL
BUSINESS PARK
 18151 AVENUE NORTH & HANSEN HWY 189
 BROOMFIELD PARK, MINNESOTA

70
 CC

69

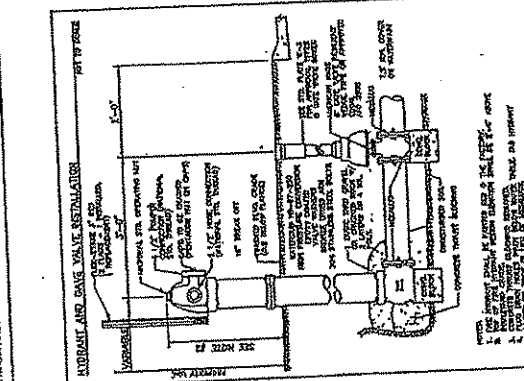
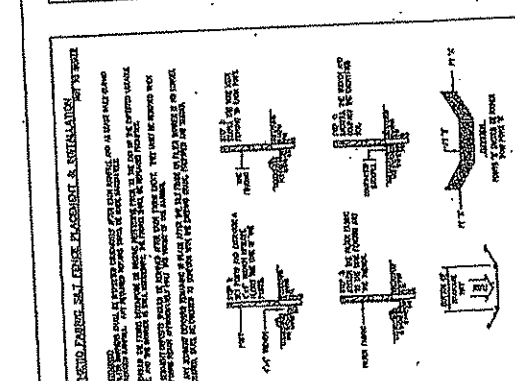
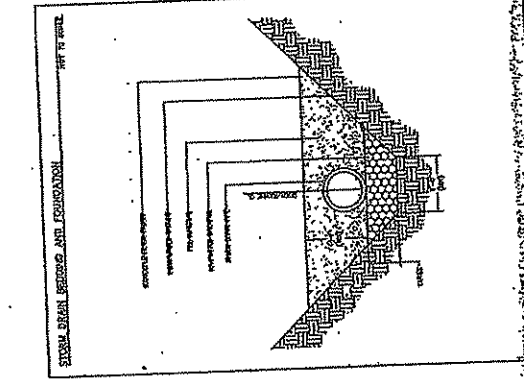
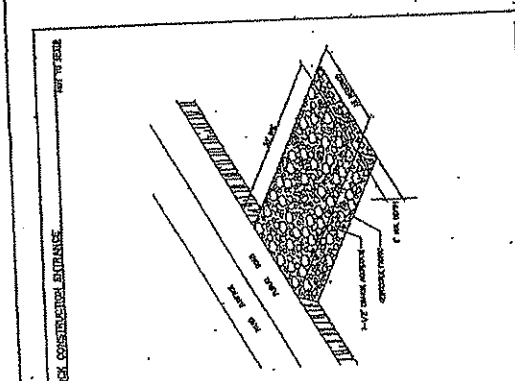
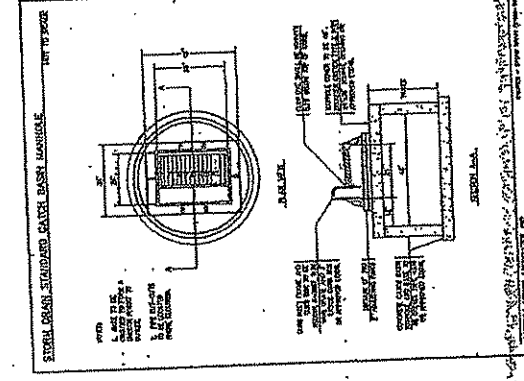
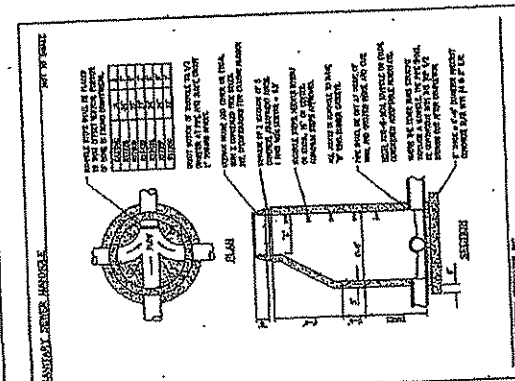
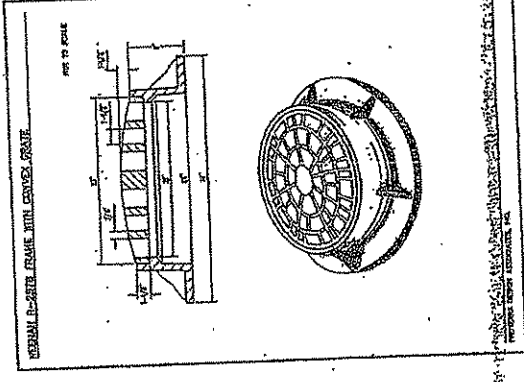
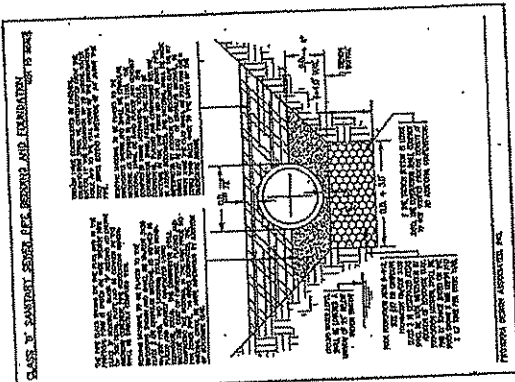

EXHIBIT G, Pg. 10

EXHIBIT G, Pg. 11

262

KEVIN THURS
CHAMPLAIN, MN 55316
612.308.4100

PERMANENT RECORD ASSOCIATES, INC.
11111 13TH AVENUE N
ROCKHURST PARK, MINNESOTA
612.308.4100

PERMANENT RECORD ASSOCIATES, INC.
11111 13TH AVENUE N
ROCKHURST PARK, MINNESOTA
612.308.4100

PERMANENT RECORD ASSOCIATES, INC.
11111 13TH AVENUE N
ROCKHURST PARK, MINNESOTA
612.308.4100

PERMANENT RECORD ASSOCIATES, INC.
11111 13TH AVENUE N
ROCKHURST PARK, MINNESOTA
612.308.4100

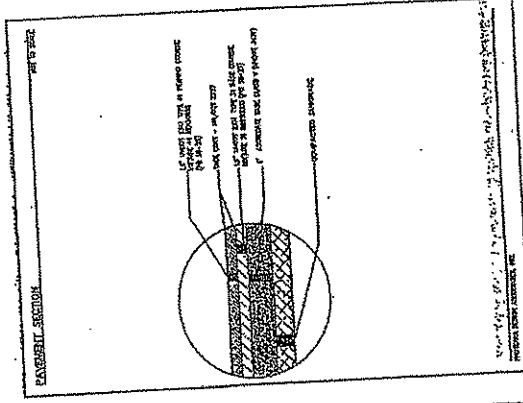
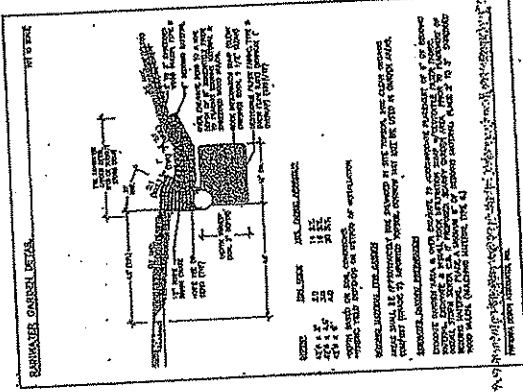
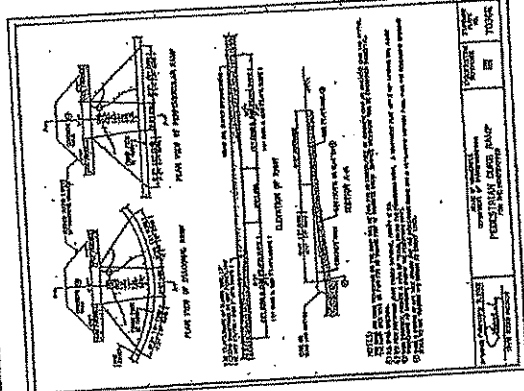
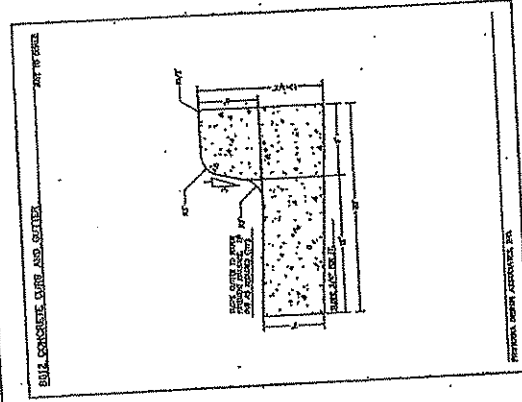
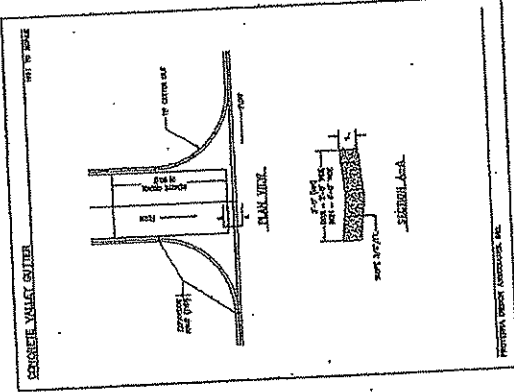
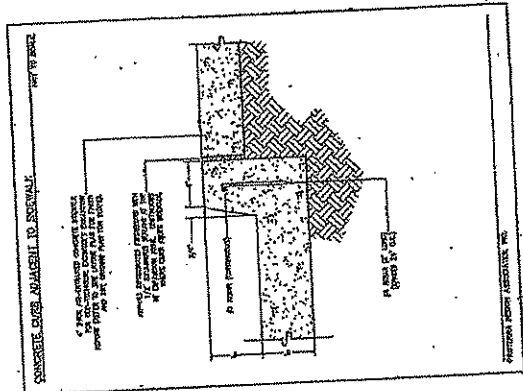

PERMANENT RECORD ASSOCIATES, INC.
11111 13TH AVENUE N
ROCKHURST PARK, MINNESOTA
612.308.4100

EXHIBIT G, 19.15

PLANTING DETAIL - DECIDUOUS TREE
 1. PLANTING DETAIL - DECIDUOUS TREE
 2. TREE STAKING DETAIL
 3. TREE WRAPPING DETAIL
 4. PLANTING DETAIL - CONIFEROUS TREE
 5. PLANTING DETAIL - SHRUB
 6. TREE PROTECTION DETAIL
 7. GENERAL PLANTING NOTES
 8. GENERAL IRRIGATION NOTES

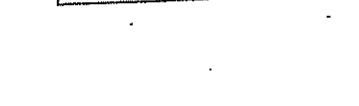
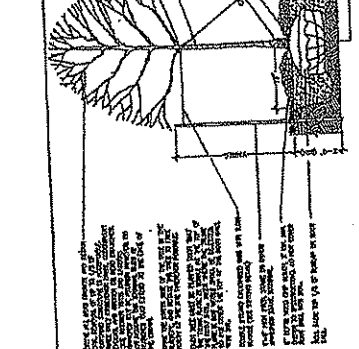
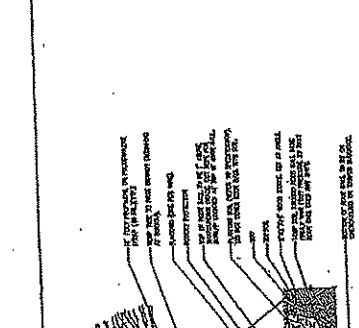
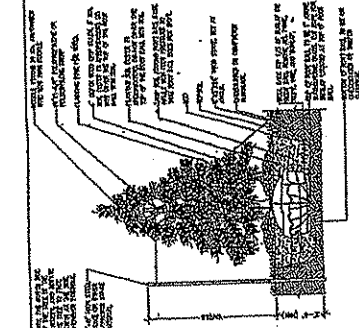
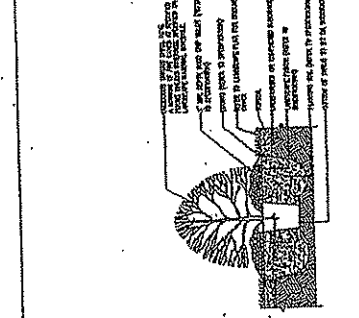
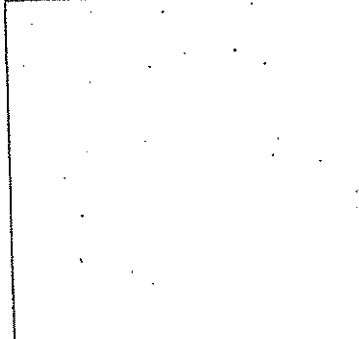

PLANTING HOLE DIMENSIONS

PLANT TYPE	PLANT SIZE	PLANTING HOLE DIMENSIONS	PLANTING HOLE DEPTH
DECIDUOUS TREE	1/2" DIA.	18" DIA.	18" DEEP
CONIFEROUS TREE	1/2" DIA.	18" DIA.	18" DEEP
SHRUB	1/2" DIA.	18" DIA.	18" DEEP
...

PLANTING HOLE DIMENSIONS

PLANT TYPE	PLANT SIZE	PLANTING HOLE DIMENSIONS	PLANTING HOLE DEPTH
DECIDUOUS TREE	1/2" DIA.	18" DIA.	18" DEEP
CONIFEROUS TREE	1/2" DIA.	18" DIA.	18" DEEP
SHRUB	1/2" DIA.	18" DIA.	18" DEEP
...

PLANTING HOLE DIMENSIONS

PLANT TYPE	PLANT SIZE	PLANTING HOLE DIMENSIONS	PLANTING HOLE DEPTH
DECIDUOUS TREE	1/2" DIA.	18" DIA.	18" DEEP
CONIFEROUS TREE	1/2" DIA.	18" DIA.	18" DEEP
SHRUB	1/2" DIA.	18" DIA.	18" DEEP
...

PLANTING HOLE DIMENSIONS

PLANT TYPE	PLANT SIZE	PLANTING HOLE DIMENSIONS	PLANTING HOLE DEPTH
DECIDUOUS TREE	1/2" DIA.	18" DIA.	18" DEEP
CONIFEROUS TREE	1/2" DIA.	18" DIA.	18" DEEP
SHRUB	1/2" DIA.	18" DIA.	18" DEEP
...

PLANTING HOLE DIMENSIONS

PLANT TYPE	PLANT SIZE	PLANTING HOLE DIMENSIONS	PLANTING HOLE DEPTH
DECIDUOUS TREE	1/2" DIA.	18" DIA.	18" DEEP
CONIFEROUS TREE	1/2" DIA.	18" DIA.	18" DEEP
SHRUB	1/2" DIA.	18" DIA.	18" DEEP
...

PLANTING HOLE DIMENSIONS

PLANT TYPE	PLANT SIZE	PLANTING HOLE DIMENSIONS	PLANTING HOLE DEPTH
DECIDUOUS TREE	1/2" DIA.	18" DIA.	18" DEEP
CONIFEROUS TREE	1/2" DIA.	18" DIA.	18" DEEP
SHRUB	1/2" DIA.	18" DIA.	18" DEEP
...

GENERAL PLANTING NOTES

1. PLANTING DETAIL - DECIDUOUS TREE
2. TREE STAKING DETAIL
3. TREE WRAPPING DETAIL
4. PLANTING DETAIL - CONIFEROUS TREE
5. PLANTING DETAIL - SHRUB
6. TREE PROTECTION DETAIL
7. GENERAL PLANTING NOTES
8. GENERAL IRRIGATION NOTES

GENERAL IRRIGATION NOTES

1. PLANTING DETAIL - DECIDUOUS TREE
2. TREE STAKING DETAIL
3. TREE WRAPPING DETAIL
4. PLANTING DETAIL - CONIFEROUS TREE
5. PLANTING DETAIL - SHRUB
6. TREE PROTECTION DETAIL
7. GENERAL PLANTING NOTES
8. GENERAL IRRIGATION NOTES

GENERAL IRRIGATION NOTES

1. PLANTING DETAIL - DECIDUOUS TREE
2. TREE STAKING DETAIL
3. TREE WRAPPING DETAIL
4. PLANTING DETAIL - CONIFEROUS TREE
5. PLANTING DETAIL - SHRUB
6. TREE PROTECTION DETAIL
7. GENERAL PLANTING NOTES
8. GENERAL IRRIGATION NOTES

GENERAL IRRIGATION NOTES

1. PLANTING DETAIL - DECIDUOUS TREE
2. TREE STAKING DETAIL
3. TREE WRAPPING DETAIL
4. PLANTING DETAIL - CONIFEROUS TREE
5. PLANTING DETAIL - SHRUB
6. TREE PROTECTION DETAIL
7. GENERAL PLANTING NOTES
8. GENERAL IRRIGATION NOTES

GENERAL IRRIGATION NOTES

1. PLANTING DETAIL - DECIDUOUS TREE
2. TREE STAKING DETAIL
3. TREE WRAPPING DETAIL
4. PLANTING DETAIL - CONIFEROUS TREE
5. PLANTING DETAIL - SHRUB
6. TREE PROTECTION DETAIL
7. GENERAL PLANTING NOTES
8. GENERAL IRRIGATION NOTES

GENERAL IRRIGATION NOTES

1. PLANTING DETAIL - DECIDUOUS TREE
2. TREE STAKING DETAIL
3. TREE WRAPPING DETAIL
4. PLANTING DETAIL - CONIFEROUS TREE
5. PLANTING DETAIL - SHRUB
6. TREE PROTECTION DETAIL
7. GENERAL PLANTING NOTES
8. GENERAL IRRIGATION NOTES

H.M. CREEK TRAIL
 BUSINESS PARK
 1000 NORTH & 10TH AVENUE
 HOOGMOED PARK, MINNESOTA

PDV
 PLANTING DETAIL - DECIDUOUS TREE
 PLANTING DETAIL - CONIFEROUS TREE
 PLANTING DETAIL - SHRUB
 TREE STAKING DETAIL
 TREE WRAPPING DETAIL
 TREE PROTECTION DETAIL

KEVIN THURS
 5747 KEVIN AVENUE
 CHAMBERLAIN, MN 55916
 612.288.4166

PLANTING DETAIL - DECIDUOUS TREE
 PLANTING DETAIL - CONIFEROUS TREE
 PLANTING DETAIL - SHRUB
 TREE STAKING DETAIL
 TREE WRAPPING DETAIL
 TREE PROTECTION DETAIL

PLANTING DETAIL - DECIDUOUS TREE
 PLANTING DETAIL - CONIFEROUS TREE
 PLANTING DETAIL - SHRUB
 TREE STAKING DETAIL
 TREE WRAPPING DETAIL
 TREE PROTECTION DETAIL

PLANTING DETAIL - DECIDUOUS TREE
 PLANTING DETAIL - CONIFEROUS TREE
 PLANTING DETAIL - SHRUB
 TREE STAKING DETAIL
 TREE WRAPPING DETAIL
 TREE PROTECTION DETAIL

PLANTING DETAIL - DECIDUOUS TREE
 PLANTING DETAIL - CONIFEROUS TREE
 PLANTING DETAIL - SHRUB
 TREE STAKING DETAIL
 TREE WRAPPING DETAIL
 TREE PROTECTION DETAIL



JAN - 9 2009  brooklyn park
engineering

5200 85th Ave. N., Brooklyn Park, MN 55443-4301 • Phone 763-424-8000 • Fax 763-493-8391
TDD 763-493-8392

Gary E. Brown, P.E.
Director of Engineering & Building Inspections

JAN 09 2009 *ll*

January 8, 2009

Lynette DuFresne, Investigator
Minnesota Board of Architecture, Engineering, Land Surveying,
Landscape Architecture, Geoscience & Interior Design
85 East 7th Place, Suite 160
St. Paul, MN. 55101

Subject: Alan Kretman, Landscape Architect, #15144, File Number 2009-0002

Dear Ms. DuFresne:

This letter is in response to your letter of December 22, 2008, asking for additional information regarding the above mentioned complaint. On June 23rd, I submitted a complaint regarding Mr. Kretman in his submittal of 3R's Child Development Center located on 85th Avenue just east of City Hall. The 3R's application was for a CUP to allow construction of a 15,000 sq. ft. Day Care and all site improvements. Those plans were submitted for Planning approval and Mr. Kretman was advised that the building permit would not be issued until and unless a civil engineer submitted the plans with an approved signature and registration. That particular project is now under construction and a civil engineer did sign the set of plans that were approved.

On August 4, 2008, I submitted additional information regarding a second submittal that Mr. Kretman made to the City of Brooklyn Park regarding the Elm Creek Trail Business Park. In the case of the Elm Creek Trail Business Park preliminary plans, they were submitted for conceptual plan approval only. Those plans were recommended for approval by the City's Planning Commission even though they were inconsistent with the City's staging plan. On November 24, 2008, the City Council voted to deny the Elm Creek Trail Business Park concept plan. I have attached the City's agenda item as well as approved minutes referencing that action. As you can see by the City Council agenda item, the Elm Creek Trail Business Park was a concept plan. Typically, in a concept plan we would like to see some sort of an idea of the location of water and sanitary sewer connections and how the developer is proposing to handle their storm water, especially since in this case, a pond with a water feature was being proposed immediately adjacent to the two level underground parking facility. Also, how is the developer planning on handling the infiltration/seepage that will likely occur from an adjacent pond getting into two floors of underground parking constructed in sandy soils. In addition, two 34,000 square foot buildings were being proposed and underground parking is also proposed for both of these sites. 101st Avenue is the roadway that this proposed development is located on and it is an unimproved road with recycled asphalt being used as a surface. It is important to note that the City was very concerned as to

whether or not this project was economically feasible at this time, since the owners of the property definitely wanted to develop their property in the most cost effective manner possible.

I have also enclosed a recent complaint that the owners have filed against the City for denying the approval of the project. As you can see in the complaint on page 5, paragraph 14, indicates that the City refused to accept the submittal by Mr. Kretman because the information was incomplete. The owners and Mr. Kretman insisted on having the Planning Commission review their concept plan despite the lack of information referenced above, needed to make a recommendation. Specifically on items such as where the water and sanitary sewer and storm sewer utilities were going to come from. Please note that the enclosed colored aerial shows the nearest City water 1 mile to the east, City storm sewer over 3,000 feet to the west. The City can construct a line to connect to the Met Council Interceptor sewer, but there is not an existing City sewer within 1 mile of the property. In paragraph 22, of the complaint, the City Council voted to deny the concept plan #08-123 for the following reasons:

1. The application is premature for the following reasons:
 - A. Roadway improvements are not in place or planned to serve the type of development proposed.
 - B. Brooklyn Park public utilities are not readily available to serve the site.
 - C. There are currently approximately 400 acres of vacant land with City services available for office development.
 - D. The current market does not warrant deviating from the staging plan without specific user identified.
 - E. The Comprehensive Plan does not call for utilities to be staged into this area at this time.
 - F. The zoning of the property does not allow for the development as proposed.
 - G. The civil plans have not been designed by an engineer licensed in the State of Minnesota.

Mr. Kretman has provided advice to the property owners that has given them a false sense of the ability to develop their property. Again, it is my belief that the development would not have progressed had a licensed Professional Engineer been consulted.

I have enclosed overall utility plans (on aerials) showing the proposed development and the available water and sanitary sewer to the site.

No other City approvals have been given.

The applicant did not, nor did his consulting firm, present any documentation that other professionals had worked on the plans.

At this point in time, plans have not been amended to include requested changes.

Lynette DuFresne, Investigator
January 8, 2009
Page 3

The only disclaimer on the plans is that they are stamped "preliminary for review only." There is no disclaimer "not for construction." Assistant City Engineer, Kevin Larson, reviewed the plans. Kevin is also a Professional Engineer in the State of Minnesota. His direct dial number is (763) 493-8114, and his address is the same as our City Hall address. It should be noted that Mr. Kretman asked to see the sanitary sewer plans for the Met Council's Interceptor sewer even though he was told by Kevin that a direct connection is not permitted for services. Cindy Sherman, the Planning Director, also reviewed the plans. Her direct dial number is (763) 493-8051.

Sincerely,



Gary E. Brown, P.E.
Director of Engineering and Building Inspections

GEB/md

Enclosures:

City Council Agenda Item 6.3, Elm Creek Business Park, November 24, 2008
Minutes of City Council Meeting, November 24, 2008
Summons by Mr. Kretman's Clients
2 Aerial Maps Showing City Utilities

cc: Cindy Sherman, Planning Director
Kevin Larson, Assistant City Engineer
Jamie Verbrugge, City Manager

EXHIBIT H - Pg 3

City of Brooklyn Park Planning Staff Report

Agenda Item No:	6.3	Meeting Date:	November 24, 2008
Agenda Section:	Land Use Action	Originating Department:	Planning Division
Resolution:	N/A	Prepared By:	Cindy Sherman
Ordinance:	N/A		
No. of Attachments:	5	Presented By:	Cindy Sherman
Item:	Elm Creek Business Park Concept Plan		

City Managers Recommendation: MOTION _____ SECOND _____ TO WAIVE THE READING AND ADOPT RESOLUTION 2008-_____ TO (APPROVE OR DENY) THE ELM CREEK TRAIL BUSINESS PARK CONCEPT PLAN, SUBJECT TO CONDITIONS IN THE RESOLUTION.

Planning Commission Recommendation: The Planning Commission voted 5-2 to recommend approval of the concept plan subject to the conditions outlined in the attached resolution.

Overview:

The property owners located at the Northwest corner of 101st Ave. N and Highway 169 have submitted a concept plan for their property. The plan as submitted includes three office buildings and a restaurant site.

The property is currently zoned R-1, Urban Reserve. The ordinance states:

(A) *Purpose.* The "R-1" Urban Reserve District is intended to provide the following:

(1) A district which allows for the orderly phasing and development of land until city services, including sanitary sewer, storm sewer, and water, are extended into the area in compliance with the Comprehensive Plan.

(2) A district for uses that typically require significant amounts of open land area such as athletic and cultural facilities, country clubs, government buildings, educational uses, and land reclamation.

(3) A district which allows for short-term agriculture uses and very low density residential uses and those accessory uses customarily incidental to them.

The current comprehensive plan that governs the property is the *2004 Update to the Northern Brooklyn Park Master Plan*. This plan includes a staging plan for extension of utilities. This property is located in Stage 5 which is planned to be the last area of the city to receive public utility service.

Since 1963 the City has had a growth management policy to moderate the pace of growth and allow roads, utilities, and other services to be in place ahead of development. Growth is planned in accordance with the land use plan, the staging plan and the capital improvements plan. The comprehensive plan allows for flexibility in

EXHIBIT A - Pg. 4

the staged growth plan by requiring a comprehensive plan amendment when a development proposal meets the City's intention.

Concept Plan:

The applicants have submitted a concept plan to receive comments on the proposal and to begin discussions regarding the rezoning and comprehensive plan amendment that are necessary for development to occur.

Staff received plans on July 30 and provided the applicants with a list of issues/concerns. We met with the applicants to review the comments and proposed revisions. The engineer was to submit the revisions on October 27. We did not receive the revised plans on that date so we have based our review on the original submittal and offer the following comments.

1. The concept plan does not include how utilities will be extended, constructed, and financed to serve the site. Water is currently located at the intersection of Oak Grove Parkway and West Broadway. The sanitary sewer located under 101st Avenue is the Elm Creek Interceptor which is up to 30' deep and can not provide direct service. The plan does not address the lateral system needed to serve the site.
2. Parking on the site needs to be provided for the intended uses shown and are based on gross square footage. The plan shows parking for storerooms/warehousing but the buildings are identified as office. Additionally, the numbers do not add up or calculate correctly.
3. Soil borings will be necessary to determine if underground parking is feasible based on the anticipated water table.
4. Based on new policies in effect regarding ground water protection, the city is not supportive of large open water features.
5. Information regarding the preliminary designs of the buildings is required.
6. Projects of this size require a traffic study and one will be required for the project to move beyond a concept. A traffic study will examine the necessary improvements to the existing roadway system in order to accommodate the proposed uses.
7. From air photos, it appears that there may be a wetland at the northern portion of the site. A wetland delineation report is required and should be completed early on to determine the impact on the site.
8. The site is located adjacent to the North Hennepin Regional Trail Corridor (sometimes referred to as the Elm Creek or Rush Creek Trails). Three Rivers Park District has indicated that spurs to the trail must be public and spaced far apart. The access shown appears to be private. Any access will have to be approved by the Park District.
9. The site is subject to park dedication at the time of development. In this case land dedication will be required. The business land dedication rate is 5 percent of the site. The required dedication will be a strip of land adjacent to the existing corridor equal to 5 percent of the land area, excluding wetlands.

10. The site is currently zoned R-1, Urban Reserve District. This zoning allows for the orderly phasing and development of land until city services are extended into the area in compliance with the Comprehensive Plan. The land would need to be rezoned to allow development to occur.
11. This proposal is not consistent with the staging plan within the Comprehensive Plan. In order to deviate from the phasing plan a comprehensive plan amendment will be necessary.

Staff is aware that many of the comments have been addressed by the applicant's engineer although not submitted. As with other concept plans we provide general comments as to the uses and site layout. The bigger discussion items related to this concept plan are whether or not the land is ready for rezoning and if a comprehensive plan amendment is appropriate.

Attachments:

- 6.3 LOCATION MAP
- 6.3 RESOLUTIONS (2)
- 6.3 PLANS
- 6.3 UNAPPROVED PLANNING COMMISSION MINUTES

**Concept Plan #08-123 Elm Creek Business Park
NW corner of TH 169 & 101st Ave. N.**

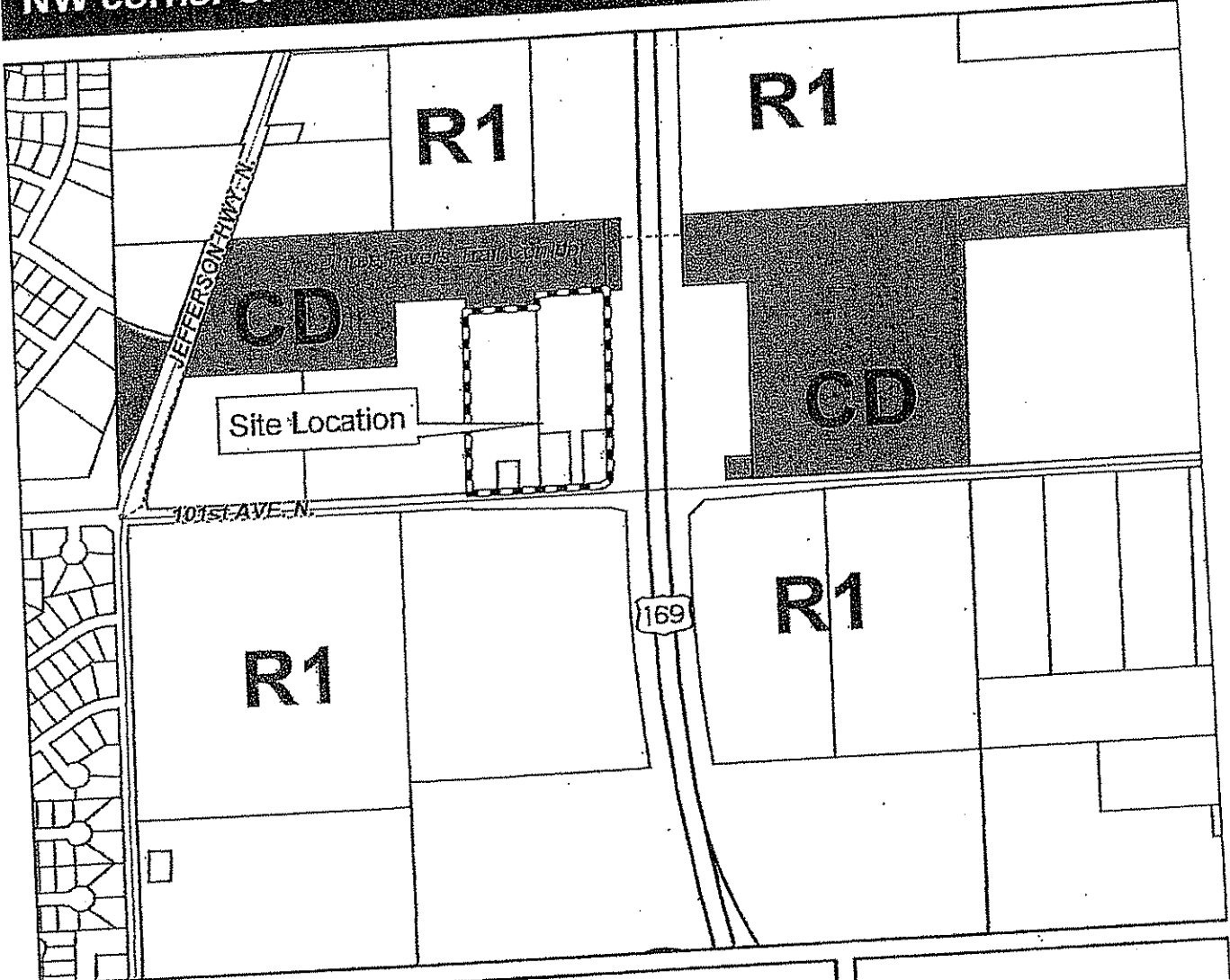

Residential Districts	Business Districts
R1 - Urban Reserve	B1 - Office Park
R2 - Single Family Estate	B2 - Neighborhood Retail
R2B - Single Family (85')	B3 - General Business
R3 - Single Family (80')	B4 - Vehicle Sales & Showroom
R3A - Single Family (75')	BP - Business Park
R4 - Single and Two Family	I - General Industrial
R4A - Townhouse	Special Districts
R4B - Detached Townhouse	PCDD - Planned Community Development District
R5 - Multiple Family	PUD - Planned Unit Development
R6 - Multiple Family	TC - Town Center
R7 - Multiple Family	CD - Conservancy District
Overlay Districts	PI - Public Institution
HO - Highway Overlay	VR - Village Redevelopment

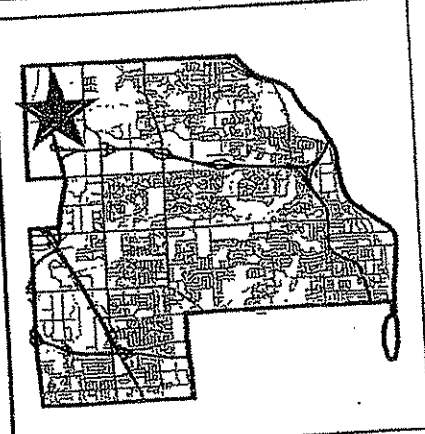

This is an area identification map showing the property proposed for development and area zoning classifications. Map Date November 16, 2008.

RESOLUTION #2008-___

RESOLUTION TO APPROVE CONCEPT PLAN #08-123
ELM CREEK TRAILS BUSINESS PARK
LOCATED AT THE NORTHWEST CORNER OF 101ST AVE. NORTH AND HIGHWAY 169

PLANNING COMMISSION FILE #08-123

WHEREAS, an application was submitted for a Concept Plan in the R-1, Urban Reserve District as described in Section 152.031 of City Code on property legally described as:

INSERT LEGAL

WHEREAS, the property owners have submitted an application for concept review; and

WHEREAS, the property is zoned R-1, Urban Reserve district; and

WHEREAS, the property is not scheduled for public utilities in at least the next 5 years; and

WHEREAS, the applicants have indicated their desire to develop outside of the city's staging plan; and

WHEREAS, City may consider modifying the staging of utilities if there is a compelling reason to do so; and

WHEREAS, the concept plan outlines a general site layout with a mix of office buildings and a restaurant site which are desirable uses.

NOW, THEREFORE, BE IT RESOLVED BY THE CITY COUNCIL OF THE CITY OF BROOKLYN PARK that the concept plan for Elm Creek Trails Business Park be APPROVED subject to the following conditions:

1. A plan for how utilities will be extended, constructed, and financed to serve the site shall be submitted.
2. Parking on the site needs to meet the ordinance for the intended uses.

EXHIBIT A- Pg. 8

3. Soil borings will be necessary to determine if underground parking is feasible based on the anticipated water table. The amount of development will be impacted if underground parking is not feasible.
4. Storm water management must meet city/watershed regulation.
5. Information regarding the preliminary designs of the buildings is required.
6. A traffic study will be required for the project to move beyond a concept. A traffic study will examine the necessary improvements to the existing roadway system in order to accommodate the proposed uses.
7. A wetland delineation report is required and shall be completed prior to the next stage of development.
8. Any trail access will have to be approved by the Three Rivers Park District.
9. Park dedication is subject to the approval of the Parks Advisory Commission and staff will recommend a 5% land dedication, excluding wetlands adjacent to the trail corridor.
10. Future applications will include a rezoning of the property.
11. A comprehensive plan amendment must be approved to deviate from the city staging plan.
12. The City shall require a signed letter of intent with a specific user in order for the concept plan to move forward to development plan.

RESOLUTION #2008-____

RESOLUTION TO DENY CONCEPT PLAN #08-123
ELM CREEK TRAILS BUSINESS PARK
LOCATED AT THE NORTHWEST CORNER OF 101ST AVE. NORTH AND HIGHWAY 169
PLANNING COMMISSION FILE #08-123

WHEREAS, an application was submitted for a Concept Plan in the R-1, Urban Reserve District as described in Section 152.031 of City Code on property legally described as:

INSERT LEGAL

WHEREAS, the property owners have submitted an application for concept review; and

WHEREAS, the property is zoned R-1, Urban Reserve district; and

WHEREAS, the property is not scheduled for public utilities in at least the next 5 years; and

WHEREAS, the applicants have indicated their desire to develop outside of the city's staging plan; and

WHEREAS, City may consider modifying the staging of utilities if there is a compelling reason to do so.

NOW, THEREFORE, BE IT RESOLVED BY THE CITY COUNCIL OF THE CITY OF BROOKLYN PARK that the concept plan for Elm Creek Trails Business Park be DENIED based on the following findings:

1. The application is premature for the following reasons:
 - a. Roadway improvements are not in place or planned to serve the type of development proposed.
 - b. Public Utilities are not readily available to serve the site.
 - c. There are currently approximately 400 acres of vacant land with city services available for office development.
 - d. The current market does not warrant deviating from the staging plan without a specific user identified.

ELM CREEK TRAILS BUSINESS PARK

BROOKLYN PARK, MINNESOTA

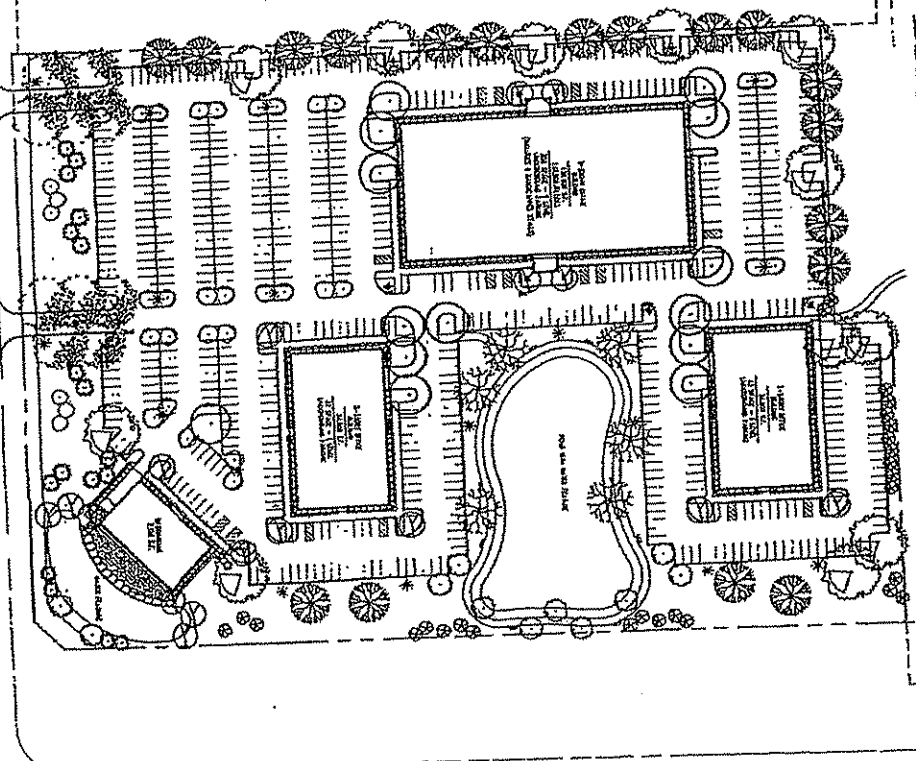

STATE HIGHWAY NO. 169

WEST AVENUE NORTH

EXHIBIT H.
Pg. 11

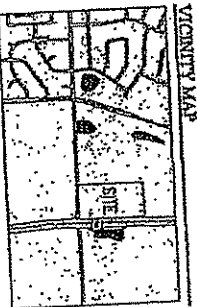

- LEGEND**
- | EXISTING | PROPOSED |
|------------------------------------------------------------------------------------------------------------------------------------------------------------------------------------------------------------------------------------------------------------------------------------------------------------|------------------------------------------------------------------------------------------------------------------------------------------------------------------------------------------------------------------------------------------------------------------------------------------------------------|
| <ul style="list-style-type: none"> 1. Existing Building Footprint 2. Existing Parking 3. Existing Driveway 4. Existing Utility Lines 5. Existing Easements 6. Existing Right-of-Way 7. Existing Topography 8. Existing Trees | <ul style="list-style-type: none"> 1. Proposed Building Footprint 2. Proposed Parking 3. Proposed Driveway 4. Proposed Utility Lines 5. Proposed Easements 6. Proposed Right-of-Way 7. Proposed Topography 8. Proposed Trees |

DRAWING INDEX

001	GENERAL NOTES
002	CONCEPTUAL LAYOUT PLAN
003	PROPOSED DEVELOPMENT PLAN
004	PROPOSED SITE PLAN
005	PROPOSED PAVING PLAN
006	PROPOSED UTILITY PLAN
007	PROPOSED LANDSCAPE PLAN
008	PROPOSED LIGHTING PLAN
009	PROPOSED SIGNAGE PLAN
010	PROPOSED FENCE PLAN
011	PROPOSED EROSION CONTROL PLAN
012	PROPOSED TRAFFIC CALMING PLAN
013	PROPOSED SECURITY PLAN
014	PROPOSED ACCESSIBILITY PLAN
015	PROPOSED BIODIVERSITY PLAN
016	PROPOSED HISTORIC PRESERVATION PLAN
017	PROPOSED CULTURAL RESOURCE PLAN
018	PROPOSED ARCHITECTURAL PLAN
019	PROPOSED INTERIOR PLAN
020	PROPOSED MECHANICAL PLAN
021	PROPOSED ELECTRICAL PLAN
022	PROPOSED PLUMBING PLAN
023	PROPOSED HEATING PLAN
024	PROPOSED COOLING PLAN
025	PROPOSED FIRE PLAN
026	PROPOSED SAFETY PLAN
027	PROPOSED SECURITY PLAN
028	PROPOSED ACCESSIBILITY PLAN
029	PROPOSED BIODIVERSITY PLAN
030	PROPOSED HISTORIC PRESERVATION PLAN
031	PROPOSED CULTURAL RESOURCE PLAN
032	PROPOSED ARCHITECTURAL PLAN
033	PROPOSED INTERIOR PLAN
034	PROPOSED MECHANICAL PLAN
035	PROPOSED ELECTRICAL PLAN
036	PROPOSED PLUMBING PLAN
037	PROPOSED HEATING PLAN
038	PROPOSED COOLING PLAN
039	PROPOSED FIRE PLAN
040	PROPOSED SAFETY PLAN
041	PROPOSED SECURITY PLAN
042	PROPOSED ACCESSIBILITY PLAN
043	PROPOSED BIODIVERSITY PLAN
044	PROPOSED HISTORIC PRESERVATION PLAN
045	PROPOSED CULTURAL RESOURCE PLAN
046	PROPOSED ARCHITECTURAL PLAN
047	PROPOSED INTERIOR PLAN
048	PROPOSED MECHANICAL PLAN
049	PROPOSED ELECTRICAL PLAN
050	PROPOSED PLUMBING PLAN
051	PROPOSED HEATING PLAN
052	PROPOSED COOLING PLAN
053	PROPOSED FIRE PLAN
054	PROPOSED SAFETY PLAN
055	PROPOSED SECURITY PLAN
056	PROPOSED ACCESSIBILITY PLAN
057	PROPOSED BIODIVERSITY PLAN
058	PROPOSED HISTORIC PRESERVATION PLAN
059	PROPOSED CULTURAL RESOURCE PLAN
060	PROPOSED ARCHITECTURAL PLAN
061	PROPOSED INTERIOR PLAN
062	PROPOSED MECHANICAL PLAN
063	PROPOSED ELECTRICAL PLAN
064	PROPOSED PLUMBING PLAN
065	PROPOSED HEATING PLAN
066	PROPOSED COOLING PLAN
067	PROPOSED FIRE PLAN
068	PROPOSED SAFETY PLAN
069	PROPOSED SECURITY PLAN
070	PROPOSED ACCESSIBILITY PLAN
071	PROPOSED BIODIVERSITY PLAN
072	PROPOSED HISTORIC PRESERVATION PLAN
073	PROPOSED CULTURAL RESOURCE PLAN
074	PROPOSED ARCHITECTURAL PLAN
075	PROPOSED INTERIOR PLAN
076	PROPOSED MECHANICAL PLAN
077	PROPOSED ELECTRICAL PLAN
078	PROPOSED PLUMBING PLAN
079	PROPOSED HEATING PLAN
080	PROPOSED COOLING PLAN
081	PROPOSED FIRE PLAN
082	PROPOSED SAFETY PLAN
083	PROPOSED SECURITY PLAN
084	PROPOSED ACCESSIBILITY PLAN
085	PROPOSED BIODIVERSITY PLAN
086	PROPOSED HISTORIC PRESERVATION PLAN
087	PROPOSED CULTURAL RESOURCE PLAN
088	PROPOSED ARCHITECTURAL PLAN
089	PROPOSED INTERIOR PLAN
090	PROPOSED MECHANICAL PLAN
091	PROPOSED ELECTRICAL PLAN
092	PROPOSED PLUMBING PLAN
093	PROPOSED HEATING PLAN
094	PROPOSED COOLING PLAN
095	PROPOSED FIRE PLAN
096	PROPOSED SAFETY PLAN
097	PROPOSED SECURITY PLAN
098	PROPOSED ACCESSIBILITY PLAN
099	PROPOSED BIODIVERSITY PLAN
100	PROPOSED HISTORIC PRESERVATION PLAN

LEGAL DESCRIPTION

THESE PLANS ARE SUBMITTED FOR THE RECORD OF THE CITY OF BROOKLYN PARK, MINNESOTA, FOR THE ELIMINATION OF THE EXISTING EASEMENTS AND THE ESTABLISHMENT OF THE PROPOSED EASEMENTS AND INTERESTS IN THE LANDS DESCRIBED IN THE LEGAL DESCRIPTION HEREIN.

THESE PLANS ARE SUBMITTED FOR THE RECORD OF THE CITY OF BROOKLYN PARK, MINNESOTA, FOR THE ELIMINATION OF THE EXISTING EASEMENTS AND THE ESTABLISHMENT OF THE PROPOSED EASEMENTS AND INTERESTS IN THE LANDS DESCRIBED IN THE LEGAL DESCRIPTION HEREIN.

PLANNER/LANDSCAPE ARCHITECT

PLANNING & LANDSCAPE ARCHITECTURE, INC.

11111 UNIVERSITY AVENUE, SUITE 1115

MINNETONKA, MN 55369

PHONE: 952.891.1115

FAX: 952.891.1116

WWW: WWW.PLA.COM

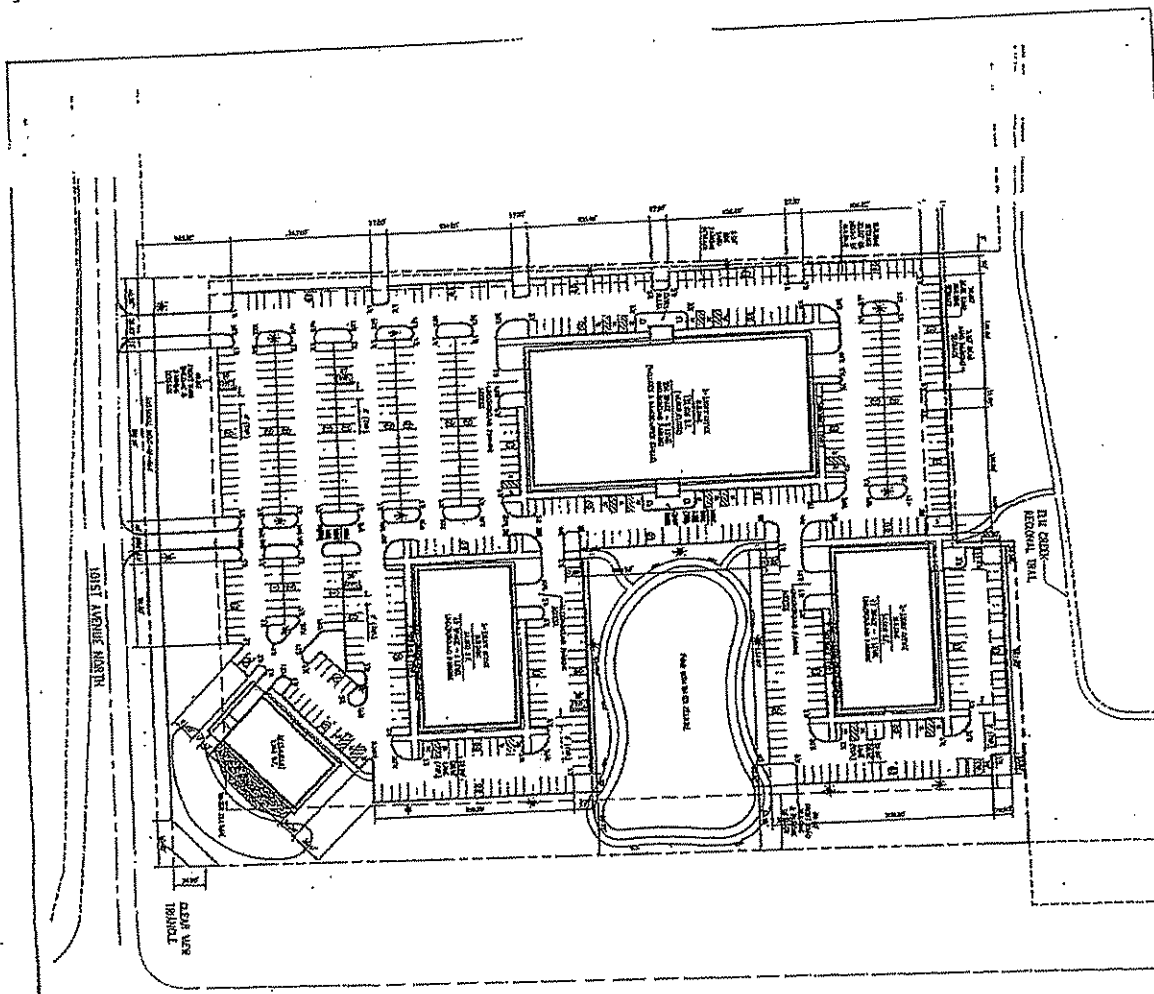

STATE HIGHWAY NO. 169

EXHIBIT H - Pg. 13

GENERAL NOTES:
 1. ALL DIMENSIONS ARE TO FACE UNLESS OTHERWISE NOTED.
 2. ALL CONSTRUCTION SHALL BE IN ACCORDANCE WITH THE LATEST EDITIONS OF THE MINNESOTA BUILDING CODE AND THE MINNESOTA ELECTRICAL CODE.
 3. ALL UTILITIES SHALL BE DEPTH MARKED PRIOR TO CONSTRUCTION.
 4. THE OWNER SHALL BE RESPONSIBLE FOR OBTAINING ALL NECESSARY PERMITS AND APPROVALS FROM THE APPROPRIATE AGENCIES.
 5. THE CONTRACTOR SHALL BE RESPONSIBLE FOR OBTAINING ALL NECESSARY PERMITS AND APPROVALS FROM THE APPROPRIATE AGENCIES.
 6. ALL MATERIALS AND WORKMANSHIP SHALL BE SUBJECT TO INSPECTION AND APPROVAL BY THE CITY ENGINEER.
 7. THE CONTRACTOR SHALL MAINTAIN ACCESS TO ALL ADJACENT PROPERTIES AT ALL TIMES.
 8. ALL UTILITIES SHALL BE DEPTH MARKED PRIOR TO CONSTRUCTION.
 9. THE CONTRACTOR SHALL BE RESPONSIBLE FOR OBTAINING ALL NECESSARY PERMITS AND APPROVALS FROM THE APPROPRIATE AGENCIES.
 10. ALL MATERIALS AND WORKMANSHIP SHALL BE SUBJECT TO INSPECTION AND APPROVAL BY THE CITY ENGINEER.

OWNERS:
 ELM CREEK TRAIL BUSINESS PARK
 101ST AVENUE NORTH
 BROOKLYN PARK, MN 55420

PLANNING AND SCAPE ARCHITECT:
 PDA
 5717 115TH AVENUE
 CHAMPLAIN, MN 55916
 612.306.4106

DESIGNER:
 PDA
 5717 115TH AVENUE
 CHAMPLAIN, MN 55916
 612.306.4106

DATE: 10/15/08

SCALE: AS SHOWN

PROJECT: ELM CREEK TRAIL BUSINESS PARK

LOCATION: 101ST AVENUE NORTH & MN STATE HWY 169, BROOKLYN PARK, MINNESOTA

PRELIMINARY FOR REVIEW ONLY

ELM CREEK TRAIL BUSINESS PARK
 101ST AVENUE NORTH & MN STATE HWY 169
 BROOKLYN PARK, MINNESOTA

PDA
 5717 115TH AVENUE
 CHAMPLAIN, MN 55916
 612.306.4106

KEVIN THURS
 5717 115TH AVENUE
 CHAMPLAIN, MN 55916
 612.306.4106

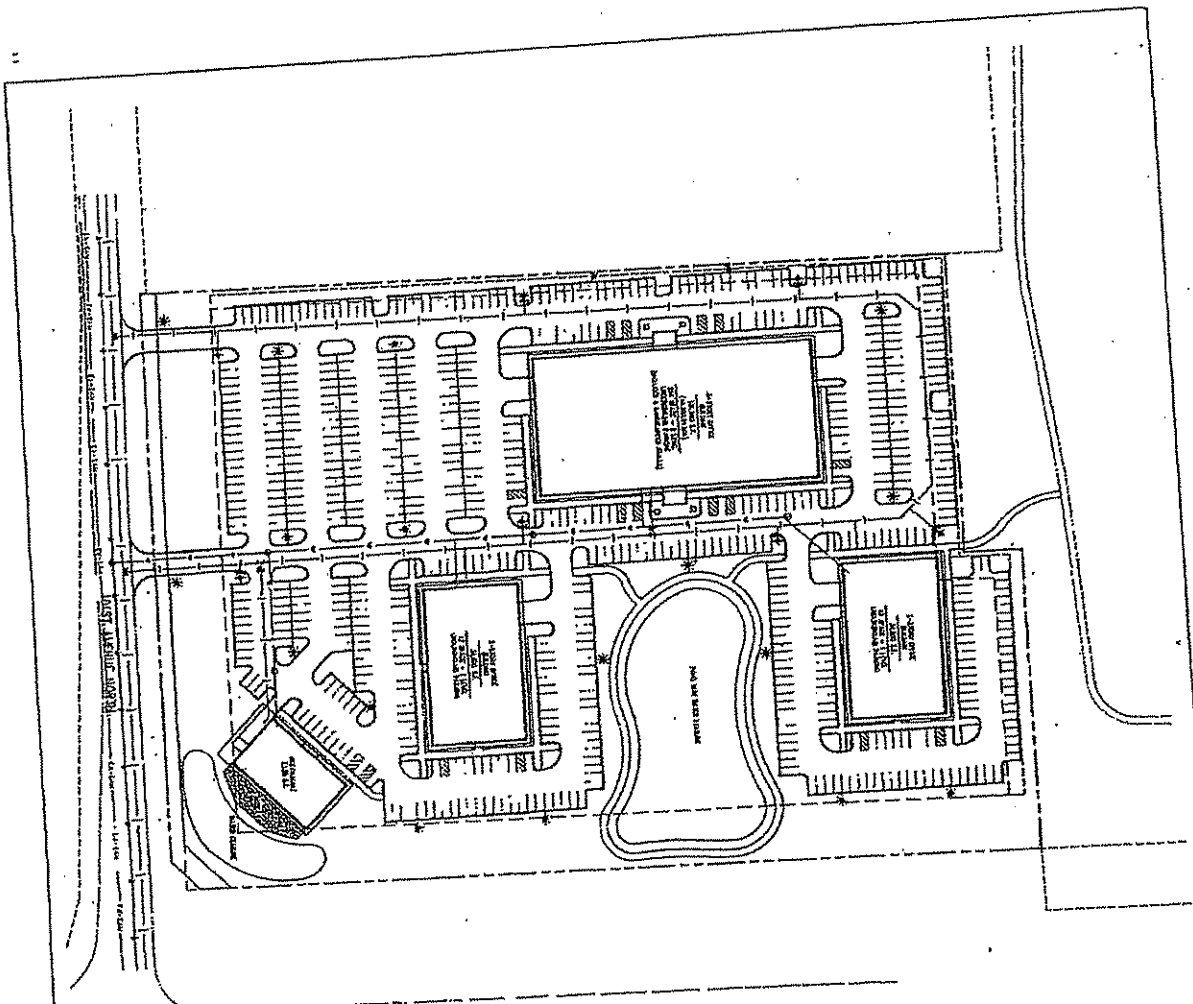

STATE HIGHWAY NO. 169

EXHIBIT H - Pg. 14

<p>1. All utility lines shown on this plan are assumed to be in place and correct. The engineer is not responsible for the accuracy of the utility lines shown on this plan.</p>
<p>2. The engineer is not responsible for the accuracy of the utility lines shown on this plan.</p>
<p>3. The engineer is not responsible for the accuracy of the utility lines shown on this plan.</p>
<p>4. The engineer is not responsible for the accuracy of the utility lines shown on this plan.</p>

GENERAL NOTES

1. All utility lines shown on this plan are assumed to be in place and correct. The engineer is not responsible for the accuracy of the utility lines shown on this plan.

2. The engineer is not responsible for the accuracy of the utility lines shown on this plan.

3. The engineer is not responsible for the accuracy of the utility lines shown on this plan.

4. The engineer is not responsible for the accuracy of the utility lines shown on this plan.

UTILITY NOTES

1. All utility lines shown on this plan are assumed to be in place and correct. The engineer is not responsible for the accuracy of the utility lines shown on this plan.

2. The engineer is not responsible for the accuracy of the utility lines shown on this plan.

3. The engineer is not responsible for the accuracy of the utility lines shown on this plan.

4. The engineer is not responsible for the accuracy of the utility lines shown on this plan.

CONSTRUCTION SEQUENCE

1. Excavate and install utility lines.
2. Construct foundation and walls.
3. Construct roof and interior walls.
4. Construct exterior walls and finish.
5. Construct parking lots and drive.
6. Construct site improvements.

LEGEND

EXISTING	PROPOSED
<ul style="list-style-type: none"> 1. Existing building 2. Existing parking lot 3. Existing drive 4. Existing utility lines 5. Existing site improvements 	<ul style="list-style-type: none"> 1. Proposed building 2. Proposed parking lot 3. Proposed drive 4. Proposed utility lines 5. Proposed site improvements

PRELIMINARY FOR REVIEW ONLY

ELM CREEK TRAIL BUSINESS PARK
101ST AVENUE NORTH & MN STATE HWY 169
BROOKLYN PARK, MINNESOTA

BY: **PRELIMINARY UTILITY PLAN**



KEVIN THURS
570 11TH AVENUE
CHAMPLAIN, MN 55316
612.308.4106

PROFESSIONAL ENGINEER
No. 10111
State of Minnesota

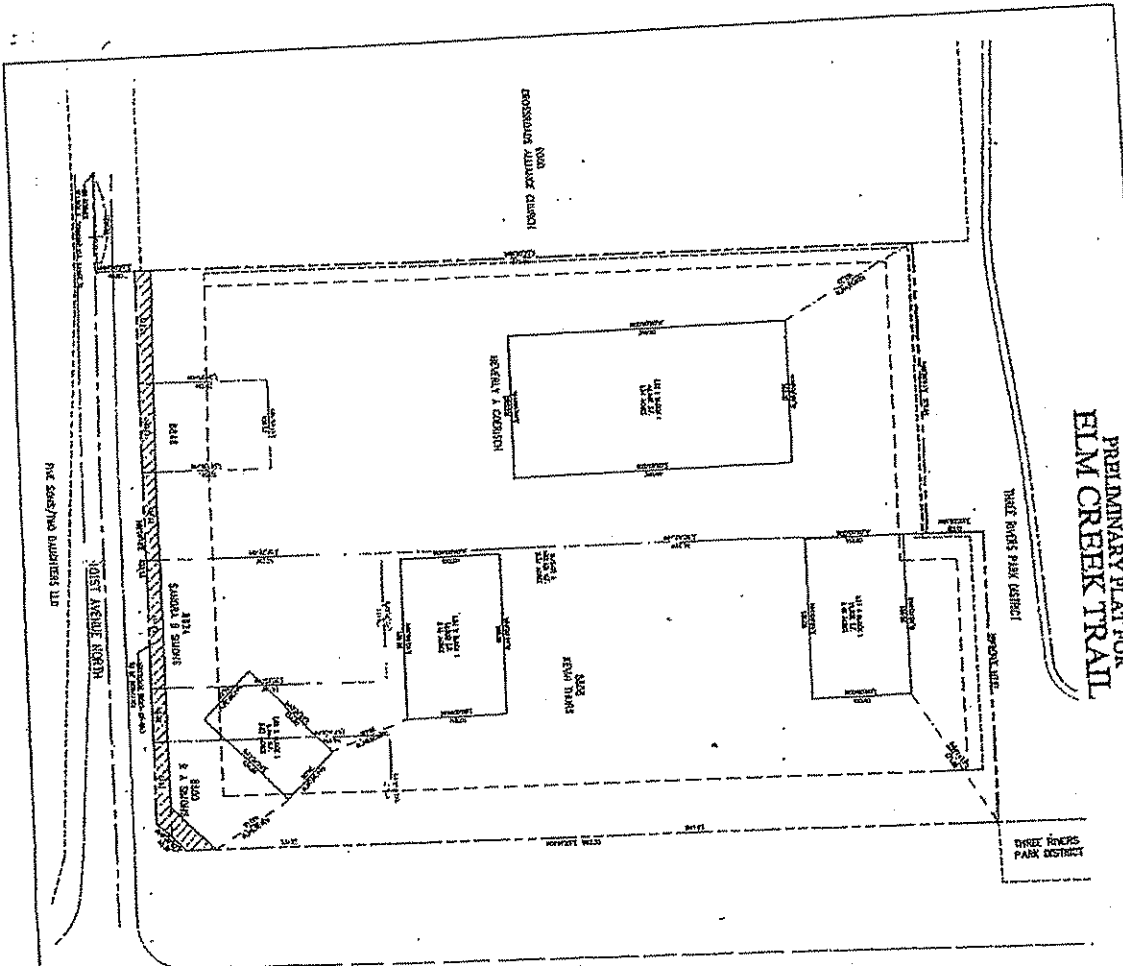

**PRELIMINARY PLAT FOR
ELM CREEK TRAIL
BUSINESS PARK**

EXHIBIT H - 9.15

GENERAL NOTES

1. THE PLAT IS SUBJECT TO ALL APPLICABLE ORDINANCES, REGULATIONS AND ORDERS OF THE CITY OF CHANDLER, ARIZONA.
2. THE PLAT IS SUBJECT TO ALL APPLICABLE ORDINANCES, REGULATIONS AND ORDERS OF THE COUNTY OF MARICOPA, ARIZONA.
3. THE PLAT IS SUBJECT TO ALL APPLICABLE ORDINANCES, REGULATIONS AND ORDERS OF THE STATE OF ARIZONA.
4. THE PLAT IS SUBJECT TO ALL APPLICABLE ORDINANCES, REGULATIONS AND ORDERS OF THE FEDERAL GOVERNMENT.
5. THE PLAT IS SUBJECT TO ALL APPLICABLE ORDINANCES, REGULATIONS AND ORDERS OF ANY OTHER APPLICABLE AGENCY.
6. THE PLAT IS SUBJECT TO ALL APPLICABLE ORDINANCES, REGULATIONS AND ORDERS OF ANY OTHER APPLICABLE AGENCY.
7. THE PLAT IS SUBJECT TO ALL APPLICABLE ORDINANCES, REGULATIONS AND ORDERS OF ANY OTHER APPLICABLE AGENCY.
8. THE PLAT IS SUBJECT TO ALL APPLICABLE ORDINANCES, REGULATIONS AND ORDERS OF ANY OTHER APPLICABLE AGENCY.
9. THE PLAT IS SUBJECT TO ALL APPLICABLE ORDINANCES, REGULATIONS AND ORDERS OF ANY OTHER APPLICABLE AGENCY.
10. THE PLAT IS SUBJECT TO ALL APPLICABLE ORDINANCES, REGULATIONS AND ORDERS OF ANY OTHER APPLICABLE AGENCY.

OWNER'S

PLANNING AND DESIGN ARCHITECT

LEGAL DESCRIPTION

STATE DATA

DATE

SCALE

PRELIMINARY FOR REVIEW ONLY

**PRELIMINARY
FOR REVIEW ONLY**

**ELM CREEK TRAIL
BUSINESS PARK**
WEST AVENUE NORTH & MN STATE HWY 169
BROOKLYN PARK, MINNESOTA
PRELIMINARY PLAT



KEVIN THURS
5717 118TH AVENUE
CHANDLER, AZ 85226
612.508.4106

PLANNING AND DESIGN ARCHITECT

STATE DATA

REGULAR BROOKLYN PARK CITY COUNCIL MEETING

Monday, November 24, 2008
7:00 p.m.

Brooklyn Park Council Chambers
5200 85th Avenue North

CALL TO ORDER - Mayor Lampi

PRESENT: Mayor Steve Lampi; Council Members Rich Gates, Terry Gearin, Jeff Lunde, Mark Mata, Jeanette Meyer, and Mike Trepanier; City Manager Jamie Verbrugge; City Attorney Jim Thomson; Community Development Director Robert Schreier; Finance Director Cory Kampf, City Engineer Gary Brown and City Clerk Devin Montero.

ABSENT: None.

Mayor Lampi opened the meeting with the Pledge of Allegiance.

Open Forum:

- 1) Billy Bishop-Comparisons of other cities with crime statistics and the need for more police officers
- 2) Jim Dietel-Concerns with safety and taxes.

3A. MOTION GEARIN, SECOND MEYER TO APPROVE THE AGENDA AS SUBMITTED BY THE CITY CLERK WITH ITEMS 4.4 AND 4.7 PULLED FROM THE CONSENT AGENDA FOR SEPARATE CONSIDERATION. MOTION PASSED UNANIMOUSLY.

4.0 MOTION MEYER, SECOND GATES TO APPROVE THE FOLLOWING ADMINISTRATIVE CONSENT ITEM: (Items #4.4 and 4.7 were removed for separate consideration.

4.1 TO RELEASE THE ENGINEERING ESCROW (\$364.48) FOR SATISFACTORY COMPLETION OF THE "NOBLE PARKWAY MOBIL" CONDITIONAL USE PERMIT PROJECT #08-102 LOCATED AT 9500 NOBLE PARKWAY N FOR NOBLE PARKWAY MOBIL.

4.1 TO RELEASE THE CASH BOND (\$4,300) AND RELEASE THE ENGINEERING ESCROW (\$4,000) FOR SATISFACTORY COMPLETION OF THE "CLEAN AIR PRODUCTS" PROJECT #08-002 LOCATED AT 8605 WYOMING AVENUE N FOR SHAW CONSTRUCTION.

4.1 TO RELEASE THE CASH BOND (\$5,000) AND RELEASE THE ENGINEERING ESCROW (\$2,000) FOR SATISFACTORY COMPLETION OF THE "TOPLINE FEDERAL CREDIT UNION" PROJECT #06-132 LOCATED AT 9790 SCHREIBER TERRACE N FOR GREINER CONSTRUCTION.

4.1 TO RELEASE THE ON-SITE SUBDIVISION PERFORMANCE BOND #105020647 BY TRAVELERS CASUALTY & SURETY COMPANY OF AMERICA

EXHIBIT H - Pg. 16

(\$227,800) AND REDUCE CASH BOND FROM \$11,900 TO \$5,000 AND REDUCE THE ENGINEERING ESCROW FROM \$15,839.03 TO \$1,000 FOR SATISFACTORY PROGRESS OF THE "TCF NATIONAL BANK" PROJECT #06-146, LOCATED AT 8057 BROOKLYN BLVD. FOR TCF NATIONAL BANK.

4.2 TO WAIVE THE READING AND ADOPT RESOLUTION #2008-209 APPROVING FINAL PLAT OF "NORTHWIND PLAZA" AT THE NORTHEAST CORNER OF BROOKLYN BOULEVARD AND WEST BROADWAY.

4.3 TO APPROVE A VEHICLE LEASING LICENSE FOR PUBLIC STORAGE AT 7800 73RD AVENUE NORTH.

4.5 TO WAIVE THE READING AND ADOPT RESOLUTION #2008-210 APPROVING A TIME EXTENSION FOR CONDITIONAL USE PERMIT #07-118 FOR A 91,000-SQUARE-FOOT MULTI-TENANT RETAIL BUILDING AT THE NORTHWEST CORNER OF HIGHWAY 610 AND ZANE AVENUE NORTH.

4.6 TO EXTEND TINA CARSTEN'S APPOINTMENT OF COMMISSIONER TO THE SHINGLE CREEK AND WEST MISSISSIPPI WATERSHED COMMISSIONS TO JANUARY 31, 2009.

4.8 TO SET A PUBLIC HEARING ON DECEMBER 15, 2008 TO CONSIDER THE ISSUANCE OF AN ON-SALE INTOXICATING LIQUOR LICENSE FOR KALILA II, INC., DBA VICTORY GRILL AT 9690 COLORADO LANE NORTH.

MOTION PASSED UNANIMOUSLY.

4.4 Council Member Mata stated that the parking lot reconstruction was unwarranted should not be paved and would not support the motion.

4.4 MOTION MEYER, SECOND GEARIN TO WAIVE THE READING AND ADOPT RESOLUTION #2008-211 TO APPROVE CHANGE ORDER NO. 1 FOR GREENHAVEN PARK PARKING LOT RECONSTRUCTION FOR MN ROADWAYS CO. MOTION PASSED. (6 TO 1) MATA VOTED NO.

4.7 Council Member Trepanier stated that he would abstain from voting on the motion because he was an association member.

4.7 MOTION GEARIN, SECOND GATES TO WAIVE THE READING AND ADOPT RESOLUTION #2008-212 TO ACCEPT THE FOUNDERS PARK TRAIL EASEMENT FROM THE WOODLAND VILLAS ASSOCIATION. MOTION PASSED. TREPANIER ABSTAINED.

5.1 Betty Peterson, Licensing, briefed Council on the renewal of the currency exchange license for Minnesota Currency Exchange Corporation at 7646 Brooklyn Boulevard North.

EXHIBIT H- Pg. 17

BROOKLYN PARK COUNCIL MEETING; NOVEMBER 24, 2008...Page 3

5.1 Mayor Lampi opened the public hearing to consider the renewal of the currency exchange license for Minnesota Currency Exchange Corporation at 7646 Brooklyn Boulevard North. No one addressed the Council.

5.1 Mayor Lampi closed the public hearing and return the item to the table for consideration.

5.1 MOTION MEYER, SECOND TREPANIER TO RECOMMEND THE RENEWAL OF THE CURRENCY EXCHANGE LICENSE FOR MINNESOTA CURRENCY EXCHANGE CORPORATION AT 7646 BROOKLYN BOULEVARD NORTH TO THE COMMISSIONER OF COMMERCE. MOTION PASSED UNANIMOUSLY.

5.2 Betty Peterson, Licensing, briefed Council on the renewal of the currency exchange license for New Unbank Company LLP at 6319 Zane Avenue North.

5.2 Mayor Lampi opened the public hearing to consider the renewal of the currency exchange license for New Unbank Company LLP at 6319 Zane Avenue North.

5.2 Mayor Lampi closed the public hearing and return the item to the table for consideration.

5.2 MOTION MEYER, SECOND GATES TO RECOMMEND THE RENEWAL OF THE CURRENCY EXCHANGE LICENSE FOR NEW UNBANK COMPANY LLP AT 6319 ZANE AVENUE NORTH TO THE COMMISSIONER OF COMMERCE. MOTION PASSED UNANIMOUSLY.

6.1 Cindy Sherman, Planning Director, briefed Council on the Exclusive Event Center conditional use permit to allow an event center of approximately 1,100 sq. ft in the Brookdale Crossing mall at 2857 Brookdale Drive.

6.1 MOTION MEYER, SECOND GEARIN TO WAIVE THE READING AND ADOPT RESOLUTION #2008-213 FOR CONDITIONAL USE PERMIT (#08-121) FOR AN EVENT CENTER AT 2857 BROOKDALE DRIVE WITH THE ADDITON OF GENERAL CONDITION 1.07 THAT THE OCCUPANCY MAXIMUM IS SET BY CITY FIRE CHIEF. MOTION PASSED UNANIMOUSLY.

6.2 Cindy Sherman, Planning Director, briefed Council on the Gateway Addition preliminary and final plat to subdivide approximately 91.32 acres into two outlots southeast of Jefferson Highway and future TH 610.

6.2 MOTION TREPANIER, SECOND GATES TO WAIVE THE READING AND ADOPT RESOLUTION #2008-214 APPROVING PRELIMINARY AND FINAL PLAT #07-130 OF "GATEWAY ADDITION" SUBDIVIDING 91.32 ACRES INTO TWO OUTLOTS SOUTHEAST OF JEFFERSON HIGHWAY AND FUTURE TRUNK HIGHWAY 610. MOTION PASSED UNANIMOUSLY.

EXHIBIT H - Pg. 18

6.3 Cindy Sherman, Planning Director, briefed Council on the Elm Creek Business Park Concept Plan.

Discussions were held on: Plan conflicting with the Comprehensive Plan; getting sewer and water to the site; obtaining water from Maple Grove; city philosophy when phasing plan was instituted; issues with developing outside city's staging; development along Highway 169 important; type of buildings being recommended; without concept plan the developers can't advertise it; church property developed into senior housing and not taxable; and concerns with churches taking away private development.

City Attorney Thomson stated that the taxability of the development could only be determined when it came forward. He stated that the action before council was just creating two lots and the tax consequences was not a legitimate reason for making a decision.

Other discussions: Approving concept plan and excluding the preliminary plan; standards in the concept plan and development being different; having a back up if the Target development doesn't happen; opportunities missed on other developments due to waiting for the Target developments; T.H. 610 completion needed; greater expectations for that staging area; church property; units per acre proposed; changing the density to medium; and a reason for having a staging plan.

City Attorney Thomson stated Council could change the density any time in the future with direction but the action before council was to approve a lot split and not an appropriate time to change the density and was for a future council decision.

He stated the property was zone R1 and would not be rezoned to MX until public services were extended that site; council still had time to change the density if the council wanted to do that in the future for the land. He stated that because the property was zoned R1 a religious institution was a permitted use in the R1 zoning district and was possible after the lot was created and conveyed to the church they might want to use it as a church use until the time it developed and would be an allowable use.

6.3 MOTION TREPANIER, SECOND GATES TO WAIVE THE READING AND ADOPT RESOLUTION #2008-215 TO DENY THE ELM CREEK TRAIL BUSINESS PARK CONCEPT PLAN, SUBJECT TO CONDITIONS IN THE RESOLUTION. MOTION PASSED ON A ROLL CALL VOTE: YES: LUNDE, LAMPL, MEYER, GATES, TREPANIER; NO: GEARIN, MATA.

8.1 Jamie Verbrugge, City Manager, briefed Council on the 2009 budget with more options related to the requested increases, existing operations and possible reduction on the overall levy impact.

At 9:08 p.m. City Attorney Thomson departed.

EXHIBIT H - Pg. 19

BROOKLYN PARK COUNCIL MEETING; NOVEMBER 24, 2008...Page 5

Discussions were held on: Properties increasing and decreasing in value; how many properties used in data were foreclosures; how park and recreation programs would be analyzed for program success; goal should be zero increase; and 2% impact on taxes.

Council Member Meyer stated the D.A.R.E. program should be in the budget reduction and was not an effective program. She stated it was unfair to ask tax payers to pay for it.

8.1 MOTION TREPANIER, SECOND LAMPI THAT STAFF IMPLEMENT THE CITY MANAGERS RECOMMENDED BUDGET ADJUSTMENTS FOR INCLUSION IN THE 2009 BUDGET AND THAT STAFF BE DIRECTED TO PREPARE FOR THE TRUTH IN TAXATION HEARIN ON DECEMBER 1, 2008 WITH THESE FIGURES.MOTION PASSED. (5 TO 2) LUNDE AND MATA VOTED NO.

ADJOURNMENT - With consensus of the Council, Mayor Lampi adjourned the meeting at 9:55 p.m.

STEVE LAMPI, MAYOR

DEVIN MONTERO, CITY CLERK

EXHIBIT A - Pg.20

RECEIVED DEC 23 2008

COPY

STATE OF MINNESOTA

DISTRICT COURT
FOURTH JUDICIAL DISTRICT
CASE TYPE: OTHER CIVIL

HENNEPIN COUNTY

Court File No.

Beverly Goerisch, Donald Goerisch,
Bernadine Simons, Sandra Simons, and
Kevin Thurs, jointly
d/b/a Elm Creek Business Park,

Plaintiffs-Petitioners

SUMMONS

v.

City of Brooklyn Park, a Minnesota
Municipal corporation

Defendant-Respondent.

The State of Minnesota to the Above-Named Defendant:

You are hereby summoned and required to serve upon plaintiff's attorney an answer to the complaint which is herewith served upon you within 20 days after service of this summons upon you, exclusive of the day of service. If you fail to do so judgment by default will be taken against you for the relief demanded in the complaint.

This action involves, affects, or brings in questions real property situated in the County of Hennepin, State of Minnesota, described as follows:

The object of this action are parcels described as follows:

Parcel one owned by Sandra B Simmons, legally described as follows:

West 144 feet of the South 300 feet of West Half of the East Half of the Southeast Quarter of the Southwest Quarter in Section 6, Township 119, Range 21;

Parcel two owned by Kevin A Thurs, legally described as follows:

Par 1

EXHIBIT H - Pg. 21

The West half of the Southeast Quarter of the Southwest Quarter, of Section 6, Township 119, Range 21, excepting road, and except the North 340 feet thereof, and except the West 144 feet of the South 300 feet of said West half of the East half of the Southeast Quarter of the Southwest Quarter; and except the South 300 feet of the East 132 feet of said West half of the East half of the Southeast Quarter of the Southwest Quarter as measured along the East and South lines thereof.

Par 2

The West 9.0 feet of the following described tract: Commencing at the Southeast corner of the West half of the East half of the Southeast Quarter of the Southwest Quarter of Section 6, Township 119, Range 21; West 132 feet parallel with South line of said tract; thence South 300 feet parallel with East line of said tract; thence East 132 feet along the South line of said tract to point of beginning, except road.

Parcel three owned by Beverly Goerisch legally described as follows:

The East Half of the West Half of the Southeast Quarter of the Southwest Quarter except the South 178 feet of the West 100 feet of the East 200 feet thereof, and except the North 400 feet thereof, Section 6, Township 119, Range 21.

Parcel four owned by Beverly Goerisch legally described as follows:

The South 178.00 feet of the West 100.00 of the East 200.00 feet of the East Half of the West half of the Southeast Quarter of the Southwest Quarter of Section 6, Township 119, Range 21.

Parcel five owned by Bernadine Simons legally described as follows:

That part of the following described tract lying East of the West 9.0 feet thereof, Commencing at the Southeast corner of the West Half of the East Half of the Southeast Quarter of the Southwest Quarter in Section 6, Township 119, Range 21, thence North 300 feet along the East line of said West Half of the East Half of the Southeast Quarter of the Southwest Quarter, thence West 132 feet parallel with South line of said tract, thence South 300 feet parallel with East line with said tract, thence East 132 feet along the south line of said tract to point of beginning, excepting road, except that part lying Southeasterly of the following described line:

Beginning at a point on a line run parallel with and distant 33 feet North of the South line of said Section 6, distant 100 feet Westerly of its intersection with a line run parallel with and distant 184 feet Westerly of Line A, described below; thence run Northeasterly to a point on said 184 foot parallel line, distant 100 feet Northerly of said intersection and there terminating Line A. Beginning at a point in the South line of said Section 6, distant 2542.9 feet East of the Southwest corner thereof; thence run Northerly at an angle of 88 degrees 52 minutes 30 seconds with said South section line (measured from East to North) for 200 feet and there terminating.

EXHIBIT H - Pg. 22

Subject to a limitation for the right of access from the above described premises to Trunk Highway No. 52, as acquired by the State in deed Doc No 832151

Dated: December 23, 2008 

Dan Biersdorf
Attorney # 8187
E. Kelly Keady
Attorney # 233729
BIERSDORF & ASSOCIATES, P.A.
33 S Sixth St., Ste 4100
Minneapolis, MN 55402
(612) 339-7242
Attorneys for Plaintiff

ACKNOWLEDGMENT

The party above-named represented by the undersigned, hereby acknowledges that sanctions may be imposed pursuant to Minn. Stat. §549.211



E. Kelly Keady

EXHIBIT H- Pg. 23

RECEIVED DEC 23 2008

STATE OF MINNESOTA

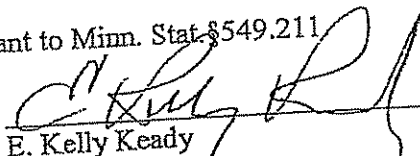
HENNEPIN COUNTY

DISTRICT COURT
FOURTH JUDICIAL DISTRICT
CASE TYPE: OTHER CIVIL

Court File No.

Beverly Goerisch, Donald Goerisch,
Bernadine Simons, Sandra Simons, and
Kevin Thurs, jointly
d/b/a Elm Creek Business Park,

COMPLAINT AND
PETITION FOR WRIT
OF MANDAMUS

Plaintiffs-Petitioners

v.

City of Brooklyn Park, a Minnesota
Municipal corporation

Defendant-Respondent.

Plaintiffs-Petitioners Beverly Goerisch, Donald Goerisch, Bernadine Simons,
Sandra Simons, and Kevin Thurs jointly d/b/a, Elm Creek Business Park for their verified
complaint and petition for writ of mandamus (the "Complaint"), states and alleges as
follows:

PARTIES

1. Plaintiffs-petitioners Beverly Goerisch, Donald Goerisch, Bernadine Simons, Sandra Simons, and Kevin Thurs are all individuals residing in Hennepin County, Minnesota and jointly doing business as Elm Creek Business Park ("Elm Creek"), a Minnesota partnership engaged in the business of developing land. Elm Creek's principal office is located at 8832 101st Avenue North, Brooklyn Park Minnesota 55445.
2. Defendant-respondent City of Brooklyn Park (the "City") is a Minnesota municipal corporation located in Hennepin County, Minnesota.

EXHIBIT H- 13.24

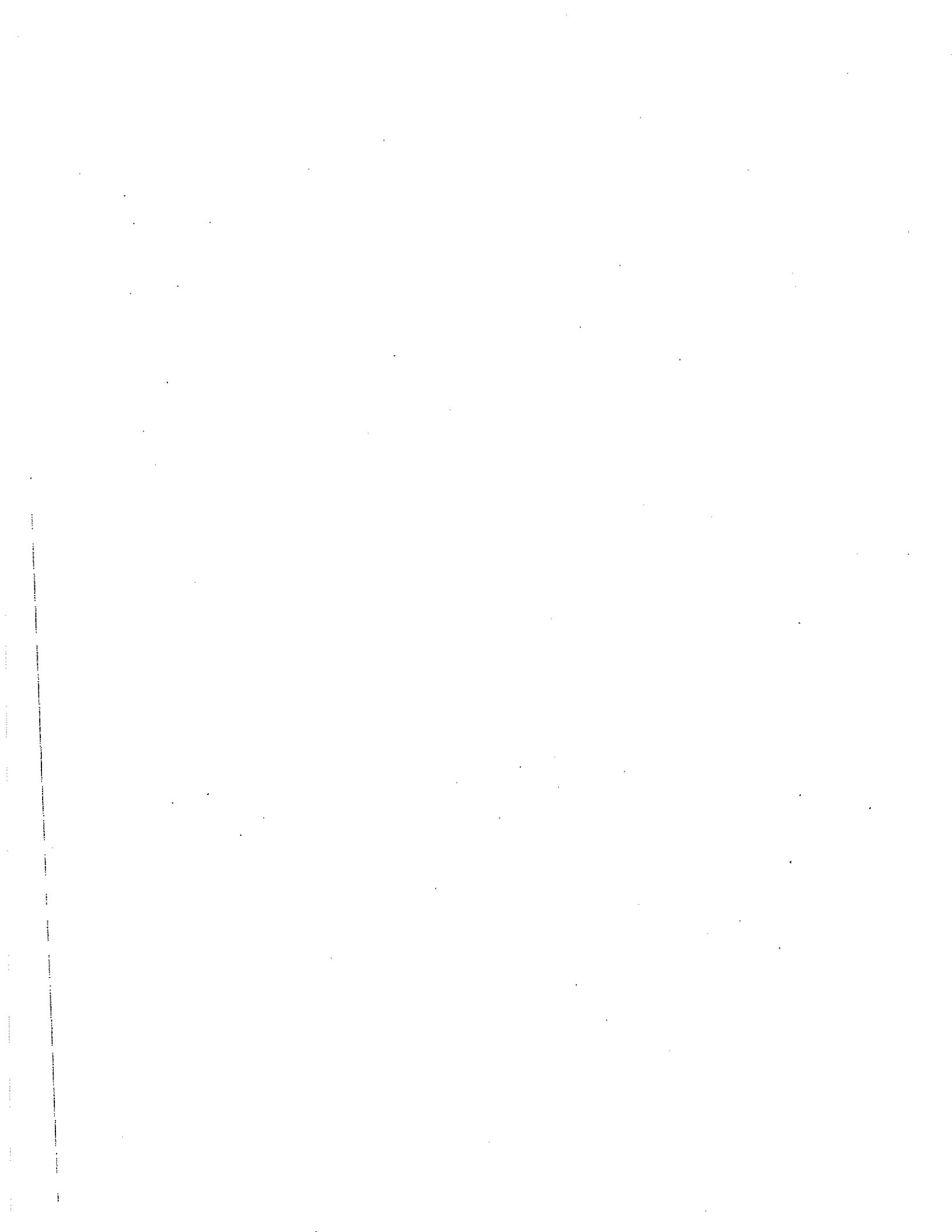

JURISDICTION AND VENUE

3. Plaintiffs-petitioners Beverly Goerisch, Donald Goerisch, Bernadine Simons, Sandra Simons, Robert Simons, and Kevin Thurs individually own the parcels in the approximately fourteen acre Elm Creek Business Park located within the City and described in Exhibit A, which is attached and incorporated into this Complaint (the "Property"). Additionally, relief is requested under Minn. Stat. Ch. 586, Mandamus and under Minn. R. Civ. P. 65, Injunctions. The presence of the City and the Subject Property in Hennepin County confer jurisdiction on this court to decide the dispute.

FACTUAL BACKGROUND

4. Plaintiffs-petitioners Beverly Goerisch, Donald Goerisch, Bernadine Simons, Sandra Simons, and Kevin Thurs are the fee owners of certain real property ("Property") located in the city of Brooklyn Park County of Hennepin, State of Minnesota, comprised of five tax parcels and legally described as follows:

Parcel one owned by Sandra B Simmons, legally described as follows:

West 144 feet of the South 300 feet of West Half of the East Half of the Southeast Quarter of the Southwest Quarter in Section 6, Township 119, Range 21;

Parcel two owned by Kevin A Thurs, legally described as follows:

Par 1

The West half of the Southeast Quarter of the Southwest Quarter, of Section 6, Township 119, Range 21, excepting road, and except the North 340 feet thereof, and except the West 144 feet of the South 300 feet of said West half of the East half of the Southeast Quarter of the Southwest Quarter; and except the South 300 feet of the East 132 feet of said West half of the East half of the Southeast Quarter of the Southwest Quarter as measured along the East and South lines thereof.

Par 2

The West 9.0 feet of the following described tract: Commencing at the Southeast corner of the West half of the East half of the Southeast Quarter of the Southwest Quarter of Section 6, Township 119, Range 21; West 132 feet parallel with South line of said tract:

EXHIBIT H - Pg. 25

thence South 300 feet parallel with East line of said tract; thence East 132 feet along the South line of said tract to point of beginning, except road.

Parcel three owned by Beverly Goerisch legally described as follows:

The East Half of the West Half of the Southeast Quarter of the Southwest Quarter except the South 178 feet of the West 100 feet of the East 200 feet thereof, and except the North 400 feet thereof, Section 6, Township 119, Range 21.

Parcel four owned by Beverly Goerisch legally described as follows:

The South 178.00 feet of the West 100.00 of the East 200.00 feet of the East Half of the West half of the Southeast Quarter of the Southwest Quarter of Section 6, Township 119, Range 21.

Parcel five owned by Bernadine Simons legally described as follows:

That part of the following described tract lying East of the West 9.0 feet thereof, Commencing at the Southeast corner of the West Half of the East Half of the Southeast Quarter of the Southwest Quarter in Section 6, Township 119, Range 21, thence North 300 feet along the East line of said West Half of the East Half of the Southeast Quarter of the Southwest Quarter, thence West 132 feet parallel with South line of said tract, thence South 300 feet parallel with East line with said tract, thence East 132 feet along the south line of said tract to point of beginning, excepting road, except that part lying Southeasterly of the following described line:

Beginning at a point on a line run parallel with and distant 33 feet North of the South line of said Section 6, distant 100 feet Westerly of its intersection with a line run parallel with and distant 184 feet Westerly of Line A, described below; thence run Northeasterly to a point on said 184 foot parallel line, distant 100 feet Northerly of said intersection and there terminating Line A. Beginning at a point in the South line of said Section 6, distant 2542.9 feet East of the Southwest corner thereof; thence run Northerly at an angle of 88 degrees 52 minutes 30 seconds with said South section line (measured from East to North) for 200 feet and there terminating.

Subject to a limitation for the right of access from the above described premises to Trunk Highway No. 52, as acquired by the State in deed Doc No 832151

5. The Property is at the Northwest corner of County Road No. 169 and 101st

Avenue North and within a half a mile of Jefferson Highway, the intersection of

Highways 610 & 169, and the new Target campus. The Property is also within minutes of

Interstate Highways 94, 494, and 35W.

EXHIBIT W - Pg. 26

6. The highest and best use of the Property is for mixed use development, office and retail or as an office park.

7. For years Elm Creek has desired to develop the Property consistent with its highest and best use.

8. On October 18, 2007 Elm Creek met with the City's Planning Director, Cindy Sherman ("Sherman"), the City's Traffic Engineer Jeff Holstein, the City's Director of Community Development Robert Schreier and Minnesota Department of Transportation's Rammankutty Cannonkuty. The purpose of the meeting was to discuss what Elm Creek could do with the Property in light of the future Highway 169 interchange planned for that area. At the meeting, Elm Creek was informed by both City and MnDOT officials that the Property would be taken for the interchange. Furthermore, Sherman made it clear to Elm Creek that the City would not let Elm Creek develop the property.

9. Numerous developers have inquired about purchasing the Property for development however they were informed by the City that the Property could not be developed because it was the future site of the Highway 169 interchange.

10. On or about July 31, 2008, Elm Creek submitted to the City its own initial concept plan for development of the Property.

11. On or about August 11, 2008, Sherman sent a letter to Elm Creek detailing comments from the staff review of Elm Creek's initial concept plan.

12. At the end of August, 2008, Elm Creek met with Sherman and informed her that they could address the City Planning staff's comments from the staff review of Elm Creek's initial concept plan.

EXHIBIT H - Pg. 27

13. On or about October 24, 2008, Elm Creek met with Sherman and addressed the City Planning staff's comments from the staff review of Elm Creek's initial concept plan. During this meeting, Sherman indicated to the Elm Creek partners that a formal application form and fee would be waived in their case and the plan would be scheduled for presentation to the planning commission at its meeting on November 12, 2008. During this meeting, Sherman requested that a copy of the presentation materials for the planning commission meeting should be given to her office by Monday, October 27, 2008.

14. On or about October 27, 2008, Elm Creek's planner, Alan Kretman ("Kretman"), delivered the requested materials referenced above to the City's planning office, however the staff refused to accept the materials.

15. On or about November 5, 2008, Sherman sent a letter to Elm Creek stating that she did not receive the requested materials but that she would "schedule the application for review on November 12, 2008 as we discussed and that staff will recommend the project not proceed based on the issues raised in my August 11, 2008 letter."

16. In response to the November 5, 2008 letter, Elm Creek met with Sherman only to discover that the City planning staff was attempting to move the review of the Elm Creek concept plan to January 2009. It was finally agreed that the review would occur at the November 12, 2008 planning commission meeting and that Elm Creek would bring their presentation materials to the meeting.

17. On November 12, 2008 the City's planning commission met to review Elm Creek's initial concept plan. The City's planning commission was asked to approve

EXHIBIT H - Pg. 28

the concept plan or deny it based upon the planning staff's recommendation for the reasons stated in Sherman's August 11, 2008 letter.

18. On November 12, 2008, Elm Creek and its representatives answered the questions and concerns raised by the planning commission including several of those raised in Sherman's August 11, 2008 letter.

19. Over Sherman's lobbying against approval of the plan, the City's planning commission voted to pass a resolution in favor of the Elm Creek development concept plan.

20. On November 24, 2008 the City Council held a public hearing on the Elm Creek development concept plan. Elm Creek brought with it the presentation materials previously discussed with Sherman including the plans which are attached and incorporated into this verified complaint and petition for writ of mandamus as Exhibit B.

21. At the November 24, 2008 City Council hearing, the City made a final decision denying Plaintiff's application.

22. On November 24, 2008 the City Council adopted "Resolution #2008-215 Resolution to Deny Concept Plan #08-123 Elm Creek Trails Business Park Located at the Northwest Corner of 101st Ave. North and Highway 169 ("the Resolution"). A copy of the Resolution is attached and incorporated into this verified complaint and petition for writ of mandamus as Exhibit C. According to the Resolution, the Elm Creek concept plan was denied for the following reasons:

1. The application is premature for the following reasons:
 - a. Roadway improvements are not in place or planned to serve the type of development proposed.
 - b. Brooklyn Park Public Utilities are not readily available to serve the site.

EXHIBIT H- pg. 29

- c. There are currently approximately 400 acres of vacant land with city services available for office development.
- d. The current market does not warrant deviating from the staging plan without a specific user identified.
- e. The Comprehensive Plan does not call for utilities to be staged into this area at this time.
- f. The Zoning of the property does not allow for a development as proposed.
- g. The civil plans have not been designed by an engineer licensed in the State of Minnesota.

23. The Resolution is not consistent with other resolutions concerning concept plans including a concept plan the City approved in the same meeting for property located within a mile of the Elm Creek property.

24. The reasons stated in the Resolution were simply a pretext for denying the Elm Creek concept plan.

COUNT I (WRIT OF MANDAMUS)

25. Plaintiffs incorporate by reference paragraphs 1 through 24 into this count.

26. This cause of action is brought pursuant to Minn. Stat. §586.01, et seq., for an order directing the City to approve the concept plan for the Elm Creek development described in Exhibit B.

COUNT II (DECLARATORY JUDGMENT)

27. Plaintiffs restate and realleges Paragraphs 1 through 26 stated herein.

28. The City's actions in failing to approve Plaintiffs' concept plan were not supported by any rational basis related to the promotion of the public health, safety and welfare.

29. Plaintiffs request that the Court declare the City's denial to be without any rational basis and that the same were arbitrary and capricious and further require the city to approve the concept plan for the Elm Creek development described in Exhibit B.

**COUNT III
TAKING**

30. Plaintiffs restate and realleges Paragraphs 1 through 29 state herein.

31. As a direct and proximate result of the City's actions, the City has deprived Plaintiffs of economic use of the Property and taken the Property for public use without paying Plaintiffs just compensation therefore, all in violation of Section 7 of Article One of the Constitution of the State of Minnesota and also in violation of the authorized purposes for which the city may exercise its powers as set forth in Minnesota Statutes Chapter 462.

32. Plaintiffs request that the Court declare the City's denial of Plaintiffs' concept plan to be a taking of Plaintiffs' property and order it to commence with eminent domain proceedings to determine just compensation for the taking.

**COUNT IV
EQUAL PROTECTION**

33. Plaintiffs restate and reallege Paragraphs 1 through 32 stated herein.

34. Pursuant to Article I Sections 2 and 16 of the Minnesota Constitution requires equality of application of the laws and that all similarly circumstanced persons be treated alike.

35. Upon information and belief, the City has allowed other similarly circumstanced property owners and developers develop their property where Plaintiffs have not been allowed to do so.

36. The City's actions in refusing to permit Plaintiffs to develop the Property, results in a denial of Plaintiffs' right to equal protection.

EXHIBIT H - pg.31

37. As a direct and proximate result of the City's actions, Plaintiffs have been damaged in an amount reasonably believed to be in excess of \$50,000.

WHEREFORE,

1. Granting Plaintiffs the declaratory relief it seeks in Count I of its Complaint.
2. Granting Plaintiffs the declaratory relief it seeks in Count II of its Complaint.
3. Granting Plaintiffs the declaratory relief it seeks in Count III of its Complaint and declare the City's denial to be a taking of Plaintiffs property and to commence with eminent domain proceedings to determine just compensation for the taking.
4. Granting judgment in favor of Plaintiffs and against Defendant for damages reasonably believe to be in excess of \$50,000 for Counts III and IV.
5. Awarding Plaintiffs their reasonable attorneys' fees incurred in pursuing this action.
6. Awarding Plaintiffs their costs and disbursements and prejudgment interest.
7. For such other and further relief as the Court deems just and equitable.

EXHIBIT H- Pg.32

Dated: December 23, 2008

Dan Biersdorf
Attorney # 8187
E. Kelly Keady
Attorney # 233729
BIERSDORF & ASSOCIATES, P.A.
33 S Sixth St., Ste 4100
Minneapolis, MN 55402
(612) 339-7242
Attorneys for Plaintiffs

ACKNOWLEDGMENT

The parties above-named represented by the undersigned, hereby acknowledges that sanctions may be imposed pursuant to Minn. Stat. §549.211.



E. Kelly Keady

EXHIBIT H- Pg. 33

STATE OF MINNESOTA

HENNEPIN COUNTY

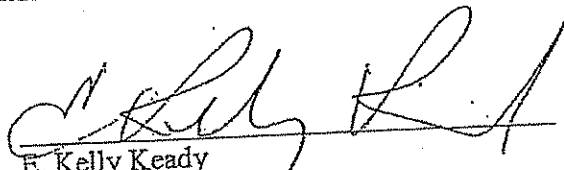
DISTRICT COURT
FOURTH JUDICIAL DISTRICT
CASE TYPE: OTHER CIVIL

Beverly Goerisch, Donald Goerisch,
Bernadine Simons, Sandra Simons, and
Kevin Thurs, jointly
d/b/a Elm Creek Business Park,

Plaintiffs-Petitioners

VERIFICATION

v.

City of Brooklyn Park, a Minnesota
Municipal corporation

Defendant-Respondent.

STATE OF MINNESOTA)

COUNTY OF HENNEPIN)

)
) ss
)

Donald Goerisch, being duly sworn, deposes and states that he is a partner in Elm Creek Business Park, and owner of two of the attached parcels as noticed on the Certificate of Title, plaintiffs-petitioner in the above-entitled matter; that he has read and fully understands the allegations of this verified complaint and petition for writ of mandamus, and that the same are true and correct, except as to those matters stated on information and belief, which matters he believes to be true and correct.

Donald Goerisch

Sworn to before me this
23rd day of December, 2008

Mark Allen Peterson
Notary

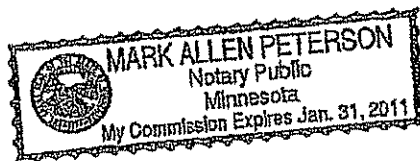

EXHIBIT H - Pg. 34

1

Certificate of Title

Certificate Number: 1003098

Document Number: 3021667

Transfer From Certificate Number: 552086

Originally registered the 3rd day of December, 1917.

Book: 51 Page: 16084

Dist. Court No.: 1710

State of Minnesota
County of Hennepin

} s.s. (06-119-21-34-0003)

REGISTRATION

This is to certify that

Sandra B. Simons, 8824 101st Avenue North, City of Brooklyn Park, County of Hennepin, State of Minnesota is now the owner of an estate in fee simple

In the following described land situated in the County of Hennepin and State of Minnesota, to wit:
West 144 feet of the South 300 feet of West Half of the East Half of the Southeast Quarter of the Southwest Quarter in Section 6, Township 119, Range 21.

Subject to the interests shown by the following memorials and to the following rights or encumbrances set forth in Minnesota statutes chapter 508, namely:

1. Liens, claims, or rights arising under the laws of the Constitution of the United States, which the statutes of this state cannot require to appear of record;
2. Any real property tax or special assessment for which a sale of the land has not been had at the date of the certificate of title;
3. Any lease for a period not exceeding three years when there is actual occupation of the premises under the lease;
4. All rights in public highways upon the land;
5. Such right of appeal or right to appeal and contest the application as is allowed by law;
6. The rights of any person in possession under deed or contract for deed from the owner of the certificate of title;
7. Any outstanding mechanics lien rights which may exist under Minnesota statutes, sections 514.01 to 514.17.

That Sandra B. Simons is 18 years of age or older, is unmarried, and is under no legal incapacity.

Document Number	Document Type	Date of Registration Month Day, Year Time	Amount (\$)	Running in Favor of
1246519	Mortgage	Nov 16, 1977	20,000.00	Conservative Mortgage Company (an IA corp) 1200 Rebooke Bldg Minneapolis, MN
1974804	Assignment of Mortgage	Nov 17, 1988		(See Midgee's Change of Name Doc No 1706700) Commercial Federal Mortgage Corporation (a NE corp) 2120 S 72nd St Omaha, NE Assigns document no. 1246519
2309261	Assignment of Mortgage	Oct 27, 1992		Source One Mortgage Services Corporation (a DE corp) 27555 Farmington Rd. Farmington Hills, MI Assigns document no. 1246519
2879818	Assignment of Mortgage	Jan 16, 1998		Chemical Mortgage Company (an OH corp) 200 Old Wilson Bridge Rd. Worthington, OH Assigns document no. 1246519 Satisfies document no. 1246519
3065776	Satisfaction of Mortgage	Sep 30, 1998		League Service Corporation City of Bloomington, State of Minnesota Assigns document no(s). 3021666.0
3108530	Assignment of Mortgage	Jan 13, 1999		PHH Mortgage Services Corporation 3000 Atrium Way, City of Mt. Laurel, State of New Jersey Assigns document no(s). 2021666.0
3108521	Assignment of Mortgage	Jan 13, 1999		North Memorial Employees Federal Credit Union City of Robbinsdale, State of Minnesota Satisfies document no(s). 3021666.0
3271725	Mortgage	Apr 13, 2000	20,000.00	
3522732	Satisfaction of Mortgage	Mar 29, 2002		

EXHIBIT H - Pg. 35

age 1

EXHIBIT

A

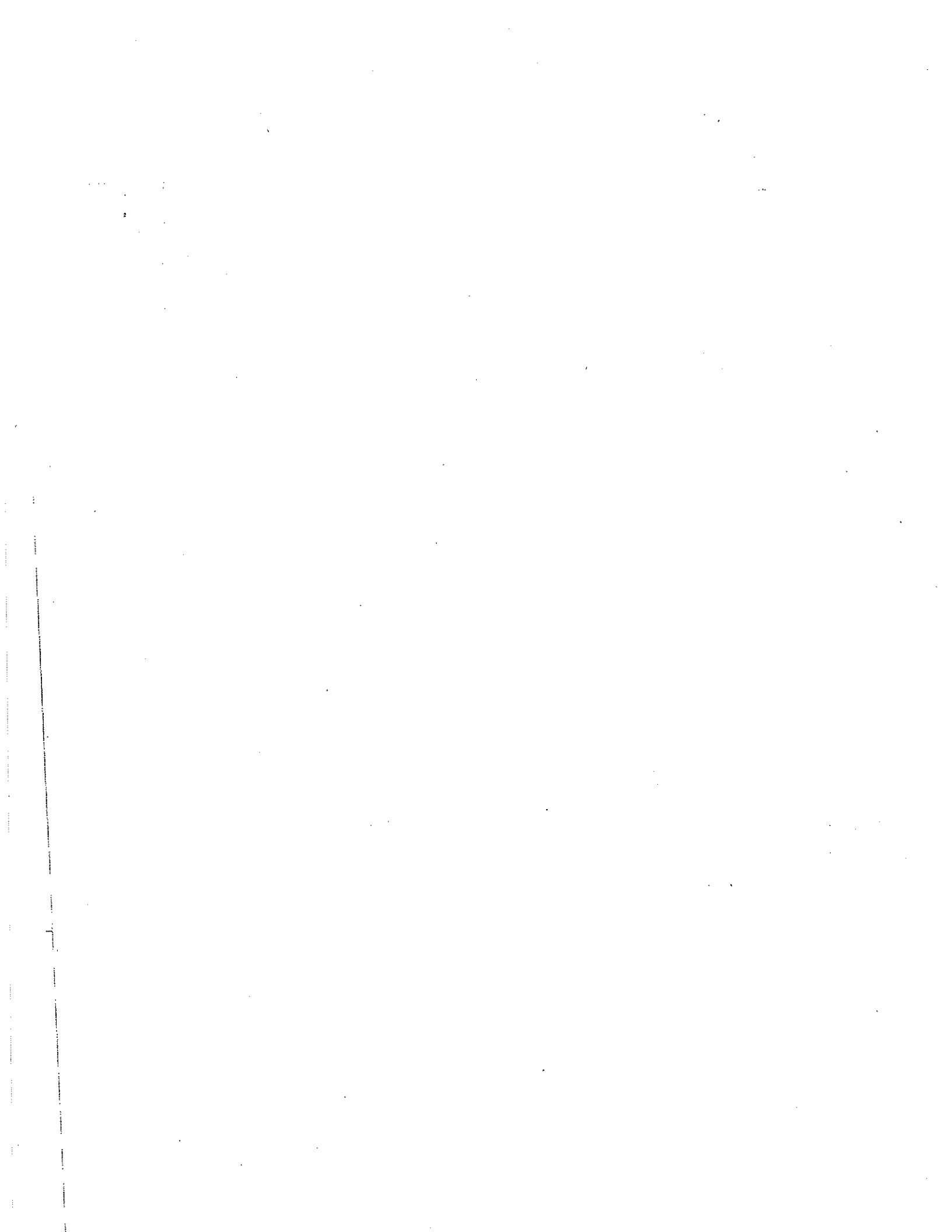

Document Number	Document Type	Date of Registration Month Day, Year Time	Amount (\$)	Running In Favor of
3523692	Mortgage	Apr 01, 2002	75,000.00	Mortgage Electronic Registration Systems, Inc., (a DE corp), P.O. Box 2026, City of Flint, State of Michigan Satisfies document no(s). 3271725.0
3553498	Satisfaction of Mortgage	Jun 03, 2002		
3813470	Mortgage	Aug 15, 2003	7,500.00	North Memorial Federal Credit Union, City of Robbinsdale, State of Minnesota
4148037	Mortgage	Aug 15, 2005	15,000.00	North Memorial Federal Credit Union, (a MN corp) City of Robbinsdale, State of Minnesota Satisfies document no(s). 3813470.0
4344816	Satisfaction of Mortgage	Jan 08, 2007		
4348748	Mortgage	Jan 17, 2007	78,000.00	JPMorgan Chase Bank, N.A., 1111 Polaris Parkway, City of Columbus, State of Ohio Satisfies document no(s). 4146037.0
4349904	Satisfaction of Mortgage	Jan 22, 2007		
4361473	Satisfaction of Mortgage	Feb 26, 2007		Satisfies document no(s). 4348748.0
4361637	Mortgage	Feb 27, 2007	196,000.00	Anchor Bank N.A., City of Blaine, State of Minnesota Anchor Bank N.A. requests notice re Foreclosure. (See Inst) re Mlge. Doc. No. 4361637
4361638	Certificate and Request for Notice	Feb 27, 2007		
4371742	Mortgage	Mar 29, 2007	40,000.00	Anchor Bank N.A., City of Blaine, State of Minnesota Anchor Bank N.A. requests notice re Foreclosure (See Inst) Re: Mortgage Doc. No. 4371742
4371743	Certificate and Request for Notice	Mar 29, 2007		
4494324	Mortgage	May 06, 2008	190,000.00	CIF Small Business Lending Corporation, (a DE corp), 640 Plaza Drive, City of Highlands Ranch, State of Colorado CIF Small Business Lending Corporation requests notice re Foreclosure. (See Inst) Re: Mlge Doc. No. 4494324
4494325	Certificate and Request for Notice	May 06, 2008		
3021566	Mortgage	May 18, 1998	51,000.00	North Memorial Employees Federal Credit Union, City of Robbinsdale, State of Minnesota

ATS indexes verified through December 11, 2008

IN WITNESS WHEREOF, I have hereunto subscribed my name and affixed the seal of my office this 18th day of May, 1998.

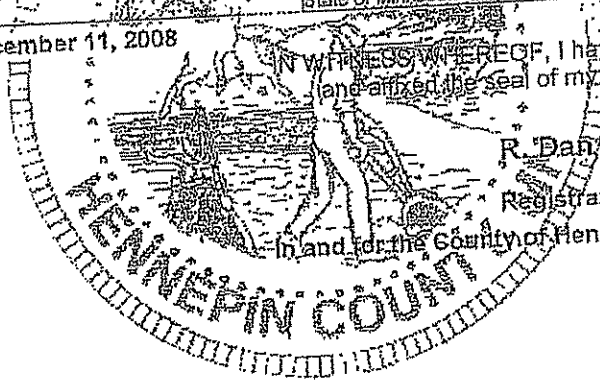

R. Dan Carlson
Registrar of Titles,

In and for the County of Hennepin and State of Minnesota.

EXHIBIT H - Pg. 36

2

Certificate of Title

Certificate Number: 859151

* See Notice of Corrections

Transfer From Certificate Number: 705992

Originally registered the 3rd day of December, 1917.

Book: 51

Page: 16084

Dist. Court No.: 1710

REGISTRATION

State of Minnesota
County of Hennepin

} s.s.

(CG-119-21-34-0007)

This is to certify that

Kevln A. Thurs, 5717 - 113th Avenue North, City of Champlin, State of Minnesota is now the owner of an estate in fee simple

In the following described land situated in the County of Hennepin and State of Minnesota, to wit:

Par 1: The West half of the Southeast quarter of the Southwest quarter of Section 6, Township 119, Range 21, excepting road, and except the North 340 feet thereof, and except the West 144 feet of the South 300 feet of said West half of the East half of the Southeast Quarter of the Southwest Quarter, and except the South 300 feet of the East 132 feet of said West half of the East half of the Southeast Quarter of the Southwest Quarter as measured along the East and South lines thereof.

Par 2: The West 9.0 feet of the following described tract, Commencing at the Southeast corner of the West half of the East half of the Southeast Quarter of the Southwest Quarter of Section 6, Township 119, Range 21; West 132 feet parallel with South line of said tract; thence South 300 feet parallel with East line of said tract; thence East 132 feet along the South line of said tract to point of beginning, except road.

Subject to the interests shown by the following memorials and to the following rights or encumbrances set forth in Minnesota statutes chapter 508, namely:

1. Liens, claims, or rights arising under the laws of the Constitution of the United States, which the statutes of this state cannot require to appear of record;
2. Any real property tax or special assessment for which any part of the land has not been paid at the date of the certificate of title;
3. Any lease for a period not exceeding three years when there is actual occupation of the premises under the lease;
4. All rights in public highways upon the land;
5. Such right of appeal or right to appear and contest the application as is allowed by law;
6. The rights of any person in possession under deed of record from the Office of the certificate of title;
7. Any outstanding mechanics lien rights which may exist under Minnesota statutes sections 514.01 to 514.17.

That Kevln A. Thurs is 18 years of age or older, is unmarried, and is under no legal incapacity.

MEMORIALS

Document Number	Document Type	Date of Registration Month Day, Year Time	Amount (\$)	Running In Favor of
2841929	Mortgage	Sep 09, 1997	51,700.00	Home Federal Savings Bank Corporation Eden Prairie, MN
829871	Easement	Nov 30, 1965		Northern States Power Company (a MN corp) Granting a perpetual easement over pt of Par 1.
1649097	Easement	Jun 05, 1985		State of Minnesota. Granting all right of access, being the right of ingress to egress from pt of Par 1 to Trunk Highway No. 169. (See Inst)
2841930	Assignment of Mortgage	Sep 09, 1997		Residential Funding Corporation Minneapolis, MN Assigns document no. 2841929
3021750	Assignment of Mortgage	Jun 08, 1998		Bankers Trust Company, as Trustee Assigns document no. 2841929
3526741	Mortgage	Apr 05, 2002	80,000.00	Wells Fargo Bank Minnesota, National Association, City of Brooklyn Park, State of Minnesota

EXHIBIT H - Pg. 37

Document Number	Document Type	Date of Registration Month Day, Year Time	Amount (\$)	Running in Favor of
2912375	Correction	Jun 02, 2003		<p>The above land description is corrected to read as follows:</p> <p>Par 1: The West half of the East half of the Southeast Quarter of the Southwest Quarter, Section 6, Township 119, Range 21, excepting road, and except the North 340 feet thereof, and except the West 144 feet of the South 300 feet of said West half of the East half of the Southeast Quarter of the Southwest Quarter; and except the South 300 feet of the East 132 feet of said West half of the East half of the Southeast Quarter of the Southwest Quarter as measured along the East and South lines thereof.</p> <p>Par 2: The West 9.0 feet of the following described tract: Commencing at the Southeast corner of the West half of the East half of the Southeast Quarter of the Southwest Quarter in Section 6, Township 119, Range 21; thence North 300 feet along the East line of said West half of the East half of the Southeast Quarter of the Southwest Quarter; thence West 132 feet parallel with South line of said tract; thence South 300 feet parallel with East line of said tract; thence East 132 feet along the South line of said tract to point of beginning, except road.</p> <p>In future certificates issued for the premises place the corrected description in the body of the certificate and omit the memorial of this correction.</p> <p>Note made July 7, 2003 (See Power of Atty Gen. No. 2526747) Satisfies document(s): 2841929.0</p>
2908426	Satisfaction of Mortgage	Jan 21, 2004		

ATS Indexes verified through December 11, 2008

IN WITNESS WHEREOF, I have hereunto subscribed my name and affixed the seal of my office this 9th day of September, 1997.

P. Dan Carlson

Registrar of Titles,

in and for the County of Hennepin and State of Minnesota.

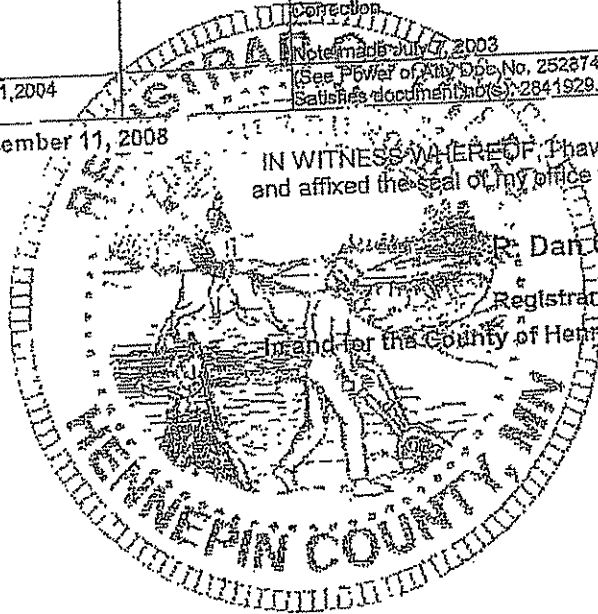

EXHIBIT H - Pg. 38

3

Certificate of Title

Certificate Number: 770376

Transfer From Certificate Number: 758349

Originally registered the 3rd day of December, 1917.

Book: 51 Page: 16084

Dist. Court No.: 1710

State of Minnesota
County of Hennepin

} s.s.

REGISTRATION

(06-119-2134-0006)

This is to certify that

Beverly A. Glor, 8832 101st Avenue North, City of Brooklyn Park, County of Hennepin, State of Minnesota is now the owner of an estate in fee simple

In the following described land situated in the County of Hennepin and State of Minnesota, to wit:

The East Half of the West Half of the Southeast Quarter of the South West Quarter except the South 178 feet of the West 100 feet of the East 200 feet thereof, and except the North 400 feet thereof, Section 6, Township 119, Range 21. Subject to the interests shown by the following memorials, and to the following rights or encumbrances set forth in Minnesota statutes chapter 508, namely:

1. Liens, claims, or rights arising under the laws of the Constitution of the United States which the statutes of this state cannot require to appear of record;
2. Any real property tax or special assessment for which a sale of the land has not been had at the date of the certificate of title;
3. Any lease for a period not exceeding three years, which title is actual occupation of the premises under the lease;
4. All rights in public highways upon the land;
5. Such right of appeal or right to appeal and contest the application as is allowed by law;
6. The rights of any person in possession under deed or contract for deed from the owner of the certificate of title;
7. Any outstanding mechanics lien rights which may exist under Minnesota statutes, sections 514.01 to 514.17.

That Beverly A. Glor is 18 years of age or older, is a person named, and is under no legal incapacity.

Document Number	Document Type	Date of Registration Month Day, Year	Amount (\$)	Running in Favor of
829728	Easement	Nov 20, 1965		Northern State Power Company (a Minn corp) Granting an easement over pt of above land (See Inst)
2168950	Mortgage	Apr 25, 1991	25,000.00	Norwest Bank Minnesota, National Association Maple Grove, MN
2649019	Mortgage	Nov 01, 1995	25,000.00	Norwest Bank Minnesota, National Association Brooklyn Park, MN
2741264	Satisfaction of Mortgage	Sep 10, 1996		Satisfies document no(s). 2168950.0
2741265	Mortgage	Sep 10, 1996	65,000.00	NFP Mortgage Corporation Coon Rapids, MN
2741266	Assignment of Mortgage	Sep 10, 1996		Norwest Mortgage, Inc. (a CA corp) Minneapolis, MN Assigns document no(s). 2741265.0 Satisfies document no(s). 2649019.0
2750530	Satisfaction of Mortgage	Oct 09, 1996		Satisfies document no(s). 2741265.0
2823190	Judgment	Jul 01, 1997	5,351.40	Scott Lawrence Glor
3225428	Mortgage	Nov 18, 1999	100,000.00	Norwest Mortgage, Inc. (a CA corp), P.O. Box 5137, City of Des Moines, State of Iowa Satisfies document no(s). 2741265.0
3230864	Satisfaction of Mortgage	Dec 03, 1999		Satisfies document no(s). 2823190.0
3599435	Satisfaction of Judgment	Sep 10, 2002		Satisfies document no(s). 2823190.0
3599436	Mortgage	Sep 10, 2002	160,000.00	TCF Mortgage Corporation City of Minneapolis, State of Minnesota Made by Donald G. Goerisch & Beverly A. Goerisch, f/k/a Beverly A. Glor
3623964	Satisfaction of Mortgage	Oct 30, 2002		Satisfies document no(s). 3225428.0

EXHIBIT

H-16-39

Document Number	Document Type	Date of Registration Month Day, Year Time	Amount (\$)	Running In Favor of
3926209	Satisfaction of Mortgage	Mar 01, 2004		Satisfies document no(s). 3599436.0
3933651	Mortgage	Mar 17, 2004	205,000.00	TCF Mortgage Corporation, (a MN corp) City of Minneapolis, State of Minnesota made by Donald G. Goerisch and Beverly A. Goerisch fka Beverly A. Glor, hus & wf.
4175718	Mortgage	Oct 18, 2005	184,000.00	TCF National Bank, City of Minneapolis, State of Minnesota Made by Donald G. Goerisch and Beverly A. Goerisch fka Beverly A. Glor
4257333	Assignment of Mortgage	May 09, 2005		Mortgage Electronic Registration Systems, Inc., (a DE corp), PO Box 2026, City of Flint, State of Michigan Assigns document no(s). 3933651.0
4530608	Mortgage	Sep 18, 2008	239,000.00	J.S. Bank, National Association, ND 4325 17th Avenue SW, City of Fargo, State of North Dakota made by Donald G Goerisch & Beverly A Goerisch, hus & wf.

ATS Indexes verified through December 11, 2008

IN WITNESS WHEREOF, I have hereunto subscribed my name
and affixed the seal of my office this 13th day of December, 1991.

R. Dan Carlson

Registrar of Titles,
In and for the County of Hennepin and State of Minnesota.

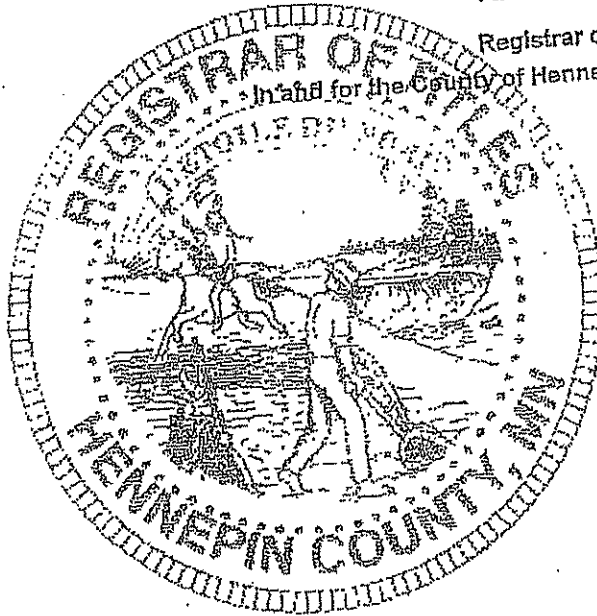

EXHIBIT A - pg. 40

4

Certificate of Title

Certificate Number: 770375

Transfer From Certificate Number: 717511

Originally registered the 3rd day of December, 1917.

Book: 51 Page: 16084

Dist. Court No.: 1710

State of Minnesota
County of Hennepin

} s.s.

REGISTRATION

This is to certify that

Beverly A. Gior, 8832 101st Avenue North, City of Brooklyn Park, County of Hennepin, State of Minnesota is now the owner of an estate in fee simple

in the following described land situated in the County of Hennepin and State of Minnesota, to wit:

The South 178.00 feet of the West 100.00 feet of the East 200.00 feet of the East Half of the West Half of the Southeast Quarter of the Southwest Quarter of Section 6, Township 41S, Range 21

Subject to the interests shown by the following memorials and to the following rights or encumbrances set forth in Minnesota statutes chapter 508, namely:

1. Liens, claims, or rights arising under the laws of the Constitution of the United States, which the statutes of this state cannot require to appear of record;
2. Any real property tax or special assessment for which a sale of the land has not been had at the date of the certificate of title;
3. Any lease for a period not exceeding three years when there is actual occupation of the premises under the lease;
4. All rights in public highways upon the land;
5. Such right of appeal or right to appeal and contest the application as is authorized by law;
6. The rights of any person in possession under deed or contract deed from the owner of the certificate of title;
7. Any outstanding mechanics lien rights which may exist under Minnesota statutes, sections 514.01 to 514.17.

That Beverly A. Gior is 18 years of age or older, sane, married and is under no legal incapacity.

ATS indexes verified through December 11, 2008

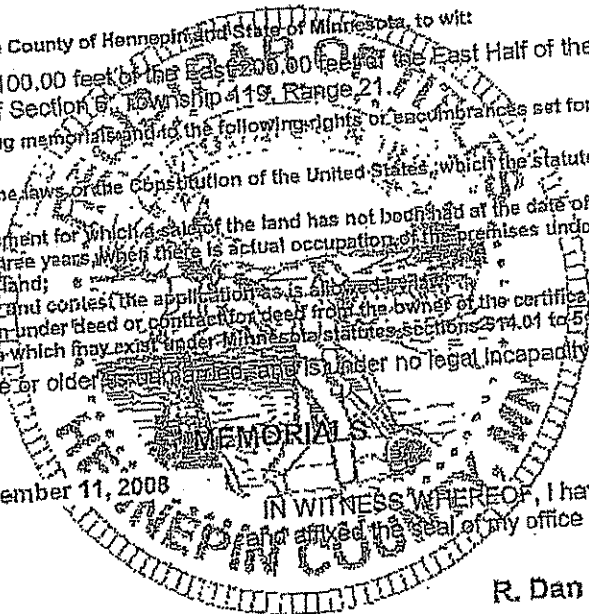

IN WITNESS WHEREOF, I have hereunto subscribed my name and affixed the seal of my office this 13th day of December, 1991.

R. Dan Carlson

Registrar of Titles,

In and for the County of Hennepin and State of Minnesota.

(06/19/21/34/0004)

EXHIBIT H-19.41

5

Certificate of Title

Certificate Number: 398532

Transfer From Certificate Number: 391174

Originally registered the 3rd day of December, 1917.

Book: 51

Page: 16084

Dist. Court No.: 1710

State of Minnesota
County of Hennepin

} s.s.

REGISTRATION

This is to certify that

Raymond A. Simons, City of Brooklyn Park, County of Hennepin, State of Minnesota, and Bernadine H. Simons, City of Brooklyn Park, County of Hennepin, State of Minnesota, as joint tenants are now the owners of an estate in fee simple

In the following described land situated in the County of Hennepin, and State of Minnesota, to wit:

That part of the following described tract lying East of the West 1/2 of the East 1/2 of the Southeast Quarter of the Southwest Quarter in Section 6, Township 119, Range 24, thence North 300 feet along the East line of said West Half of the East Half of the Southeast Quarter of the Southwest Quarter, thence West 132 feet parallel with South line of said tract, thence South 300 ft parallel with East line of said tract, thence East 132 feet along the South line of said tract to point of beginning, excepting road, except that part lying Southeastery of the following described line:
Beginning at a point on a line run parallel with and distant 33 feet North of the South line of said Section 6; distant 100 feet Westerly of its intersection with a line run parallel with and distant 83 feet Westerly of Line A, described below; thence run Northeastery to a point on said 132 foot parallel line; distant 100 feet Northerly of said intersection and there terminating Line A. Beginning at a point in the South line of said Section 6, distant 2542.9 feet East of the Southwest corner thereof; thence run Northerly at an angle of 88 degrees 52 minutes 30 seconds with said South section line (measured from East to North) for 200 feet and there terminating.

Subject to a limitation to the right of access from the above described premises to Trunk Highway No. 52, as acquired by the State in deed Doc No 832151.

Subject to the interests shown by the following memorials and the following rights of encumbrances set forth in Minnesota statutes chapter 509, namely:

1. Liens, claims, or rights arising under the laws of the Constitution of the United States which the statutes of this state cannot require to appear of record;
2. Any real property tax or special assessment for which a sale of the land has not been had at the date of the certificate of title;
3. Any lease for a period not exceeding three years, when there is actual occupation of the premises under the lease;
4. All rights in public highways upon the land;
5. Such right of appeal or right to appeal and contest the application as is allowed by law;
6. The rights of any person in possession under deed or contract for deed from the owner of the certificate of title;
7. Any outstanding mechanics lien rights which may exist under Minnesota statutes sections 514.01 to 514.17.

That Raymond A. Simons is 18 years of age or older, is married to Bernadine H. Simons, and is under no legal incapacity.
That Bernadine H. Simons is 18 years of age or older, is married to Raymond A. Simons, and is under no legal incapacity.

MEMORIALS

Document Number	Document Type	Date of Registration Month Day, Year Time	Amount (\$)	Running In Favor of
1645285	Easement	May 14, 1985		State of Minnesota, Granting all right of access to Trunk Highway No. 169 from pt of above land and a right to use part of above land for highway purposes, to expire December 1, 1989. (See Ins)

EXHIBIT H - Pg. 42

ATS Indexes verified through December 12, 2008

IN WITNESS WHEREOF, I have hereunto subscribed my name and affixed the seal of my office this 17th day of December, 1965.

Ben K. Allison

Registrar of Titles,

In and for the County of Hennepin and State of Minnesota.

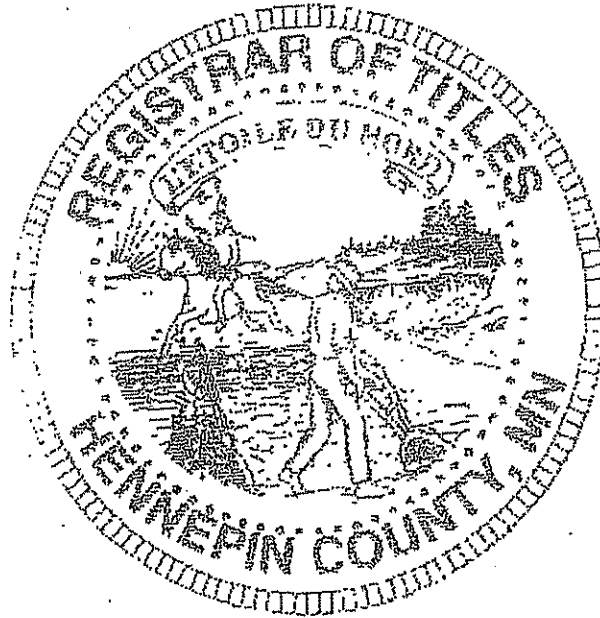

EXHIBIT H - Pg. 43

RESOLUTION #2008-215

RESOLUTION TO DENY CONCEPT PLAN #08-123
ELM CREEK TRAILS BUSINESS PARK
LOCATED AT THE NORTHWEST CORNER OF 101ST AVE. NORTH AND HIGHWAY 169
PLANNING COMMISSION FILE #08-123

WHEREAS, an application was submitted for a Concept Plan in the R-1, Urban Reserve District as described in Section 152.031 of City Code on property legally described as:

[SEE ATTACHMENT A]

WHEREAS, the property owners have submitted an application for concept review; and

WHEREAS, the property is zoned R-1, Urban Reserve district; and

WHEREAS, the property is not scheduled for public utilities in at least the next 5 years; and

WHEREAS, the applicants have indicated their desire to develop outside of the city's staging plan; and

WHEREAS, City may consider modifying the staging of utilities if there is a compelling reason to do so.

NOW, THEREFORE, BE IT RESOLVED BY THE CITY COUNCIL OF THE CITY OF BROOKLYN PARK that the concept plan for Elm Creek Trails Business Park be DENIED based on the following findings:

1. The application is premature for the following reasons:
 - a. Roadway improvements are not in place or planned to serve the type of development proposed.
 - b. Brooklyn Park Public Utilities are not readily available to serve the site.
 - c. There are currently approximately 400 acres of vacant land with city

EXHIBIT # - Pg. 44

EXHIBIT

C

- services available for office development.
- d. The current market does not warrant deviating from the staging plan without a specific user identified.
 - e. The Comprehensive Plan does not call for utilities to be staged into this area at this time.
 - f. The Zoning of the property does not allow for a development as proposed.
 - g. The civil plans have not been designed by an engineer licensed in the State of Minnesota.

The foregoing resolution was introduced by Council Member Trepanier and duly seconded by Council Member Gates.

The following voted in favor of the resolution: Gates, Lampi, Lunde, Meyer and Trepanier.

The following voted against: Gearin, Mata.

The following was absent: None.

Where upon the resolution was adopted.

ADOPTED: November 24, 2008



STEVE LAMPI, MAYOR

CERTIFICATE

STATE OF MINNESOTA
COUNTY OF HENNEPIN
CITY OF BROOKLYN PARK

I, the undersigned, being the duly qualified City Clerk of the City of Brooklyn Park, Minnesota, hereby certify that the above resolution is a true and correct copy of the resolution as adopted by the City Council of the City of Brooklyn Park on November 24 2008.

WITNESS my hand officially as such Clerk and the corporate seal of the City this 25th day of November 2008.

(SEAL)



DEVIN MONTERO, CITY CLERK

EXHIBIT H - Pg. 45

#2008-215

Attachment A

LEGAL DESCRIPTION

THAT PART OF WEST ½ OF EAST ½ OF SOUTHEAST ¼
OF SOUTHWEST ¼ LYING SOUTH OF NORTH 340 FEET
THEREOF AND LYING NORTH OF SOUTH 300 FEET
THEREOF ALSO THAT PART OF SOUTH 300 FEET OF SAID WEST ½
SECTION 06 RANGE 119 TOWNSHIP 21 (PID 06-119-21-34-0007)

AND
SOUTH 300 FEET OF EAST 123 FEET OF WEST ½ OF EAST ½ OF
SOUTHEAST ¼ OF SOUTHWEST ¼ SECTION 06 RANGE 119
TOWNSHIP 21 EXCEPT ROAD (PID 06-119-21-34-0002)

AND
WEST 144 FEET OF SOUTH 300 FEET OF WEST ½ OF EAST ½
OF SOUTHEAST ¼ OF SOUTHWEST ¼ SECTION 06 RANGE 119
TOWNSHIP 21 EXCEPT ROAD (PID 06-119-21-34-0003)

AND
THAT PART OF THE EAST ½ OF THE WEST ½ OF THE SOUTHEAST
¼ OF THE SOUTHWEST ¼ OF SECTION 6 TOWNSHIP 119 RANGE 21
LYING SOUTH OF THE NORTH 400 FEET THEREOF EXCEPT THE
SOUTH 178 FEET OF THE WEST 100 FEET (PID 06-119-21-34-0006)

EXHIBIT H - Pg. 46

#2008-215



KEY

- Blue Stain-Suave
- Blue Hydrant/Ink
- Red
- Brown Sawing
- Orange Me + Cover
- Interlocking Stone
- Light Blue - Powder

EXHIBIT H - Pg. 47

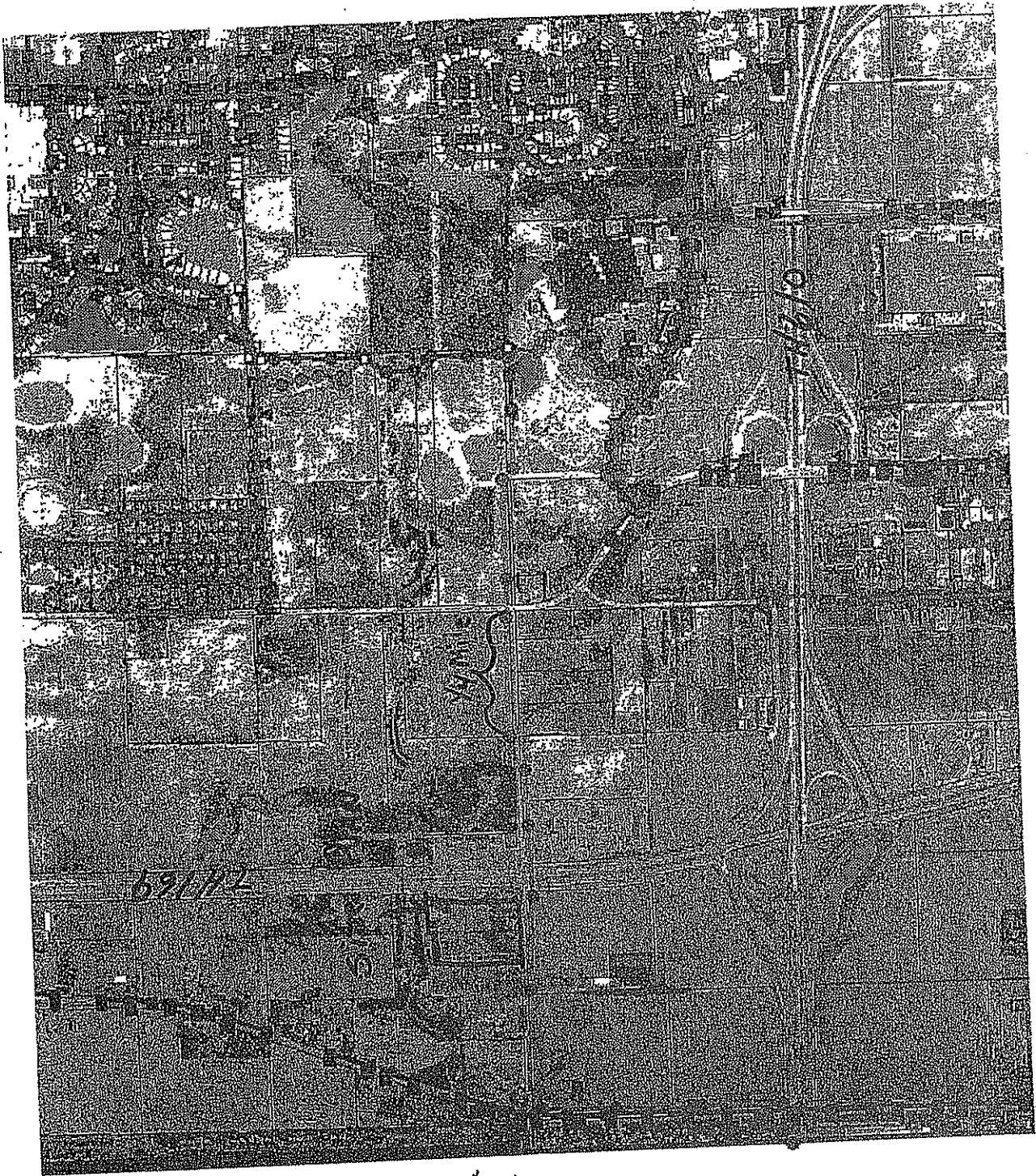

Key:
Blue: Storm Sewer
Red: Water
Orange: Sanitary Sewer
Light Blue: Ponds

EXHIBIT H- Pg. 48

