

KD  
G 2.F 295:  
2 K13

BUREAU OF CHILD RESEARCH  
LAWRENCE, KANSAS

THE KALLIKAKS  
OF  
KANSAS

REPORT OF THE COMMISSION ON PROVI-  
SION FOR THE FEEBLE-MINDED

JANUARY 1, 1919

PORTER LIBRARY 0



PUBLICATION OF THIS REPORT  
AUTHORIZED BY  
HENRY J. ALLEN, GOVERNOR  
TOPEKA

DOCUMENTS DEPARTMENT  
LEONARD H. AXE LIBRARY  
PITTSBURG STATE UNIVERSITY  
PITTSBURG, KS 66762-5889

## LETTER OF TRANSMITTAL.

*To the Governor and the Citizens of Kansas:*

The state of Kansas is justly proud of its low infant mortality rate, indicating a correspondingly high degree of social welfare. But in endeavoring to lower the infant mortality rate to its irreducible minimum for Kansas, the Division of Child Hygiene found itself confronted with the very large number of children born to feeble-minded, insane and degenerate parents, among whom the birth and death rate of infants was several times as high as among a like number of normal people. Such offspring of this degenerate group as survived infancy were found to be complicating the problems of the juvenile courts, child-placing agencies and children's institutions. Grown to adults, they were the chief source of supply of inmates for the almshouses, jails, reformatories and prisons, costing the state enormous sums of money annually to care for them and to protect society from their delinquencies.

Acting on this information, the State Board of Health and the State Board of Administration sent a joint resolution to Governor Capper requesting him to appoint a commission to study the problem of the feeble-minded in Kansas. In 1918 Governor Capper appointed the present Commission on Provision for the Feeble-minded, with instructions to investigate and report on or before January 1, 1919.

As all the work done by the commission has been volunteer, and as the time has been less than one year, an exhaustive study of the feeble-minded in Kansas has been impossible to attain. However, extensive studies of the feeble-minded have been undertaken by experts elsewhere, and since the problems of the feeble-minded are the same everywhere, the results of these investigations may very well be applied to Kansas.

The name, "The Kallikaks of Kansas," was chosen in recognition of the family history of one Martin Kallikak, a soldier of the American Revolution. This soldier was father to an illegitimate child born to a feeble-minded girl. The descendants of this feeble-minded girl, traced to the sixth generation, number nearly five hundred paupers, prostitutes, criminals and degenerates, who have cost their state one and one-half million dollars—and the end is not yet. *Each uncared-for feeble-minded boy or girl in Kansas is a possible Kallikak, and there are thousands of them.*

Special credit is due the publications of the National Committee on the Provision for the Feeble-minded and the National Committee for Mental Hygiene, also the writings and personal assistance of Mr. Joseph P. Byers and Dr. Walter E. Fernald and others who contributed in many ways to this publication.

Respectfully submitted.

LYDIA ALLEN DEVILBISS, M. D.,  
*Secretary.*

*The Kallikaks of Kansas.*

KANSAS COMMISSION ON PROVISION FOR THE  
FEEBLE-MINDED.

*President:*

G. W. GEEEN, State Board of Administration, Topeka.

*Secretary:*

DR. LYDIA ALLEN DEVILBISS, State Board of Health, Topeka.\*

*Committee on Legislation for the Feeble-minded:*

S. M. BREWSTER, Attorney-general, Topeka, *Chairman*.

DR. S. J. CRUMBINE, Secretary State Board of Health, Topeka.

LILA DAY MONROE, Attorney at Law, Topeka.

RALPH GAW, Judge of Probate Court, Topeka.

*Committee on Sociological and Economic Aspects of Feeble-minded:*

P. W. BLACKMAR, Dean of Graduate School, Kansas University, Lawrence, *Chairman*.

DR. P. C. CAVE, Superintendent School for Feeble-minded, Winfield.

W. D. BODENHOPER, Kansas University, Lawrence Kansas.

C. P. DELLINGER, Biology Department, Manual Training Normal, Pittsburg.

*Committee on Recognition and Education of Feeble-minded:*

E. A. SCHWEGLER, Professor of Education, University of Kansas, - Lawrence, *Chairman*.

DR. A. L. SKOOG, Associate Professor of Neurology, University of Kansas, Rosedale.

J. O. HALL, Superintendent of Schools, Hutchinson.

DR. B. J. ALEXANDER, Hiawatha.

H. D. RAMSEY, Superintendent of Schools, Port Scott.

*Committee on Publicity:*

CECIL HOWES, President Topeka Press Club, Topeka, *Chairman*.

MRS. H. O. GARVEY, President State Federation of Women's Clubs, Topeka.

MRS. LILLIAN MITCHNER, President State W. C. T. U., Beloit.

MRS. J. K. CODDING, President State Parent-Teacher Association, Lansing.

MISS KATE THOMEN, *Capital*, Topeka.

MISS BERTHA HEMPSTEAD, *Journal*, Topeka.

*Honorary Members of the Commission:*

DR. E. H. MULLEN, Surgeon, U. S. Public Health Service. Washington, D. C.

MR. JOSEPH P. BYERS, Executive Secretary, Committee on Provision - for the Feeble-minded, Philadelphia, Pa.

\* Deceased.

*The Kallikaks of Kansas.*

CONCLUSIONS OF THE COMMISSION ON PRO-  
VISION FOR THE FEEBLE-MINDED.

Do we know enough about the feeble-minded in Kansas  
to take care of them properly?

WE KNOW TOO MUCH TO DELAY LONGER.

Will the cost of adequate care for the feeble-  
minded in Kansas be prohibitive?

CARE WILL COST LESS THAN NEGLECT.

*The Kallikaks of Kansas.*

**What is Feeble-mindedness?**

*Feeble-minded persons* are those who never "grow up" mentally. They grow up in years and in physical development, but in their mental capacity they always remain children.

*Idiots* are those who never develop beyond infant intelligence. They are helpless and have to be cared for like little babies.

*Imbeciles* develop to the mental capacity of children from three to seven years. They can be taught to care for their own person and to avoid common dangers, and they can be trained to do simple tasks.

*Morons* have the mental capacity of children from eight to twelve years. They can be taught to do various kinds of manual labor so long as it does not require planning, reasoning or judgment.

*The morons and the border-line feeble-minded* (the very near bright) are the most dangerous of all because they are not likely to be recognized as feeble-minded. They develop all the physical desires and emotions of the adult, but having only the judgment of a child they get into all sorts of trouble for which they are blamed or punished.

*All the feeble-minded lack self-control.* They yield easily to temptation. They usually fail to earn a living when thrown wholly on their own resources. Many of them are the objects of charity. They often drift into immorality and crime. Their immoral tendencies and lack of self-control make the birth rate among them unusually high. Because of their ignorance, the sick and death rate is also high. Consequently, they complicate every social problem—child welfare, education, unemployment, poverty, and penal and charitable.

*The defect of feeble-mindedness is transmitted from parent to child.*

*The Kallikaks of Kansas.*

Feeble-minded in the United States.

We know that feeble-minded persons never become normal.

We know that feeble-minded persons complicate every social problem.

We know that feeble-mindedness is inherited and that inheritance is responsible for two-thirds of the feeble-minded population.

We know that the feeble-minded mother has a greater average number of children than the normal mother.

We know that the social evil is fed from the ranks of feeble-minded women, and that feeble-minded men and women spread venereal diseases.

We know that the feeble-minded lack in judgment and fail to resist evil influences, and that they cannot well adjust themselves to the normal life of the community.

We know that public and private organizations dealing with pauperism, vagrancy, drunkenness, family desertion and illegitimacy find the problem of feeble-mindedness complicating and greatly intensifying their constructive work of rehabilitating families.

We know that in our schools there are children called backward or retarded, that a certain percentage of these are suffering from mental deficiency, and that this greatly adds to the cost and interferes with the efficiency of the public school system.

We know that *at least* three persons in a thousand are feeble-minded (variously estimated at from three to twenty per thousand population). On the basis of the lowest estimate, there are 280,000 feeble-minded persons in the United States, 70,000 of whom are women of child-bearing age. Proper public provision has been made for less than 30,000, leaving 250,000 uncared for. Sixteen states have made no provision for the feeble-minded. *Not a single state had made adequate provision.*

We know that in every state there are feeble-minded persons in the hospitals for the insane, where they do not belong; that they are in almshouses, where they cannot be properly protected; that they are in jails, reformatories and prisons, being treated as criminals, when they are irresponsible for the crimes they commit; that there are a great many in children's institutions, from which they will in time be discharged; *that a greater number, greater than the foregoing numbers in institutions all together, are at large in their communities, where they are freely perpetuating their kind.*

## *The Kattikaks of Kansas.*

### Feeble-mindedness in Kansas,

#### WE KNOW—

That, based on the lowest conservative estimate, there are 7,500 feeble-minded persons in Kansas.

That less than one in ten of these is cared for at Winfield.

That this one in ten is taken largely from the least socially dangerous groups of the feeble-minded—the idiots and the low-grade imbeciles.

That, based on the lowest conservative estimate, there are 1,500 feeble-minded children in the public schools of Kansas where they are not receiving the type of training which will fit them to be partly self-supporting.

That the only way to *permanently stop* the increase of the feeble-minded is to transfer feeble-minded children into custodial care of the state before they reach the age of adolescence.

That the only way to *immediately stop* the abnormally high birth rate among the feeble-minded is to transfer feeble-minded men and women into colonies especially provided for their care.

### What Shall We Do About It?

*First.* Begin with the known cases of feeble-mindedness. There are enough of these obviously feeble-minded persons to keep the state busy while men of science are devising and perfecting methods of identification of high-grade and border-line cases.

*Second.* Prevent feeble-mindedness by cutting off the feeble-minded parent. All feeble-minded persons should be permanently segregated in suitable institutions or colonies, and never released from state control or supervision.

*Third.* Provide for the physical and mental examination of all school children, which will become clearing clinics for returning the normal children by competent persons. Establish special classes for backward child to the regular classes and for transferring the mentally defective child at or before the period of adolescence to the permanent custody of the state.

*Fourth.* Establish mental clinics for the examination of all persons brought before the courts charged with crime or delinquency, especially crimes against children. Extend the work of these clinics to include all persons habitually dependent upon public or private relief or charity.

*Fifth.* Enact a commitment law that shall provide for the safe and permanent custody or supervision by the state of all persons who, after competent examination and by reason of mental defect, are found to be or about to become a mental, moral or physical menace to themselves or others.

*Sixth.* Provide properly equipped institutions for all these people. They should be economically housed on farm colonies instead of being confined in elaborate and expensive buildings. They should have care and training suitable to their needs and capacity. Thus they can be protected and made happy and useful; at the same time society is protected from them and from their offspring.

*The Kallikaks of Kansas.*

**The Menace of the Feeble-minded.\***

To most people the term feeble-minded means idiot or imbecile—the distorted, pitiable -wretches that one occasionally sees in every community. These are poor, unfortunate, miserable beings, a burden to all who have to do with them. But they are the least of our troubles so far as the great social problems connected with the unfit are concerned.

In every community there are people who do not get along well. These are the great army of ne'er-do-wells who don't or can't seem to learn to do things rightly. They do things that cause them to be called "fools." As they become adults they fall into low and degrading forms of living or they become criminals.

We have known little about these people until recently because we had no accurate means of determining who they were. But now we are able to detect them. We can, even while they are still children, detect that they are lacking in that brain power which is necessary to enable them to live like normal beings. We can now, if we will, pick out these mentally deficient children and adults and care for them as their mentally irresponsible condition demands.

If a person is mentally irresponsible or feeble-minded he is never able to compete with his fellows in the struggle for existence; is never able to manage his own affairs with ordinary prudence. If he is of a phlegmatic temperament he may simply become a pauper. But if this defective person is of a different temperament and is not content simply to starve until society helps him out, he may take the matter in his own incompetent hands and either' steal or earn money by illegitimate methods, thereby becoming a criminal. If the defective is a female, one of the most natural courses for her, because she has not intellect enough to control her sex impulses and sometimes because of a perversion of this impulse, is to become a prostitute.

There is, then, *apriori*, a well-paved road for the feeble-minded person to the almshouse, to the prison, and to the brothel. Most of the mentally defective persons who are not cared for by friends follow this road and sooner or later end in these places.

Unfortunately we have not been studying the mentally deficient long enough, to have exact data, but there are many indications that somewhere from 10 to 50 percent of criminals are feeble-minded and have fallen into the criminal life because of defective mentality. It is quite probable that an equal or larger proportion of the persons in almshouses and in the ranks of prostitution are also feeble-minded. If then, in round numbers, one-fourth of these classes are replenished from the mentally defective group, *feeble-mindedness is a menace to society because it is contributing such a large percentage of these groups which are making us trouble all the time.* But this is not all.

A feeble-minded individual is always a dangerous person to have about. Many of them have lived their lives out and have been quite harm-

\* Adapted from "The Menace of the Feeble-minded," by Henry H. Goddard, Ph. D.



## *The Kallikaks of Kansas.*

less. Yet they were all the time potentially dangerous persons. The very nature of their condition—lack of self-control—is a danger. Had it happened that they had been excited, aroused or angered, they might have done the most atrocious things, bringing shame and disgrace upon other persons and causing the loss of life and property.

One has only to read the daily papers to realize that an immense amount of crime is committed by persons who are feeble-minded. Not infrequently one finds such a statement as this: "This person has been considered from childhood to be weak-minded." Even though cared for by some philanthropic person or relative who is able to take care of them, nevertheless *mentally defective persons are even then a menace, because one can never tell when some primitive instinct or impulse may lead them to do things for which they are not responsible.*

Their tendencies to pauperism and crime would seem to be sufficient grounds to justify the claim that the feeble-minded are a menace to society, yet these items pale into insignificance before the *third, which is the power of heredity of this kind of stock.* Feeble-mindedness is transmitted from father to son, from grandparents to grandchildren, with a sureness and a prolificness that is simply appalling. Traced back at least five generations, it shows no tendency of running out. Sometimes it skips a generation, coming out in the grandchildren with redoubled force. Thus certain families show an enormous number of feeble-minded, and this type of family is increasing at about twice the rate of the general population.

To-day is a day of prevention. Something must be done to prevent this stream of bad protoplasm from coming into the world and from overwhelming us with social problems. If we would cope successfully with the problem of mental defectiveness and feeble-mindedness we must put aside sentiment and deal with it in a practical manner.

## **How Do We Know The Mental Defectives?**

### RULE OF THUMB FOR GRADE-SCHOOL CHILDREN.

If a child is *one year* retarded in school he may very often catch up with his proper classes by being given some special assistance in his difficult studies.

If a child is *two years* retarded in school his chances for catching up with his proper classes are less than half what they were when he was only one year retarded. Such a child should be removed to a special class.

If a child is *three years* retarded in school, and has attended school with reasonable regularity, and is not blind or deaf and is not suffering from malnutrition, nasal obstructions, tubercular or other infections, such a child in all probability will never catch up with his proper classes. For practical purposes, this child may be regarded as mentally defective, and should be removed from the regular grade room, either to a special class, where one is provided, or to a custodial institution adapted to his training and care.

## *The Kallikaks of Kansas.*

### INTELLIGENCE TESTS.\*

A child develops mentally just as he does physically. The exact weight and physical measurements taken at regular intervals of thousands of children demonstrate beyond question that there is a definite rate of physical growth and development for the normal child, within certain defined limits of variation.

In the same manner, the normal child develops mentally at a certain rate. The mental examination of thousands of children has established this rate of mental development and its limits of variation. As a normal child of seven will be taller and weigh more than a normal child of three, so a normal child of seven will perform more difficult mental feats than a normal child of four. A child of seven who weighed only what a normal child of four should weigh would not be considered a physically normal child. So a child of seven who responded mentally in a manner ordinarily expected of a normal child of four would not be considered a mentally normal child.

The weight of a child is determined by scales, which indicate the weight in terms of pounds. The height of a child is taken with a measuring rod, which indicates the height in terms of inches. But neither the scales nor the measuring stick will indicate what it is that one is weighing and measuring.

The mental development of a child is determined by intelligence tests, which indicate the intelligence in terms of years—that is, whether the individual examined is four, seven or nine years mentally. But the intelligence tests do not indicate the *reason* why the individual measures a certain mental age level.

To the intelligence test must be added a further examination to determine whether the child is normal but slow in his mental reactions, or whether he is mentally retarded because he is blind, deaf, undernourished, poisoned by tea, coffee or cigarettes, or has been overworked or abused, or whether he is mentally defective. If mentally defective, further examination is necessary by the physician—psychiatrist, else the mentally defective child may be diagnosed as feeble-minded, when he is epileptic, an alcoholic or drug deterioration, a dementia praecox, or suffering from one of the many psychopathic states.

### DIAGNOSING HIGHER GRADES OF FEEBLE-MINDEDNESS AND BORDER-LINE DEFECTIVES.

The diagnosing of the lower grades of feeble-mindedness—the idiots and imbeciles—is a simple matter compared to detecting the high-grade moron and the border-line cases. Yet the moron differs from the imbecile quantitatively rather than qualitatively. Even in cases of very slight mental defect, some of the cardinal symptoms and conditions of imbecility are found only in lesser degree. There are generally evidences of physical inferiority, certain stigmata of degeneracy and defective muscular co-

\* For further information regarding intelligence tests, see Binet-Simon Intelligence Tests, Yerkes Point Scale, or any standard manual on the subject of measuring intelligence.

Adapted from "Diagnosing the Higher Grades of Mental Defectives," Walter E. Fernald.

### *The Kallikaks of Kansas.*

ordination. There is usually history of delayed physical development and the long continuance of untidy habits. There is frequently a history of mental defect or mental disease in the family. Unmoral or antisocial tendencies are often present. There is likely to be a history of retardation at school and poor ability on examination, with special difficulty in arithmetical and practical computations, and lack of general knowledge and information. The patient is unable to apply himself continuously in any one direction and is willing to risk severe penalties for some very small gain. His actions and conduct indicate lack of good common sense and foresight.

An accurate diagnosis of a border-line case may be made satisfactorily only after a thorough physical examination of the patient, knowledge of the family history, personal history, especially the records of infancy and early childhood, school history and records, social and moral reactions, sex habits, emotional stability, associates, interests, and the fullest inquiry as to his general information and practical knowledge.

The standard examination for diagnosing border-line cases requires ten fields of inquiry as follows: (1) Physical examination; (2) family history; (3) personal and development history; (4) school progress; (5) examination in school work; (6) practical knowledge and information; (7) social history and reactions; (8) economic efficiency; (9) moral reactions; (10) mental examination.

The various items of information are obtained from many sources. The physician makes the physical examination. The family and personal histories are obtained from relatives, the family physician, the social worker, the clergyman and others. The report of school progress is obtained from the teacher or the school records. The pedagogical examination is made on the spot with school books, paper and pencil. Practical knowledge is also tested on the spot by appropriate questions. The social history and reactions, economic efficiency and moral reactions are evolved from the general history furnished by or by direct questioning of the friends or social worker. The intelligence tests are made by the psychologist in the laboratory.

The final diagnosis of mental defect is simplified and clarified by the graphic presentation, on a one-page synopsis, of the significant positive and negative findings in each field of inquiry. This assembling and condensing of the really important data permits a visual evaluation by plus and minus signs of the evidence in each field of inquiry, and which is strikingly cumulative and convincing, either for or against a diagnosis of mental defect. Each bit of evidence is presented not only in its proper field but in relation to the evidence in other fields of inquiry.

Our legal friends have long known the potency of the plan of presenting piece after piece of evidence, each not especially important by itself, but the articulated sum of which builds up a case convincing to the most sceptical judge or jury. Our synopsis of significant findings, with its plus and minus evaluation in each field, is perhaps more nearly the equivalent of the charge of the judge to the jury, summing up the significant pros and cons culled from a great mass of experiments, where the summation of stimuli, each too slight to be perceived, nevertheless brings a maximal reaction.

## *The Kallikaks of Kansas.*

### Delinquent Defectives.\*

The term delinquent defective covers that large class of boys and girls, men and women who are feeble-minded or otherwise mentally defective plus a certain tendency to commit crime. Reformatory and prison officials recognize this class and appreciate the necessity of weeding them out from what might be called their normal population.

The fundamental idea of reformatory and penal institutions is a more or less definite period of incarceration and after-supervision tending to restore the individual to normal community life. *The whole theory breaks down when applied to the mentally defective—an individual who never can be restored to normal life.* The result is the repetition of crime, with repeated conviction and imprisonment—an ever-increasing vicious cycle. It is disastrous to the administration of reformatory and penal institutions to impose on their management the care of the mentally defective—a class of people who must be given radically different treatment—and to society who can be protected only by giving them permanent custodial care.

During the past few years a great many investigations have been made of the numbers of mental defectives existing among the inmates of institutions, especially those of the reformatory and penal group. The results of these investigations show wide variation. Because of this it is difficult to state with any degree of finality what proportion of criminals, paupers, prostitutes and delinquents are feeble-minded or otherwise mentally defective, but all reports agree that it is considerable, probably 25 percent or more.

The most conservative reports of these investigations are more than sufficient to justify all the efforts that are being made for the identification of the mental defectives. Especially this is true when made for the purpose of providing permanent custodial care for all those who, because of their mental condition, are now or who will in all human probability in the future become a menace to society.

### Mental Defectives in Kansas Almshouses.

As a class the inmates of county almshouses are not people who have had a high standard of living, and through sickness, accident or other misfortune have been rendered dependent. They are recruited from the lower strata of society. The majority of them have never had the ability or cared to accomplish much in life. With few exceptions, the inmates of almshouses are simply "down-and-out-ers," and once in the almshouse, they spend the rest of their days there.

The inmates of almshouses may be roughly divided into three classes:

1. The old and infirm.
2. Middle-aged persons not able to support themselves, through sickness and accidents.

\* Adapted from H. H. Goddard, "The Delinquent Defective."  
From investigation and report fry sociological department of Kansas University.

### *The Kallikaks of Kansas.*

3. The mentally deficient, including the insane and feeble-minded.

The popular idea concerning almshouses is that the inmates are recruited chiefly from the first two classes. Few people have realized the large numbers of mentally defective in almshouses—probably more than half the population. Only a few counties have made special provision for the mental defectives. In the majority of counties the aged and infirm, unfortunate, foreign, colored, insane, imbecilic, drunken, blind, crippled and diseased are massed together indiscriminately.

The laws of Kansas regarding the marriage of persons mentally deficient forbids the marriage of a woman under the age of forty-five years, or a man of any age except he marry a woman over forty-five years, either of whom is epileptic, imbecile, feeble-minded or afflicted with insanity. The following cases found in county almshouses show how this law has been disregarded. If all the superintendents of Kansas almshouses had kept careful records there is no doubt but that many other cases could be found where feeble-minded persons had been married:

- 1 feeble-minded woman, divorced from husband.
- 1 feeble-minded woman, husband not living.
- 3 feeble-minded men, divorced from wives.
- 1 feeble-minded man, wife not living.
- 4 feeble-minded men, separated from wives.
- 1 feeble-minded woman, married, epileptic.
- 1 feeble-minded woman, married three times.

*The inheritable nature of feeble-mindedness* and its relation to illegitimacy, crime, drunkenness and antisocial tendencies is illustrated by the following cases:

- Feeble-minded inmate, grandfather was the father of the inmate.
- Feeble-minded inmate, father was drunkard.
- Feeble-minded inmate, daughter married a negro.
- Feeble-minded inmate, had two illegitimate children and feeble-minded son.
- Feeble-minded inmate, separated from husband who is in penitentiary.
- Feeble-minded inmate, crippled, twice married, and has feeble-minded child.
- Feeble-minded inmate, separated from wife, has feeble-minded daughter.
- Feeble-minded inmate, drank whisky and killed a man.
- Feeble-minded inmate, married, has feeble-minded son in Winfield.
- Feeble-minded inmate, parents both feeble-minded.
- Feeble-minded inmate, deformed slightly, drank whisky.
- Feeble-minded inmate, has son in penitentiary for rape on feeble-minded girl.
- Feeble-minded, inmate, has child by own daughter.
- Feeble-minded inmate, white, twice married to colored man.
- Three feeble-minded inmates had illegitimate children.

One feeble-minded woman who had been in the almshouse a short time before it was visited had been an inmate twelve years previously. At that time she had given birth to an illegitimate child, which was placed in an orphan asylum in Kansas City, presumably to be adopted by some

### *The Kallikaks of Kansas.*

one not knowing of its parentage. This woman then married a soldier, by whom she had three children. The youngest, a horrible idiot, died at the age of four; the second, weak mentally and having a queer-shaped head, died at the age of two; the oldest child, now a boy of about ten, was taken away from his feeble-minded mother and given to an aunt, who is trying to reform him, it being predicted that he will eventually be sent to the penitentiary. The soldier husband deserted the woman and she returned to the almshouse to have another illegitimate child. Leaving the almshouse, this woman again married, no divorce from the first husband being obtained. It is very likely that more feeble-minded and idiotic children will be brought into the world for the county and state to support.

*The inheritableness of feeble-mindedness and the tendency of strains of mental defectiveness to run in families through several generations and evidence itself in collateral branches is shown by the following cases:*

In the Butler county almshouse: A brother and sister, both feeble-minded; the mother had died there. Father and mother were related.

In the Cowley county almshouse: A feeble-minded man whose mother had died there.

In the Douglas county almshouse: A feeble-minded man whose sister is in the Winfield institution; a feeble-minded man whose sister is in the State Insane Hospital at Topeka. There were six in this family, three boys and three girls, all weak mentally.

In the Leavenworth county almshouse: A girl deaf and dumb from birth; also her cousin, a feeble-minded woman whose nephew is in the Insane Hospital in Topeka; a feeble-minded woman, whose son was also there until his death.

In the Lyons county almshouse: A feeble-minded girl, whose father was also there.

In the Shawnee county almshouse: An insane woman, whose mother was also there.

In the Sedgwick county almshouse: A brother and sister, both feeble-minded; two husbands and wives, all four feeble-minded.

### **Mental Defectives in Court.**

The courts are primarily designed for normal persons—for those who are able to profit by experience. But every court at the present time finds itself hampered and the machinery of justice clogged by a certain large class of cases who do not profit by experience, and who come again and again before the court for similar or for increasingly serious offenses. The mental defective forms the very backbone of recidivism. These individuals who suffer from mental handicap which renders them incapable of living a normal life in the community, and which causes them to be brought repeatedly into court, deserve some special consideration.

We cannot safely proceed on the assumption that the court knows a mental defective when he sees him. The court does not know him, and,

## *The Kallikaks of Kansas*

except in certain cases of the obviously feeble-minded, degenerate or insane, the court cannot know him. But in order to deal justly and constructively with every delinquent, the court must know the intellectual powers, the character or lack of character, the ability or disability of the individual. This can be determined only after examination by a physician and psychiatrist. Yet only a very few courts in this country, and virtually none in the state of Kansas, have access to such services.

The court consequently is helpless. The court does the best it can in the matter, and according to its own best judgment the case is put on probation or sent to one of the various institutions—which one sometimes depending on the vacancies. Thus the case is disposed of for the time being, only to come up again and again for repeated offenses until the defective delinquent finally dies in prison or becomes aged and helpless and ends his days in the county almshouse.

*Table showing mental findings among 1,000 delinquents.\**

|                                   | No.   | Percent. |
|-----------------------------------|-------|----------|
| Feeble-minded . . . . .           | 231   | 23.1     |
| Psychopath . . . . .              | 104   | 10.4     |
| Psychosis . . . . .               | 58    | 5.8      |
| Epilepsy . . . . .                | 31    | 3.1      |
| Alcoholic deterioration . . . . . | 21    | 2.1      |
| Drug deterioration . . . . .      | 6     | 0.6      |
| Arteriosclerosis . . . . .        | .1    | 0.1      |
| Unclassified paranoid . . . . .   | 3     | 0.3      |
| Psychoneurosis . . . . .          | .1    | 0.1      |
| Unclassified . . . . .            | 56    | 5.6      |
| Refused examination . . . . .     | 5     | 0.5      |
| No mental examination . . . . .   | 142   | 14.2     |
| Dull normal . . . . .             | 162   | 16.2     |
| Normal . . . . .                  | 148   | 14.8     |
|                                   | 1,000 | 100.0    |

Of these 1,000 there were 456 individuals, or 45.6 percent who were suffering from abnormal mental conditions. Every one of these 456 persons is a probable candidate for ultimate custodial treatment.

### THE MENTAL DEFECTIVE IN PENAL INSTITUTIONS.

Excerpt from the report of the warden of the Kansas Penitentiary:

"For the purposes of working, disciplining, training men in night school, and for fitting them for citizenship on the outside, we make a rude classification of them here. In this institution we classify roughly 10 percent of them as insane, 10 percent of them as normal, and the rest as subnormal, including feeble-minded and all grades of mental defect. These percentages are only a rough index and vary in the institution from year to year, but they are sufficiently approximately accurate for the purpose of classifying the problem."

In the survey of one hundred cases in Massachusetts state prison, 23 percent were found to be feeble-minded and 4 percent insane. Where competent examinations have been made in various state penitentiaries about one-fourth of all the prisoners in all the institutions were found to be feeble-minded.

\* From "The Relation of Mental Defect and Disorder to Delinquency," by Dr. Victor V. Anderson, Medical Director, Medical Service of the Municipal Court, Boston.

### *The Kallikaks of Kansas.*

There is undoubtedly a larger percentage of feeble-minded and mental defectives in prisons now than heretofore, and that percentage is found to be increasing. The probation system has made it possible for the court to keep the normal man out of prison, while the subnormal man eventually goes to the institution. Thus the penal and reformatory institutions have more than their share of the mental defectives, and these managements are given the altogether impossible task of reforming, educating and making good citizens out of them.

The prisons, jails and reformatories at present are not so constructed that they can provide the necessary segregation and classification of prisoners. So the presence of mental defectives and feeble-minded retards the work of the school, cuts down the general efficiency of the shops, seriously interferes with the discipline and lowers the moral tone of the entire prison population.

A proper examination would locate and classify this large, troublesome class for whom no treatment except a permanent custodial care will be effective. The imbeciles could be safely transferred to the feeble-minded institution, the epileptics to the guarded wards of the epileptic hospital, the insane to the state hospitals for the care of the insane, and the high-grade feeble-minded and moron to prison colonies.

With this sort of arrangement it would be possible to develop a scheme of education, discipline, treatment and employment best adapted to the needs of each special class. Many of them could be made partially if not wholly self-supporting, and the courts, the prisons and society would be relieved of the drag of their presence. At the same time the defective delinquent, under the proper sort of treatment according to his special disability, is made happy and contented. From a humanitarian point of view, any other solution is untenable.



FARM COLONY FOR DELINQUENT DEFECTIVES.



## *The Kallikaks of Kansas.*

### **The Special Class in the Public Schools.\***

*The special class* is a recognition that all children of the same age do not have equal capacity for education and training. In every school district there are children who under present conditions are not receiving benefit from the money and effort spent upon them. These children include the backward, the truant and intractable, and the mentally deficient. These children have the same claim upon the state for an education as does every other child.

#### THE BENEFITS OF THE SPECIAL CLASS.

Slow and backward children are encouraged and enabled to keep up with their classes.

Intractable and truant children become interested in school work and are thereby brought under control.

Defective children are taught to do the things they can do, and the normal classroom and teacher are relieved of the drag of their presence. By cooperating with the state training school for mentally defective children, the special class can assist in preparing a large proportion of these children for useful and happy lives under custody of the state, to which they should be committed on or before adolescence.

#### ORGANIZATION OF THE SPECIAL CLASS.

Special classes have been successfully organized in more than three hundred cities and towns of the United States, and their number is constantly increasing. In the smaller cities and in rural districts the numbers of children needing special classes may be too small to warrant the expense of an extra teacher. Such districts may combine advantageously by furnishing transportation. The benefits in the resulting increased school efficiency more than offsets the increased cost;

Special classes require specially trained teachers. They must have sympathy in their work and ability in trade and manual instruction. Graduate teachers with teaching experience and specially interested in this phase of teaching can successfully take up the work after a comparatively brief course in physical and vocational training.

### **Colony Care for the Feeble-Minded.**

No manufacturer of to-day would let the by-product of his plant go to waste as society is wasting the energies of the feeble-minded, which might be called the by-product of humanity.

Left to their own devices, the feeble-minded commit crimes and are punished in jails and prisons, or sent to be reformed, when they are not reformable. They become chronic paupers, and exhaust the patience of charity and the funds of the commissioners of the poor. Unrecognized, they are committed to insane hospitals, where they occupy places needed

---

\* Adapted from "Special Classes in the Public Schools," by Joseph P. Byers.

† Adapted from "Colony Care," by Joseph P. Byers.

## *The Kallikaks of Kansas.*

for the care of the curable insane. Uncared for, they are a drag on the schools, a menace on the streets, a degenerating influence on the home and the community.

A large proportion of the feeble-minded can be made self-supporting and happy if they are supervised and their energies intelligently directed. Common business sense would demand that they be put at useful employment so as to return at least a part of what it costs to care for them. Once having learned how to perform a certain task, a feeble-minded person is delighted to do the same thing over and over again, especially if he is given an occasional smile and word of encouragement. *But someone must provide the task, direct the work, care for the product, and house, feed, clothe, guard, and encourage the feeble-minded person.*

If the prevailing and mistaken notion of elaborate and expensive institutions is discarded, the feeble-minded can be well cared for, protected and made happy at moderate cost in farm colonies. The colony herein described is a proof. Similar results are being attained in the several states experimenting with colony care instead of institutions.

The essential requirements for a colony for the care of feeble-minded are:

1. *Plenty of Land.* Preferably state reservations of forest or cut-over land, or semiarid land for irrigation projects. If state land is not available, then cheap undeveloped land or abandoned farms should be bought—land that can be made useful by clearing, draining, irrigating and otherwise being prepared for cultivation. This is work which the feeble-minded can do well. Five hundred acres should be the minimum for a colony of three hundred.

2. *Intelligent Direction of the Work.* This work should be entrusted only to those who know the feeble-minded, their capabilities and limitations, as well as what will interest and amuse them.

3. *Simple Buildings.* Buildings are preferably one story high. The feeble-minded can make brick and cement blocks and assist in the construction.

The cost of maintenance of the colony will depend largely on the opportunities for employing the "colonists." If their services are utilized in reclaiming waste land, this will materially reduce the cost of their care. If the character of the land affords opportunity for raising grains and forage for stock, fruits and vegetables for the table and the possible sale of surplus, this will further materially reduce the cost.

Under good conditions and with a population of "colonists," including a fair percentage of the higher grades of feeble-minded (imbeciles and morons), the maintenance of the colony ought to come under \$100 per year per inmate. How much under will depend on the management, the training and trainability of the inmates, the character of the soil, and the opportunities for outdoor employment.

### MENANTICO COLONY, NEW JERSEY.

A few miles west of the New Jersey coast line is a strip of land varying from five to twenty-five miles in width, most of which if properly cultivated would be a garden spot, but which at present is lying waste, covered with a scrub growth of oak and pine or undrained swamps.

## *The Kallikaks of Kansas.*

To clear this land for farming purposes is work that does not appeal to the normal man, but to the feeble-minded boy-man it is a source of joy to cut, dig and burn. It was with the idea of proving that the feeble-minded waste of humanity could recover this waste of land and make it available for farming, thus increasing its value and decreasing the cost of maintaining these wards of the state, that the first colony was begun.

Menantico colony was an experiment intended to show:

*First*, that feeble-minded men who have had training in a training school for feeble-minded can find happy and useful employment clearing rough land and preparing it for farming purposes.

*Second*, that they may be properly housed in simple but sanitary buildings, which cost much less than the usual amount spent for such purpose.

*Third*, that by giving such simplified occupation as these boy-men can understand, they may be made to contribute to their own support and the cost of maintaining them be greatly reduced.

Menantico colony was established on five hundred acres of land covered with scrub oak and pine, costing \$10 an acre. The soil under good cultivation yields good crops of sweet potatoes, berries, fruits and trucking crops, while the swamp land along the river bank offers possibilities for cranberry, huckleberry and willow culture.

The first buildings were three one-story portable houses—dining room and kitchen, dormitory and quarters for employees, and office. As soon as these were erected some of the boys were transferred to the colony and began the work of making concrete blocks for the rest of the buildings under the direction of a mason. Many of the boys were able to help in the construction work. Those not capable of such work were employed in clearing the land.

The clearing of land offered an outlet for the destructive tendencies of the boys, which are very marked when they are closely confined at school and in institutions or are permitted to roam the streets. *Instead of breaking windows, stealing and destroying property, or setting fire to haystacks and buildings, these boys are happy to cut down bushes, pull up stumps and bum the brush heaps.* What boy ever lived who is not willing to work all day to gather material for a bonfire? In two and one-half years they have cleared over one hundred acres and have raised good crops of small fruits and vegetables.

The happiness of all the boys is notable. Besides they feel that they are doing something really worth while as the results of their labors become more and more evident. They also appreciate that they are making for themselves a home. They speak of "our colony," "our field," and "my cow," or "my pig."

Up to the present time only a very small part of the feeble-minded population in any state has been housed at all, and very few of these in the proper sort of institution. The colony offers a cheap, safe and happy home for these innocents, where they will be kept from pauperism, crime and disease, and from burdening society with their numerous defective offspring.

*The Kallikaks of Kansas.*

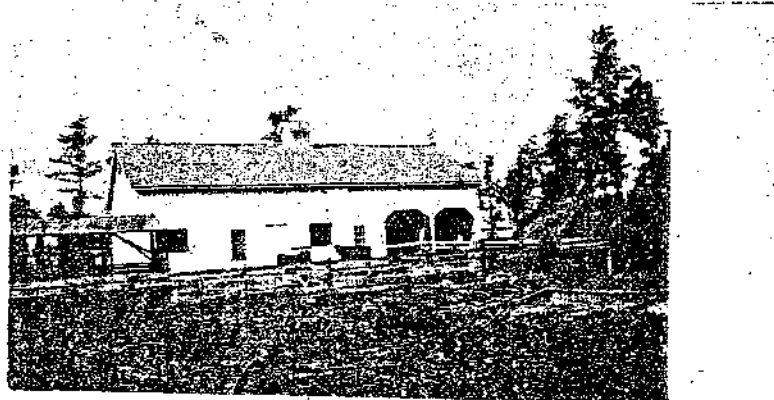

THE BARN



THE WOOD SHED

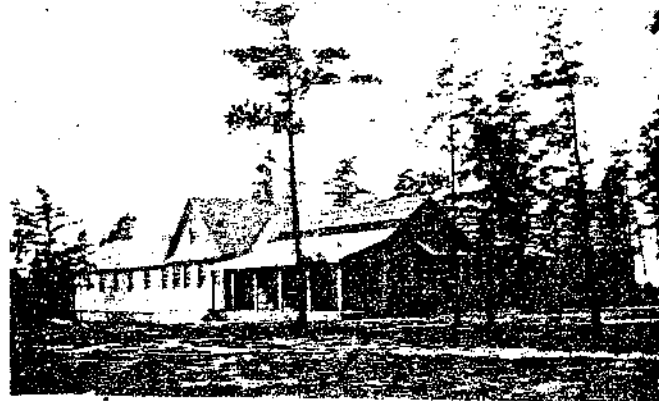

ONE OF THE BUILDINGS

VIEWS OF MENANTICO COLONY.

## *The Kallikaks of Kansas.*

### Annie's Profession.

BY MAUD A. MERRILL.

Reproduced by permission Minnesota School for Feeble-minded,  
Research Department.

It was Annie's father who began it. He had been a carpenter by trade, but failing at that by reason of his native mental incapacity, tried farming and did little better at that. Then Annie's mother died, the older sister married, and the five younger children died during an epidemic of scarlet fever. The wretched father and his half-witted daughter were left, and their house became a rendezvous for every dissolute character in the neighborhood.

Annie is as strong as an ox and does a man's work in the field. She is heavily built, with broad shoulders and large hips, strong hands and feet. Her face is broad and heavy-set and the eyes are dull and expressionless. Annie takes her recreation in drunken orgies, and for the rest it is "bizness."

Annie's first "man" was one of the drunken lot, who used to frequent her father's house. Ole thought he could "make money off'n Annie," and so he married her, deserting a former wife and child, and Annie went to earn money for Ole instead of for her father. Ole followed out his idea and brought home all sorts of dissolute characters to Annie, spending the money she earned for whiskey. Then Annie bore him a son. In the meantime Annie's old father had died and left the little farm to Annie. And when Ole could not induce her to sell the land (Annie had been warned by a shrewd neighbor that he would take the money and leave her) he deserted her. So it came about that Annie cast in her lot with Cheekke.

This business partnership was sanctioned by the law, and Annie and Cheekke had a "weddin' celebration at their place." There was the requisite keg of beer and whisky enough to inflame all of the wedding guests. A former lover of Annie's asked her to dance with him, and became so familiar that the bridegroom "got mad" and attacked the lover. A general *melee* ensued, in which one of the guests received a blow on the head that killed him. The wedding celebration ended in the arrest and subsequent conviction of three of the guests.

Annie and Cheekke took possession of the Swensk Hotel. It was a story-and-a-half frame house, most of it in ruins, but an "L" whose state of dilapidation had not progressed quite so far afforded them mean shelter. There Annie supported her bleary-eyed spouse with the money she earned from the miserable wretches who were "the guests of the hotel." There was neither lodging nor board to be had at Annie's hotel, but her profession thrived.

Four children were salvaged from the ruins of the Swensk Hotel. Two of them are feeble-minded and are inmates of an institution for the feeble-minded, a third is a normal boy, and the mental status of the fourth is not known.

Annie, an old woman at sixty, is living again in the old frame house, now almost fallen to decay, on the farm that was her father's home. One room only is habitable. This room serves Annie and Cheekke for living



## *The Kallikaks of Kansas.*

### **Poky Pete's Tale.**

BY MAUD A. MERRIL.

Reproduced by permission Minnesota School for Feeble-minded,  
Research Department.

"Yaas," he was saying, "yaas, all the children's just the same way—couldn't learn nothing at school. Me and ma wuz jus' same way, too. But," and here a spark of latent chivalry flared for a moment, "but she wuz a good deal smarter'n me. She couldn't learn neither."

Poky Pete tilted his chair to a slightly more precarious angle and proceeded with his tale. Poky, like the Russian peasant, "will talk all day if you give him a theme and a drink." I had provided the former in asking for his family history, and he had fortified himself with the latter.

"Well, as I wuz a-sayin', Lizzie—she's the one you've got down there to the feeble-minded school—she never wuz any good. She'd sleep the whole year through. You jus' couldn't trust her, neither. She'd steal anything. And she wanted to be out on the streets all night. But I jus' told her if she couldn't be in by nine p. m. she couldn't live here no more. But she would do jus' as she pleased and didn't get in soon enough, so I made her leave. She wuz too lazy for anything and couldn't learn at school, neither. She quit school as soon as she wuz fifteen. All of them are the same way—couldn't learn in school. None of 'em good for anything 'cept'n Melly. That's short for Melba. We call her that 'cause she's a music teacher. Them are hern." He waved a grimy hand towards the piano and organ, which I had noticed as we entered the little room back of his cobbler shop, which served as kitchen, dining and living room, and, it now appeared, his daughter's studio.

"Bought 'em on the installment plan," he explained in answer to the question I was about to ask.

"But there's no money in this town. Melly can't get no pupils." But where had Melly studied music? (Melly had herself assured me that she had taken lessons in Chicago.)

"Well, you see she's jus' a natural musician. She never took no lessons becuz we couldn't afford it, with the piano and organ and all."

Melly's housekeeping accomplishments were not impressive either, judged by the results in the back room. Melly was housekeeper for the family of four, as "ma" had died some ten years previous as the result of a self-induced abortion.

"Alec, he's always in trouble. He's my youngest boy. He'll steal anything he can lay his hands on. I have to sleep with my money under my pillow. But he'll steal other things and then sell 'em. He brings home and hides 'em under the barn. Says neighbor boys give 'em to him. I jus' told him to take 'em right back where he got 'em, but I heard he didn't. He went and sold 'em. He ain't no good for nothing."

"Johanna? Why, Johanna's jus' like the rest of 'em. She can't do nothin' in school. And then there's Fritz. He's the oldest boy. He's\* jus' like Lizzie—could sleep all the time. You send him to feed the horses and he'll get into the manger and go to sleep. He don't stay home no more."

### *The Kallikaks of Kansas.*

Fritz, though he exhibits many of the traits of the family, is not Poky Pete's son. He is an illegitimate son of "ma's," who had always fared with the legitimate sons and daughters without distinction until his craving for larger liberties led him to seek other quarters near the factory where he works. He has been arrested at this "boarding house" of his for indecent conduct.

"My brothers and sisters, hey? "Well, there wuz five of us, all told. Hank and Otto and Fritz and Liza and me. Fritz, he could learn pretty good in school. He came to this country about four years ago. He's married and got eight children."

This brother is a man of average ability and has a wife and eight children, all normal. One of the girls is, however, totally unreliable.

"And Hank's smart enough, only he's kinda locoed. But he's smart; he's one of these author fellers. I dunno's you'd say he wuz exactly one of 'em, but when he ain't a farmin' he sometimes writes things and sends 'em to the farm journals.

"Yaas, oh, he's married all right. He's had two wives. One of 'em died. Let's see—there wuz nine children. One of his girls got into trouble. She wuzn't right. But they made the fellow marry her. He wuz workin' on the farm then. He started right away to get a divorce, but before he'd got it she up and run off with another man. Now she's back home with two children. The other feller left her. I dunno 'bout the rest of the children.

"Otto wuz next to the oldest of us. He could learn some—nothin' extra—a little better than me. He got married, too, but his wife got a divorce, and then he went out to California, and now he's married again."

"And Lizer?" Pete had no illusions about his family. "Lizer is worse'n me. She couldn't learn nothin'. Don't know much about her now. Haven't heard from her in fifteen years.

"Yaas, she married a fellow that works in a factory in Toledo, Ohio, but he don't know much either."

Stopping only long enough to relight his pipe, Poky Pete continued with the tale of his forebears.

"The old man [his father] never came to this country. He used to be a fur worker in Germany, but he never could seem to get ahead. He'd spend money as fast as he could get it; most of it went for booze."

"Nope, he's dead; hung himself after he'd had some row in the house. The old woman's dead too. She wuzn't much on learning, but she wuz a fine housekeeper.

"The old man's folks? No, they wuzn't much either. His ma wuzn't as smart as his pa and wuz no housekeeper. We all take after her, but grandpop wuz nothin' too smart.

"No, I don't know nothing 'bout ma's folks; they never came to this country. Her name was Huldane when I married her. Her folks all live in the old country.

What's that? You don't have to be goin' yet, do you? Why I jus'—Well, come in again when you're down this way. Always glad to see yuh!"



*The Kallikaks of Kansas.*

FAMILY CHART OF POKY PETE.

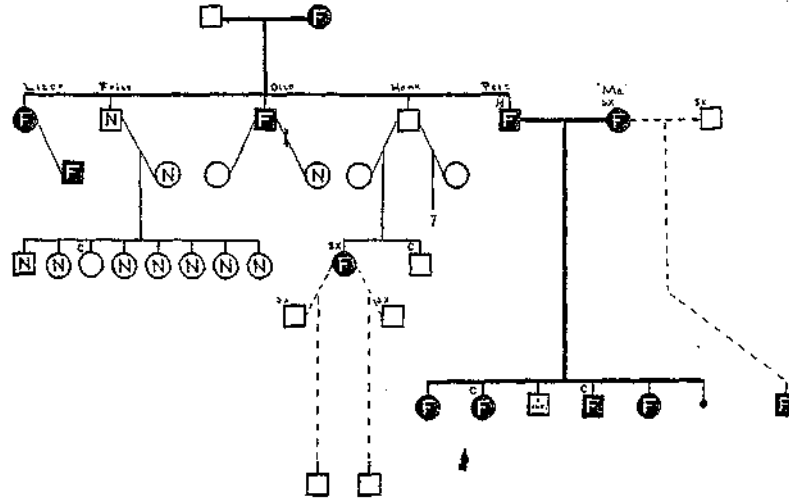

EXPLANATION OF SYMBOLS.

- |                               |   |
|-------------------------------|---|
| Square represents males.      | C means criminalistic.                    |
| Circle represents females.    | M means migrainous.                       |
| N means normal person.        | D. inf. means died in infancy.            |
| F means feeble-minded person. | The hand indicates patient in institution |
| Ex means sexually immoral.    | from which study was made.                |

The Family of Sam Simp.

By MAUD A. MERRIL.

Reproduced by permission Minnesota School for Feeble-minded,  
Research Department.

Heavy gloom overhung the usually cheerful household of the Simps. Sam's latest application to the authorities for help for his family had met with stern remonstrances. They were about to commit the whole family to an institution for the feeble-minded.

"And just hadn't he worked?" Sam inquired of the unsympathetic universe. "Most every week he'd had work." A tear traced its grimy course down his long countenance. His helpmate heaved a heavy sigh, and dumping the moth-eaten kitten from the souce pan, proceeded to fry potatoes for the evening meal. Her lugubrious countenance expressed deference for her husband's evident distress, the nature of which she grasped but vaguely. Her pink silk bosom heaved convulsively as she reflected on the darkness of existence. Sally was setting the table in unwonted silence. There were just enough dishes to go around, counting the cracked saucer which her provident soul had salvaged from the ash barrel back of Trower's store. The two youngest Simps were quarreling over the kitten in cheerful unconcern. Despite the fact that she had not yet acquired speech, Maggie could make her wants known in no uncertain terms, and she pulled vigorously at the kitten's tail, while her brother at the other end was getting rather the worst of it.

### *The Kallikaks of Kansas.*

As meal time was always rather a stormy session in the Simp household, there was no opportunity for further dwelling on their misfortunes until Sally had borne the shrieking Maggie and deposited her on the sole bed which the household possessed, and which accommodated part of the family, while the rest slept on ragged quilts on the floor. The shack boasted two rooms, one for sleeping, the other for living and eating.

It was rather a dread of the unfamiliar than any realization of the situation that depressed the spirits of Sam Simp. He was of a very confiding nature; worked hard and brought home his earnings, but his wife was no manager. They lived in luxury or starved as it chanced, and the pink silk waist, which was the joy of his wife's heart, had come out of Sam's last wages, the while they had had no bread and Billy was staying at home from school because he had no shoes. The devotion of the Simps for each other, like the quality of mercy, is unstrained. And whether there was plenty or the cupboard was bare, they were uniformly cheerful and care-free. Even such a crisis in their affairs as now confronted them could not long daunt their spirits, and they were shortly anticipating, only a bit ruefully, their new condition. And the following week Sam Simps, his wife Violet, and sons and daughters four, were committed to the Minnesota school for the feeble-minded.

Violet, the wife of Sam Simp, was one of five sons and daughters of old Len Ban and his wife, Annie. In the years following the Civil War, Len had moved his family from Ohio to Minnesota and lived in a small way on his pension. Len's mentality had never been very strong, and his wife, also mentally weak, suffered from epilepsy. There were two sons and five daughters.

Of the Ban offspring, Meg, the oldest daughter, married and moved back to Ohio. Her husband was very alcoholic, but nothing further is known of him, as he and Meg "agreed to disagree" some years ago. But Meg herself and her seven children have been carried on the records of the Associated Charities and kindred organizations ever since. Our acquaintance with the family is through the Associated Charities of Cincinnati, Ohio. Their record is one of "continued immorality, sickness and mental deficiency on the part of the mother and girls. The boys seem to have somewhat higher standards." Complaints filed with the district court alleging cruelty and neglect of the children; a commitment of one of the girls to the Salvation Army home, and later to an institution for the feeble-minded; a commitment of another to the girls' industrial home for incorrigibility, are our only glimpses of the history of Violet's sister, Meg.

Kate, another sister of Violet and Meg, married a ship's carpenter, Tammas McNam, who "works occasionally." Tammas McNam is an old man, very irascible, and often ill. He and Kate lived together as man and wife for nine or ten years before they were married. Their matrimonial career was brief and stormy. They were shortly divorced. During the years of their sojourn together Kate gave birth to two daughters. Tammas is the father of Effie, but the problem of Genevieve's paternity has never been solved. Previous to her partnership with Tammas, Kate had had a daughter, Edith, by a man with whom she lived for a time, but

The Kallikaks of Kansas.

CHART OF FAMILY OF SAM SIMP.

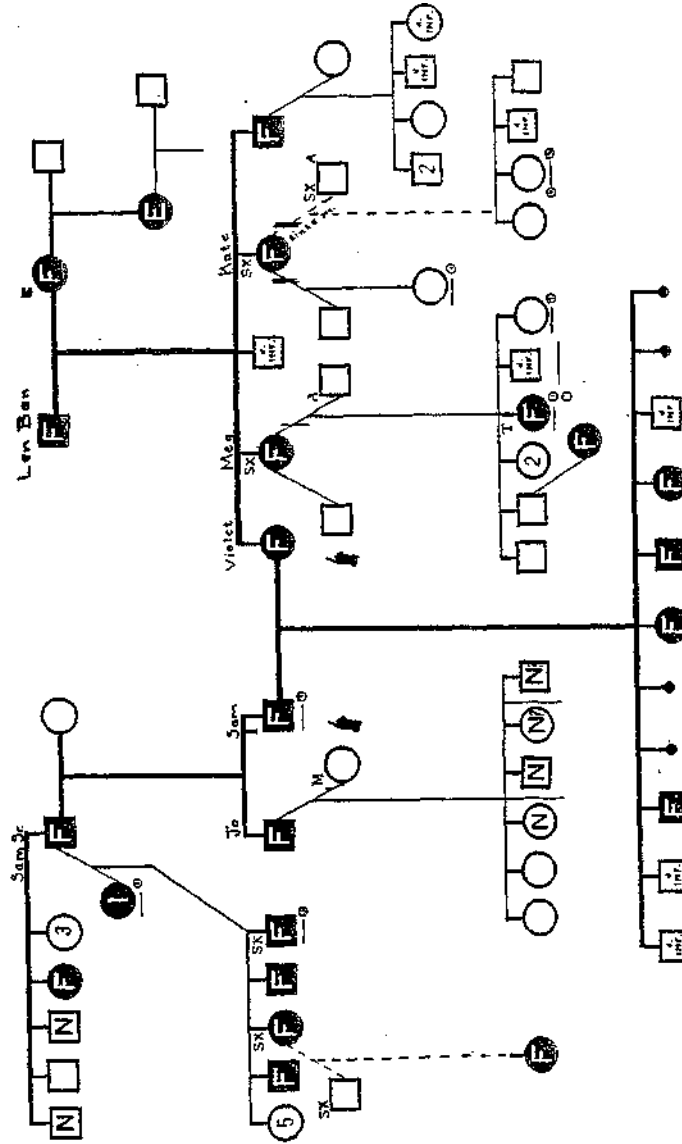

EXPLANATION OF SYMBOLS.

- |  |  |
|--|--|
| <p>Square represents males.<br/>         Circle represents females.<br/>         N means normal person.<br/>         F means feeble-minded person.<br/>         Blank square or circle, condition undetermined.<br/>         I means insane.<br/>         E means epileptic.</p> | <p>T means tuberculous.<br/>         Sx means sexually immoral.<br/>         M means migratious.<br/>         A means alcoholic.<br/>         D. inf. means died in infancy.<br/>         The hand indicates patient in institution from which study was made.</p> |
|--|--|

### *The Kallikaks of Kansas.*

whether she was married to him is an open question. The children have been cared for successively in various institutions since the home was broken up, and Kate has sought to alleviate domestic infelicity by alcoholic means. The youngest child, Effie, is still in an institution for children; Genevieve is doing well in a home; but Edith, who is past the age of jurisdiction of the juvenile court, is "keeping house for a man on E street," in a very questionable neighborhood.

One brother of Violet, Meg and Kate lived to grow up. He is a section hand. He and Violet are described by Sam Simp's brother as being "as like as two chips." The three living children of this brother and his wife, Milly, a woman of apparently normal mentality, are average children.

From their paternal progenitor the children of Sam Simp have an inheritance of much the same complexion. Sam has a brother, Jo, whose mental status is only a fraction higher than his own. Jo is night watchman in a mill, and works at odd jobs. But Jo's wife hasn't odd-job tastes. Her soul craves ostrich plumes and diamonds, and though she is a "pretty smart woman," according to the village physician, "she is extravagant and has a malicious tongue." So Jo never seems to get ahead a bit. His seven children, under the compulsory education laws, attend school. The two oldest girls are mentally slow, but the five younger ones do well in school and are considered quite up to average.

Besides Jo, Sam's only full brother, there are eleven half brothers and sisters. Sam's mother married before her marriage to the elder Simp. Her two children by a former husband have not yet been traced. After the death of Sam's mother his father married again, and had by his second wife nine children. Of these nine children four are known to be feeble-minded. Henry was sentenced to the reformatory for attempted rape. "Al" is the drudge of the household. He plods day-long at such farm work as he is capable of performing, and lives at home with his mother. Ben, another brother of the same caliber, is also a farm laborer. There are two sisters at home, Deb and Dessa. Deb is extremely nervous and erratic. She is apt to fly into spells of hysteria, and has sometimes had to be carried out of church in one of her nervous breaks. Dessa has a feeble-minded daughter whose paternity is unknown. This child was born when Dessa was about fifteen and has always been cared for at home. Two other sisters are working away from home. One clerks in a restaurant; the other, a hunchback, clerks in a dry-goods store. The others are married. Their history has not been traced. The mother of these children became insane and was confined in a state hospital.

Sam Simp's father was one of eight children. Sam, senior, was a harmless old fellow, very much like his son in disposition and character. He was the village fiddler, and used to go about to all the dances hugging an old fiddle tied with a red bandana handkerchief. There is no record of his ever having had any regular occupation. The brothers and sisters of the senior Sam have, with the exception of two, married apparently normal consorts and founded families of different standing. The sons of his sister Viola by her first husband are both well-educated men. One is an architect, the other a business man in Chicago. Viola married a second and third time, but the children of these unions have not yet been

### *The Kallikaks of Kansas.*

traced. One is known to be a physician in Chicago. Two brothers of Sam, senior, have been railroad men; their families have not been traced. A sister in the household was an idiot; she never walked or talked, but used to crawl around on the floor, and had a little low table from which she ate without having to use a chair.

And did the Simps "live happy ever after," cared for in the sanitary surroundings of their institution home? Well, Sam worked contentedly on the farm for a while; the children were happy in school and on the playground with their own kind; but not so Violet. The love of her grimy home and the longing for her consort were upon her. Eluding the utmost vigilance of the nurses, she would run away—never far, it is true—and Sam would be sent out as a decoy to lure her from her hiding place in ravine or cornfield near the institution. And Sam could always bring her back. But her unrest communicated itself to her susceptible husband. They besought the authorities of their home town to try them, again, and with such persistence did they importune that at last the very judge who had sent them to the institution promised to be responsible for them, and protests were of no avail. Sam and Violet have again taken up their abode in the dingy cottage from which they had been salvaged two years before. They have undertaken the care of one son, the others sojourning under the guardianship of the state of Minnesota until their parents see fit to take them out.

### **Kansas Legislation on the Feeble-minded.**

To permit a feeble-minded or otherwise mentally irresponsible person to have offspring is a rank injustice to the child, to the parent and to the state. Common justice and fairness demand that a feeble-minded child, having been born, be given every opportunity for the fullest possible development of his feeble talents. This is necessary to make him self-respecting and self-supporting, and to give him a small measure of happiness, which is a poor enough return for the injustice already inflicted upon him.

The state of Kansas maintains a State Home for the Feeble-minded at Winfield, whose capacity is less than 1,000. This institution was originally intended to be a training school for these unfortunate children, but it has been permitted to become more or less a custodial asylum for low-grade feeble-minded.

Session Laws 1881, chapter 35 (section 9671, G. S. 1915), established an institution for the education of idiots and imbecile children, to be denominated the "Kansas State Asylum for Idiotic and Imbecile Youth." Session Laws of 1909, chapter 233, changed the name of the institution to the "State Home for the Feeble-minded."

Admission to the Winfield institution is now on application of parent or guardian. There being no commitment law in the state, no court has the authority to commit a feeble-minded person, even though he may be a public nuisance or menace. Frequently it happens that the parent or guardian (if he be a relative) of the feeble-minded person is of such

### *The Kallikaks of Kansas.*

low-grade intelligence that he himself is proper for custodial care. The absurdity of the lack of proper commitment power by the courts immediately becomes apparent.

Section 6098, General Statutes of 1915 (amended chapter 165, Session Laws of 1917) provides for inquiry to be made when verified information in -writing is given that any resident of a county is insane, a lunatic, an idiot, an imbecile, a feeble-minded person, drug habitue, or habitual drunkard, and for any of these reasons is incapable of managing his affairs.

Section 6100, General Statutes of 1915, provides that if the jury impaneled to try the case finds that the person is insane, a lunatic, an idiot, an imbecile, a distracted person, a feeble-minded person, a drug habitue, an habitual drunkard, or one incapable of managing his affairs and in need of a guardian, the court may, if it finds that such order is necessary, appoint a guardian of the person or estate of such person, or both, as the circumstances of the case may require.

Section 6107, General Statutes of 1915, provides that every probate court by -whom any such person is committed to guardianship may make an order for the support, care and safe-keeping of such person.

In this roundabout way the guardian and the probate court may send the person to Winfield.

A larger appropriation is necessary to provide a modern training school at Winfield and to establish colonies in order to segregate properly the various grades of feeble-minded into such groups as would best facilitate their training and care. In connection with this training school a properly equipped medical and psychiatric clinic should be established to give these children the most favorable classification and treatment. If this were done, parents of mentally backward or feeble-minded children would cheerfully send their children for such special training as they require, just as parents now send their children to the State School for the Blind or Deaf. This would better the condition of the children and relieve the communities of hundreds who are now a drag in the schoolroom, who exercise a degenerating influence on the younger children with whom they are associated, and who, as they grow older, constitute a steady and constant stream of petty criminals.

Legislation is necessary to change the name of the State Home for Feeble-minded to the State Training School. Sufficient appropriation should be made to restore the original purpose of the institution.

A proper commitment law for feeble-minded should be enacted, enabling the state, when the best interests of society or the individual demand, to transfer a feeble-minded child or adult to this institution.

Such legislation and sufficient appropriation to carry it out, both as to the letter and the spirit of the law, would enable Kansas to care for the feeble-minded in a scientific manner, and in the way demanded by modern ideas for the care of these unfortunates.

We do not need to know the exact amount  
of rainfall before we put up  
an umbrella.

The wise man needs only to know  
that it is raining.